

3" Air Operated Emergency Valve

Meet the demand of today's wet-hose delivery tank trucks with the compact, high performing, Internal, Air-Operated Emergency Valves from Civacon

Our 3" Emergency Valves are specifically engineered to allow greater flexibility of tank truck design and assembly. The internal air operation cylinder allows maximum utilization of under tank chassis space while the "bellowed body" profile allows higher flow rates when unloading, and lower pressure drop when at the loading rack.

These 3" Emergency Valves are purposely designed demanding hose delivery truck applications in fleet / off-road fueling, fuel oil, lube oils and other bulk wet-hose deliver applications. Civacon, the name to depend on for innovation and reliable performance.



Features & Benefits

- 3" TTMA compact elbow design for greater flexibility of tank truck design.
- 3" Victaulic pipe connection for close proximity pipe work runs.
- Internal air cylinder allows for simpler air pipe runs - no external air cylinder or linkage to get in the way of piping.
- Pneumatic actuation can be "single acting" or "sequential" to confirm the position of the valve.
- Slotted tank sump flanges to ease installation.
- Viton seals for product compatibility.
- Air cylinder rated to -40° F to 150° F (-40° C to 66° C).
- External shear groove to TTMA specifications.
- Low pressure drop for higher flow rates.
- Light weight and robust aluminum and stainless steel construction for long service life.
- Quick strip for easy maintenance.
- Manual override feature included.
- Mesh filter screen is available as an option.

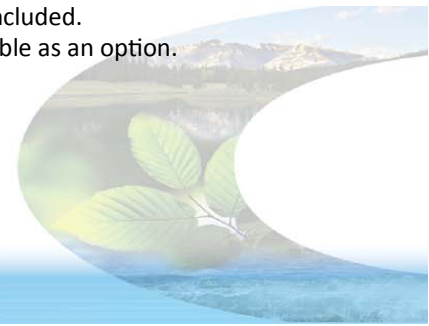

3" Air Operated Emergency Valves

Specifications

Product Numbers:
See Chart Below

Materials:
Aluminum

Dimensions:
See Diagrams

Weight:
See Diagrams

Temp. Rating:
-40° F to 150° F (-40° C to 66° C)

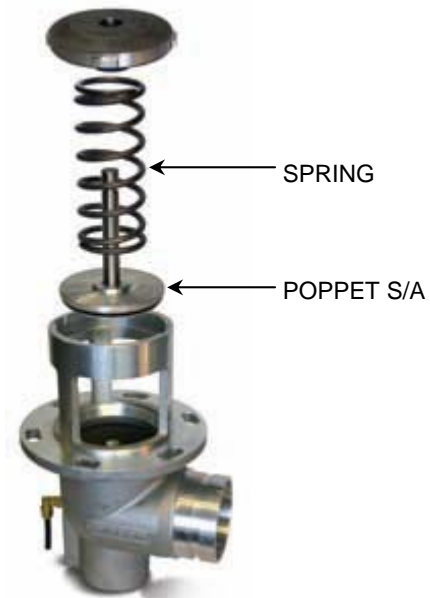

VA1050/VA1051
Weight : 7 lbs. (3.2 kg)

VA3050/VA3051
Weight : 8 lbs. (3.6 kg)

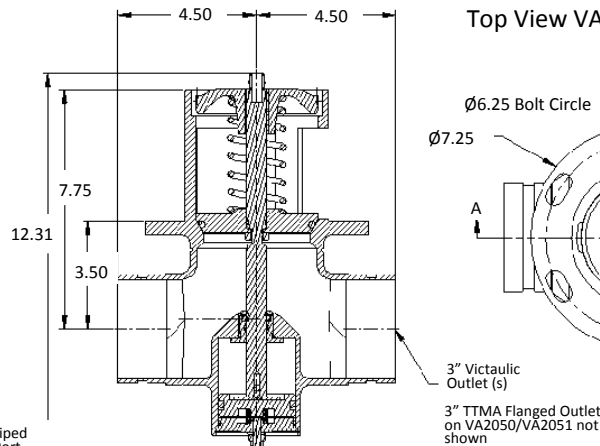
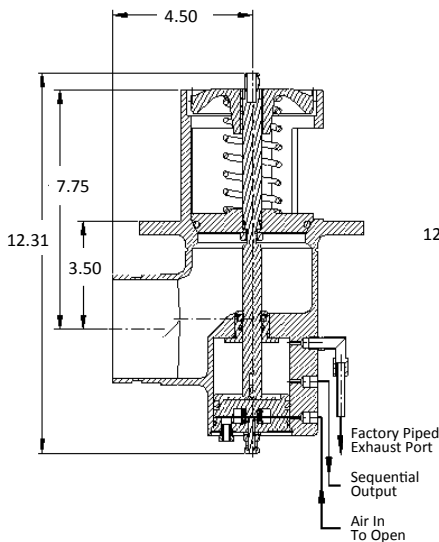

Top View VA3050/VA3051 Shown

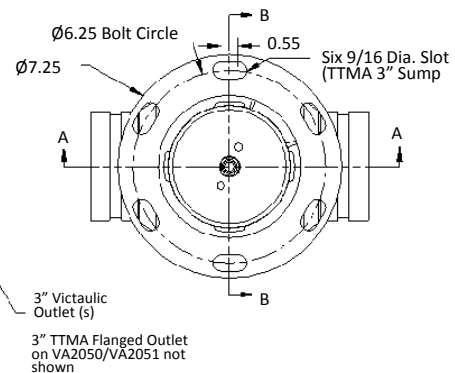

Ordering Specifications

3" Air Operated Emergency Valves

VA1050	3" Internal Valve, 90°, Victaulic Outlet, Viton GF Seat
VA1051	3" Internal Valve, 90°, Victaulic Outlet, Tef-o-Sil Seat
VA2050	3" Internal Valve, 90°, 3" TTMA Flanged Outlet, Viton GF Seat
VA2051	3" Internal Valve, 90°, 3" TTMA Flanged Outlet, Tef-o-Sil Seat
VA3050	3" Internal Valve, Tee, Victaulic Outlet Outlets, Viton GF Seat
VA3051	3" Internal Valve, Tee, Victaulic Outlet Outlets, Tef-o-Sil Seat

Replacement Parts

10347	Spring (all models)
10810M	Poppet Sub-Assembly, Viton GF Seat
11279M	Poppet Sub-Assembly, Tef-o-Sil Seat
12454	Seal Repair Kit w/Viton GF
12455	Seal Repair Kit w/Tef-o-Sil
11297	3" Screen (all models)