

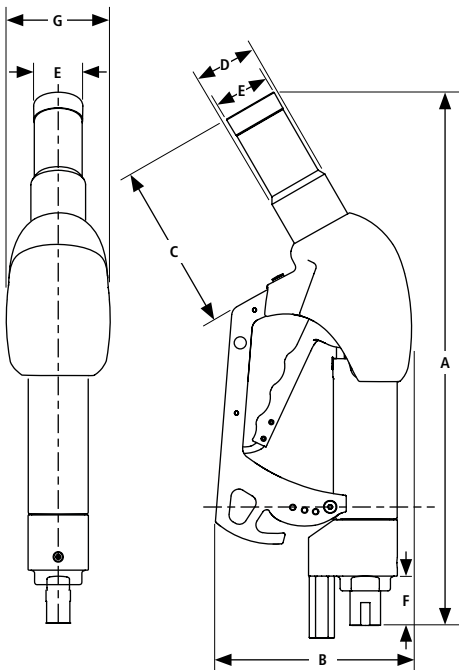

NEW

Pistol Grip Series Self-Service Nozzles (NGV1 Type 1)

OPW Pistol Grip Series Self-Service Nozzles are designed for high-flow public and private CNG fueling systems. Applications include quick-fill, self-service fueling of automobiles, light trucks, shuttle buses and vans.



Dimensions

Pistol Grip Nozzle

	in	mm
A	13.80	350.5
B	5.07	128.7
C	4.35	110.6
D	1.57	40.0
E	1.41	36.0
F	1.27	32.4
G	2.85	72.3

Materials

Body: Stainless Steel & Aluminum

Jaws: Stainless steel

Seals: Specialty polymers and elastomers for NGV applications

Inlet Filter & Magnet in hand guard are standard



Features

- ◆ **High-Flow/Fast-Fill Capability** - provides quick fueling of medium storage vehicles. Internal seals are designed for fast-fill NGV fueling.
- ◆ **Ergonomic Design** - simple squeeze and release motion ensures connection and dispensing by all users. Insulated body to protect operator's hand.
- ◆ **Directed Vent** - captures the gas vented at disconnect and directs it out of the nozzle via a 1/4" stainless steel vent which can be piped to a remote venting location or back to the upstream side of the compressor. Capturing vent gas is environmentally desirable by agencies such as the EPA and provides an added measure of safety by minimizing the amount of gas present at the filling site. It also reduces vent noise and eliminates escaped gas smell.
- ◆ **User-Friendly Lever-Action Operation** (see visuals below) - engage nozzle and receptacle with a familiar lever action. This secures nozzle jaws onto receptacle, activating a system of three internal valves that regulate fueling. The nozzle will not dispense gas until securely engaged

onto an appropriate receptacle. When fueling is complete, squeeze and release the lever to automatically stop the flow of gas into the vehicle, vent the trapped gas and release the nozzle from the receptacle. Designed for public or private self-service applications, no attendant is needed.

- ◆ **Jaw-Lock Technology** - designed specifically for the frequent coupling and uncoupling of the high-pressure gas connections of NGV fueling. Forces at the contact point are distributed over the entire surface area of the receptacle.
- ◆ **Meets NGV1 Fueling Standard** - can be used to fuel any vehicle with an NGV1 profile receptacle. (See Compatibility Matrix)
- ◆ **Individually Leak Tested and Inspected with Traceable Serial Number**

Specifications:

Min. Flow Rate: 1200 SCFM @ 3000 psid

Temperature Range: -40° F to 185° F
(-40° C to 85° C)

MAWP: 4532 psi (312.5 Bar)

Insert nozzle onto receptacle.

Squeeze-and-click to FILL.

Squeeze-and-click to VENT.



Rebuild Service and In-The-Field Repair Kits Available

Listings and Certifications



Pending Listings and Certifications

CRN



Ordering Specifications

EXAMPLES:

PG41P36 = #4 GUARD, #1 INLET HOSE CONFIGURATION; 3600 PSI (250 BAR)

PG82P30 = #8 GUARD, #2 INLET HOSE CONFIGURATION; 3000 PSI (200 BAR)

Pistol Grip Nozzle	Guard Style	Inlet Hose Configuration	Service Pressure	Connection Fill	Connection Vent	Approximate Weight
PG	3	1	P36	3/4-16 UNF-2A, -8 37° JIC	-4 37° JIC	4.6 lbs.
	4	1	P36	3/4-16 UNF-2A, -8 37° JIC	-4 37° JIC	4.6 lbs.
	8	1	P36	3/4-16 UNF-2A, -8 37° JIC	-4 37° JIC	4.6 lbs.
	3	2	P36	9/16-18 UNF-2A, -6 37° JIC	-4 37° JIC	4.6 lbs.
	4	2	P36	9/16-18 UNF-2A, -6 37° JIC	-4 37° JIC	4.6 lbs.
	8	2	P36	9/16-18 UNF-2A, -6 37° JIC	-4 37° JIC	4.6 lbs.
PG	3	1	P30	3/4-16 UNF-2A, -8 37° JIC	-4 37° JIC	4.6 lbs.
	4	1	P30	3/4-16 UNF-2A, -8 37° JIC	-4 37° JIC	4.6 lbs.
	8	1	P30	3/4-16 UNF-2A, -8 37° JIC	-4 37° JIC	4.6 lbs.
	3	2	P30	9/16-18 UNF-2A, -6 37° JIC	-4 37° JIC	4.6 lbs.
	4	2	P30	9/16-18 UNF-2A, -6 37° JIC	-4 37° JIC	4.6 lbs.
	8	2	P30	9/16-18 UNF-2A, -6 37° JIC	-4 37° JIC	4.6 lbs.

*NOTE: Inlet filter and magnet in hand guard are standard.

Guard Style



Inlet Hose Adaptors

- Compatible with most CNG hose configurations in USA using -8 fill and -4 vent
- Compatible with most hose configurations using -6 fill and -4 vent

Parts

	P36 Yellow	P30 Blue
#3 Guard Assembly	210072	210240
#4 Guard Assembly	210055	210239
#8 Guard Assembly	210073	210242
Protective Sleeve	209018	209801
Top Cover	209802	209803
Inlet Filter	001065	

Dispenser Mount

211290 Stainless steel, II gage compatible with 3, 4 and 8 guards shown above

