



CNG Type-2 Fueling System

The OPW CleanEnergy CNG 3-Way Valve and Type-2 Nozzle features the latest in industrial and commercial fueling innovations. It is a fueling system that bridges the gap between convenience and comfort without sacrificing flow or reliability. Ergonomically designed to be easy to use and prevent unnecessary wear and tear during the fueling process.

NT2A Series Fast-Fill/ Fleet-Fill Nozzles (NGV1 & ISO14469 Type-2 or 3)

OPW NT2A Series Fast-Fill/Fleet-Fill Nozzles are designed for high-flow CNG-fueling systems. Applications include quick-fill fueling of automobiles, light trucks, shuttle buses, vans and time-fill or overnight fleet fueling.

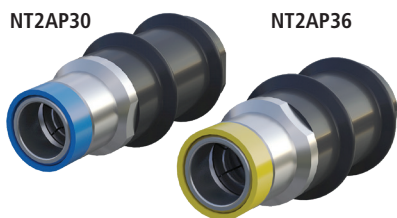

Product #	Inlet Thread Size	Color	Service Pressure
NT2AP30	SAE - 6, 9/16" - 18 UNF	Blue	NGV1 P30 ISO14469 B200 3000 psi (200 bar)
NT2AP36	SAE - 6, 9/16" - 18 UNF	Yellow	NGV1 P36 ISO14469 B250 3600 psi (250 bar)

Materials



High-Pressure 3-Way Valve

Cost Effective - OPW Leads the Way in CNG-Fueling Innovation, Design and Construction.

Inlet Tubing Offset – designed to eliminate mis-connections on OPW CNG Hose Sets.

Features

- ◆ **Hose-Connection Options** - Time-Fill Applications - 4/4 Sized Hose (1/4" Inlet and 1/4" Vent). Fast-Fill Applications - 4/6 Sized Hose (3/8" Inlet and 1/4" Vent)
- ◆ **Ergonomic Grip** - Provides user comfort and control while protecting vehicles from dents and scratches during fueling.
- ◆ **NT2A Series Nozzle** - Features a field-serviceable internal filter to capture gas-borne debris commonly found in CNG-Fueling systems.

Listings and Certifications



NGV1 ISO14469

NEW

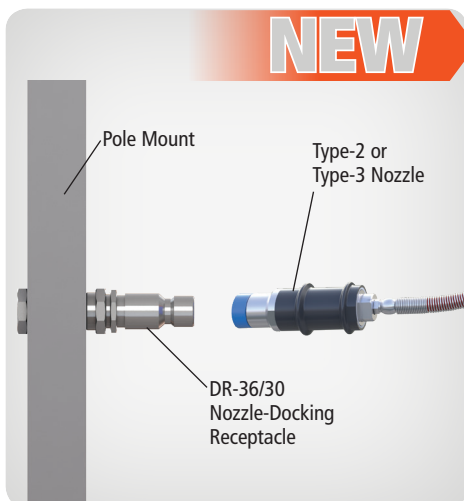

DR-36/30 Nozzle-Docking Receptacle

This is a Nozzle-Docking receptacle to be used ONLY for Type-2 and Type-3 nozzle-mounting purposes. There are no working internals, therefore it may only be used as a docking-storage device. **NOTE:** It shall not be used to dock a Type-1 nozzle.

Nozzle Types

- Type 1** - Nozzle with an integrated vent-valve system. This vent valve is controlled by single-lever operation which will safely vent the gas trapped between the receptacle check valve and the nozzle inlet valve. After the venting process, the nozzle will disconnect from the vehicle's receptacle.
- Type 2** - The vent-valve operating mechanism is external to the nozzle. Venting is required prior to disconnection of this type of nozzle.
- Type 3** - The fueling hose is automatically depressurized below 50psi (3.4Bar) at dispenser shutdown. The nozzle will vent low-pressure gas between the receptacle check valve and the nozzle inlet valve.

NOTE: This device shall not be installed on a vehicle nor be connected to a pressurized source of any type.

Ordering Specifications

Product #	Description
DR-36/30	Nozzle-Docking Receptacle

CNG Type-2 Fueling System



Ordering Specifications

Product #	Description	Connection		Approx. Weight	Service Pressure
		Fill	Vent		
3WV-44PFG	3-way valve, cover and outlet tubing and 3/4" extender	4-SAE-AN	4-SAE-AN	1.4 lb. (.63 kg)	up to 5,000 psi / 345 bar
3WV-44AP30-NT	3-way valve, cover, outlet tubing and 3/4" extender and NT2AP30	4-SAE-AN	4-SAE-AN	2.74 lb. (1.24 kg)	3,000 psi / 207 bar
3WV-44AP36-NT	3-way valve, cover, outlet tubing and 3/4" extender and NT2AP36	4-SAE-AN	4-SAE-AN	2.74 lb. (1.24 kg)	3,600 psi / 250 bar
3WV-46PFG	3-way valve, cover, outlet tubing and 3/4" extender	8-SAE-AN	4-SAE-AN	1.4 lb. (.63 kg)	up to 5,000 psi / 345 bar
3WV-46AP30-NT	3-way valve, cover, outlet tubing and 3/4" extender and NT2AP30	8-SAE-AN	4-SAE-AN	2.74 lb. (1.24 kg)	3,000 psi / 207 bar
3WV-46AP36-NT	3-way valve, cover, outlet tubing and 3/4" extender and NT2AP36	8-SAE-AN	4-SAE-AN	2.74 lb. (1.24 kg)	3,600 psi / 250 bar

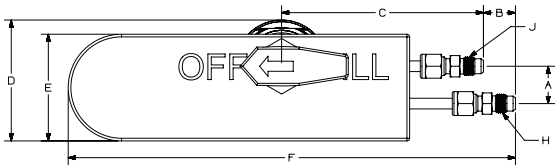

Dimensions

	3WV-44AP30/6-NT		3WV-46AP30/36-NT		3WV-44PFG		3WV-46PFG	
	in	mm	in	mm	in	mm	in	mm
A	.875	22.22	.875	22.2	.875	22.22	.875	22.22
B	.75	19.05	.75	19.05	.75	19.05	.75	19.05
C	4.73	120.14	4.73	120.14	4.73	120.14	4.73	120.14
D	2.83	71.95	2.83	71.95				
E	2.5	63.5	2.5	63.5	2.5	63.5	2.5	63.5
F	10.48	266.19	10.48	266.19	10.48	266.19	10.48	266.19
G	8.69	220.76	8.69	220.76	3.79	96.16	3.79	96.16
H	#4 SAE		#8 SAE		#4 SAE		#8 SAE	
J	#4 SAE		#4 SAE		#4 SAE		#4 SAE	

CT1000 Series Self-Service Nozzles (NGV1 & ISO14469 Type-1)

OPW CT1000 Series Self-Service Nozzles are designed for high-flow public and private CNG-fueling systems. Applications include quick-fill, self-service fueling of automobiles, light trucks, shuttle buses and vans.

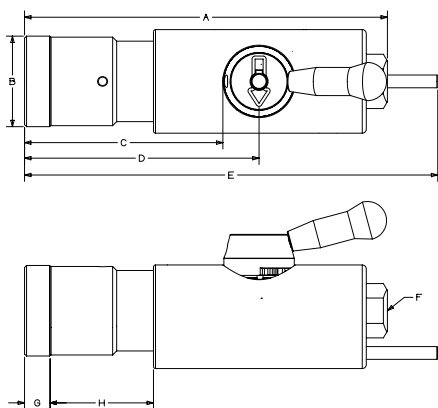

Dimensions

	CT1000P36S / CT1000LS	
	in	mm
A	7.10	180.4
B	1.77	45.0
C	3.88	98.6
D	4.59	116.6
E	8.08	205.4
F	Straight Thread O-ring Boss Port SAE-6 J1926 (9/16" - 18 UNF-2B)	
G	.50	12.7
H	2.02	51.4

Materials

Body: Brass

Jaws: Stainless steel

Seals: Specialty polymers and elastomers for NGV applications

CT1000P36S
Coupling End



CT1000P36S
Hose Connection End

Features

- ◆ **High-Flow/Fast-Fill Capability** - provides quick fueling of medium-storage vehicles. Internal seals are designed for fast-fill NGV fueling.
- ◆ **User-Friendly Single-Action Operation** - engage nozzle and receptacle with a 180° rotation of the handle. This secures nozzle jaws onto receptacle, activating a system of three internal valves that regulate fueling. The nozzle will not dispense gas until securely engaged onto an appropriate receptacle. When fueling is complete, rotate the handle to the disconnect position to automatically stop the flow of gas into the vehicle, vent the trapped gas and release the nozzle from the receptacle. The 1000 Series nozzles connect directly to the hose, with no need for a three-way valve. Designed for public or private self-service applications, no attendant is needed.
- ◆ **Directed Vent (CT1000)** - captures the gas vented at disconnect and directs it out of the nozzle via a 1/4" stainless-steel vent tube (requires -4 compression adaptor), which can be piped to a remote venting location or back to the upstream side of the compressor. Capturing vent gas is environmentally desirable by agencies such as the EPA and provides an added measure of safety by minimizing the amount of gas present at the filling site. It also reduces vent noise and eliminates escaped gas smell.
- ◆ **Jaw-Lock Technology** - designed specifically for the frequent coupling and uncoupling of the high-pressure gas connections of NGV fueling. Forces at the contact point are distributed over the entire surface area of the receptacle.
- ◆ **Ergonomic Design** - one simple and convenient motion ensures connection and dispensing by all users. Insulated jacket protects operator's hand.
- ◆ **Durable Construction** - heavy-duty brass and stainless-steel construction provides corrosion resistance in harsh refueling environments.
- ◆ **Tamper Resistant** - specially designed cam system actuates the front and rear module. Tampering with the valve results in immediate dispensing shutoff.
- ◆ **Individually Leak Tested and Inspected with Traceable Serial Number**

Specifications:

Min. Flow Rate: 1200 SCFM @ 3000 psid

Temperature Range: -40° F to 185° F
(-40° C to 85° C)

Cv: 0.84

MAWP: 4532 psi (312.5 Bar)

Ordering Specifications

Product #	Inlet Thread Size	Vent Tube Size OD		Service Pressure	Weight	
CT1000LS	SAE - 6, 9/16" - 18 UNF	1/4"	NGV1P30 ISO14469 B200	3000 psi 207 bar	3.66 lbs.	1.66 kg
CT1000P36S	SAE - 6, 9/16" - 18 UNF	1/4"	NGV1P36 ISO14469 B250	3600 psi 250 bar	3.65 lbs.	1.65 kg

Listings and Certifications



NGV1
ISO14469

CRN

See page 23 for Canadian Registration Number