

# GRP Underground Containment Systems

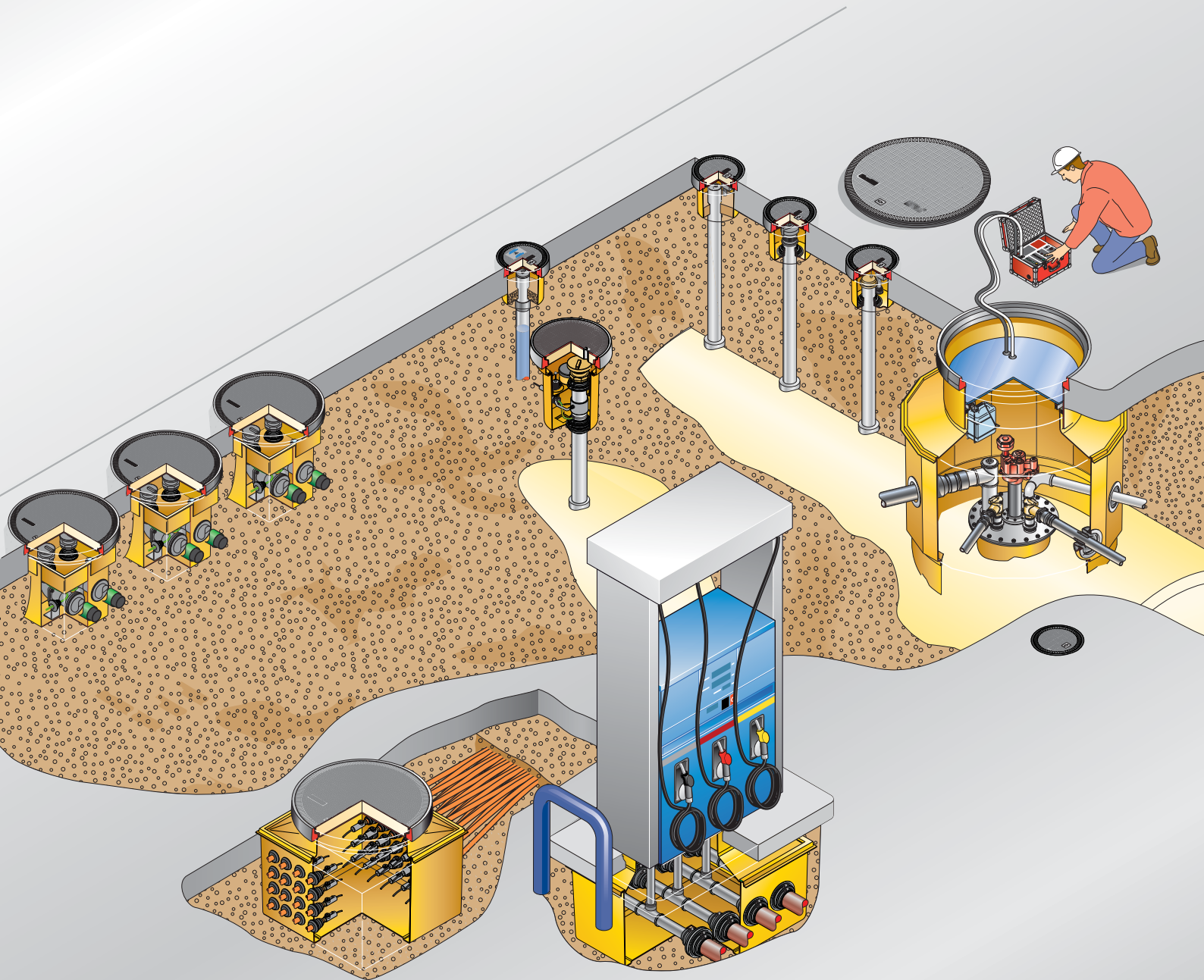

Shaping future standards

# Insight into Fibrelite

## Our global sales and support network

Fibrelite was established in 1980 and currently has three manufacturing plants around the world. Our head office and main manufacturing plant is located in England and serves the UK, Europe, Middle East and Africa. The Americas region is serviced by our US plant and sales office based in Connecticut. In 2011, Fibrelite opened a new manufacturing plant in Malaysia to supply products to the Asia Pacific region.

Fibrelite has an established global network of distributors, details of which can be found on our website.



Fibretec  
GROUP  
COMPANY

## Our commitment to maintaining high quality standards

Fibrelite has strict controls on raw material quality and manufacturing standards. All products are manufactured in accordance with ISO 9001:2008. ISO accreditation applies to the UK manufacturing plant.



FM 37923

Fibrelite's FL76, FL90 & FL760 D400 covers have been tested and accredited with the BSI Kitemark BS EN124 PAS 26 which is the unique standard for composite covers installed on petrol forecourts. This is your assurance that samples are regularly subjected to rigorous independent testing to ensure they comply with the stringent standards for safety, product performance and reliability. In addition, the Kitemark also means that the quality system of the factories where the covers are made are systematically assessed.



KM 40638



TANK AND  
DISPENSER SUMPS

Fibrelite is the first GRP tank chamber and dispenser sump manufacturer to attain KIWA approval. Sumps and integrating GRP components are manufactured using the (RTM) resin transfer moulding process. The closed mould production technique creates a consistent wall thickness and superior finish. Products are designed to withstand the highest ground water pressure consistently for the lifetime of a petrol station.

GRP components can be supplied with an integral conductive layer. This is supplied as standard with all our below ground fill products. For other products, this is optional. GRP material is impervious to water, petroleum products and biofuels.

## Technical Resources

Each system is fully supported with dimensional product drawings and installation instructions. Contact Fibrelite directly or log onto our website to access this information at [www.fibrelite.com](http://www.fibrelite.com)

## Personal Sales Support

If you require one-to-one guidance on which products best suit your design requirements, please call our sales team who will be pleased to assist you further. Our switchboard will direct you to your local area support manager.

UK, Europe, Africa, Middle East & Asia Pacific Tel +44 (0)1756 799773

North, South & Central America Tel: +1 800 422 2525

# Award winning designs

## Contents

<b>Product range</b>	<b>Page</b>
Round tank sumps	4 - 7
Square tank sumps	8
Multi-port tank sumps	9
Direct fill tank sumps	10
Direct fill spill buckets	11
Remote fill and VR1b containment systems	12
Dispenser sumps	13 - 14
Vent pipe transition sump	14
Tank riser access solutions	15
Monitoring well systems	16
Grounding point systems	16
Electrical drawpits	17
Retrofit tank connection systems	18
Tank sump internal lids and platforms	19
Accessories and maintenance items	19 - 20
Vacuum testing	21 - 23

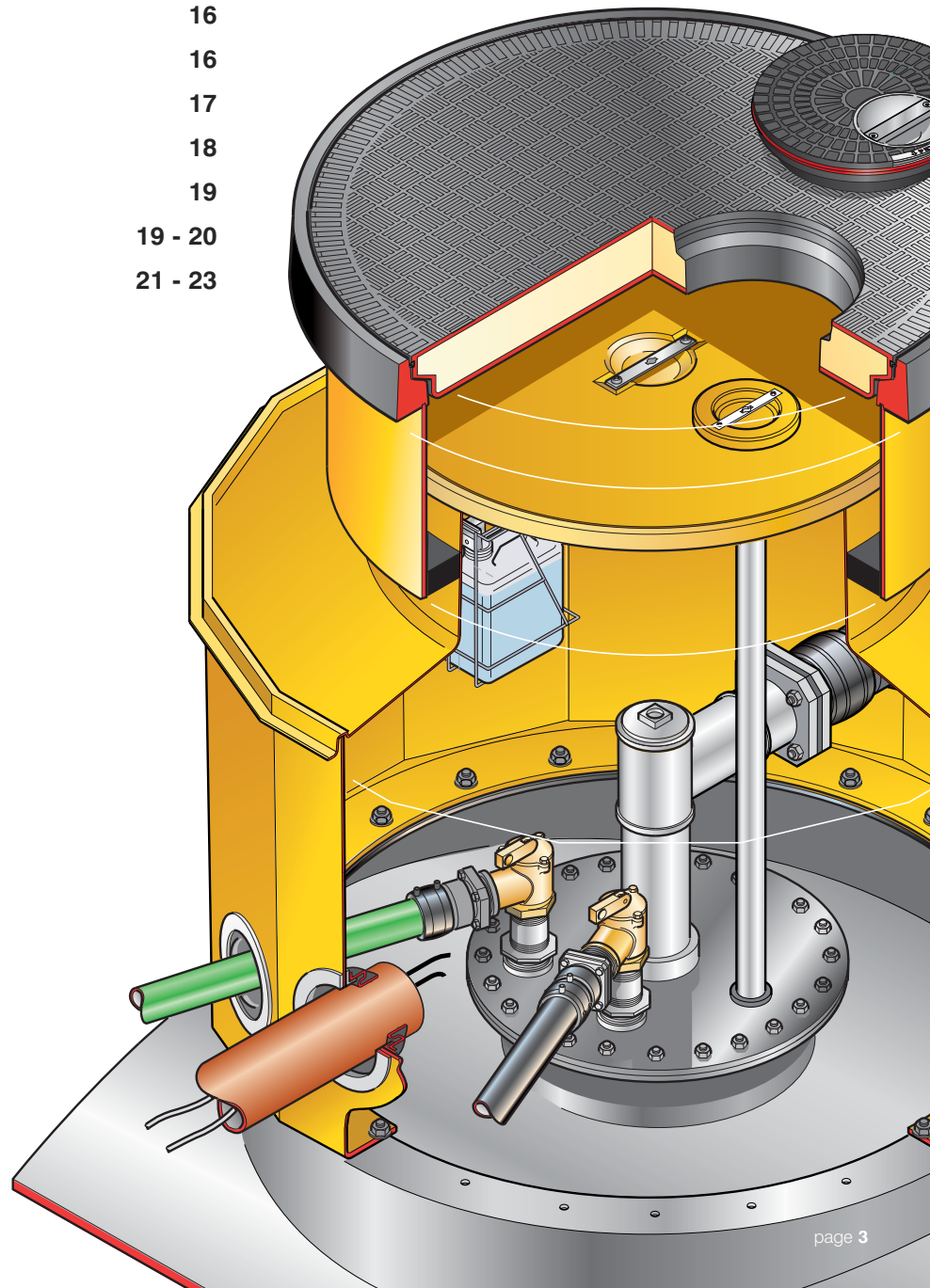

# Premium liquid-tight containment

## Round Height Adjustable Tank Sump Systems

Our flat multi-sided sumps are designed to withstand high ground water pressure and are the ideal solution for deep burial applications. Various tank connection systems are available as detailed below.

Solutions are available for both new and retro-fit installations.

The systems are adjustable height which allows easy installation and eliminates the potential for load transfer from the cover to the tank.

A non-structural internal lid is supplied as standard.

All systems are vacuum testable.

### Bolted Base Sumps

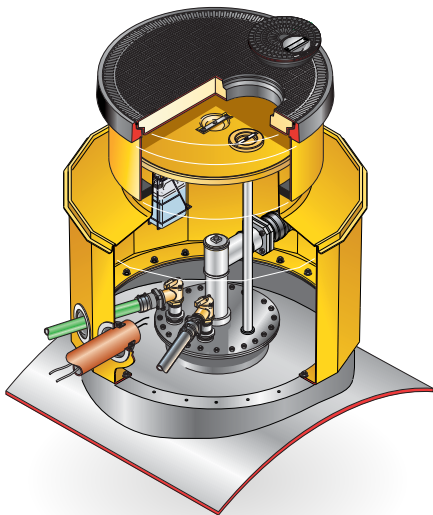

**S14-390/OD**

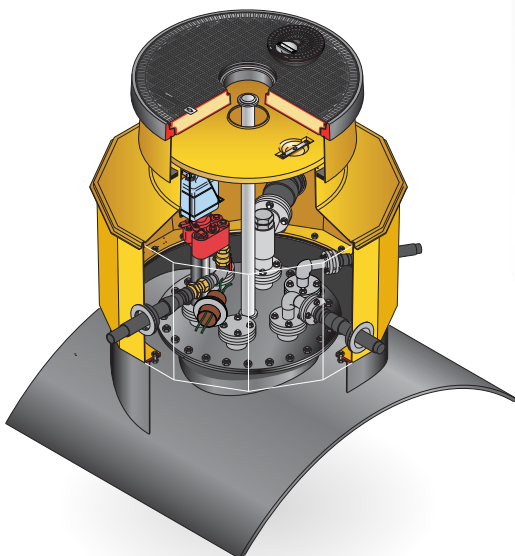

**S16-3100/CD**

#### Product Code Description

##### Round covers

S8-390	1.2m dia. sump with a corbel, skirt, non structural internal lid and 900mm dia. watertight flat sealed cover and frame
S8-390/CD	1.2m dia. sump with a corbel, skirt, non structural internal lid and 900mm dia. watertight flat sealed cover with a central dip port and frame
S8-390/OD	1.2m dia. sump with a corbel, skirt, non structural internal lid and 900mm dia. watertight flat sealed cover with an offset dip port and frame
S14-390	1.4m dia. sump with a corbel, skirt, non structural internal lid and 900mm dia. watertight flat sealed cover and frame
S14-390/CD	1.4m dia. sump with a corbel, skirt, non structural internal lid and 900mm dia. watertight flat sealed cover with a central dip port and frame
S14-390/OD	1.4m dia. sump with a corbel, skirt, non structural internal lid and 900mm dia. watertight flat sealed cover with an offset dip port and frame
S16-3100	1.5m dia. twelve sided sump with a corbel, skirt, non structural internal lid and 1020mm dia. watertight flat sealed cover and frame
S16-3100/CD	1.5m dia. twelve sided sump with a corbel, skirt, non structural internal lid and 1020mm dia. watertight flat sealed cover with a central dip port and frame
S16-3100/OD	1.5m dia. twelve sided sump with a corbel, skirt, non structural internal lid and 1020mm dia. watertight flat sealed cover with an offset dip port and frame

# Vacuum testable

## Bolted Base Sumps - continued

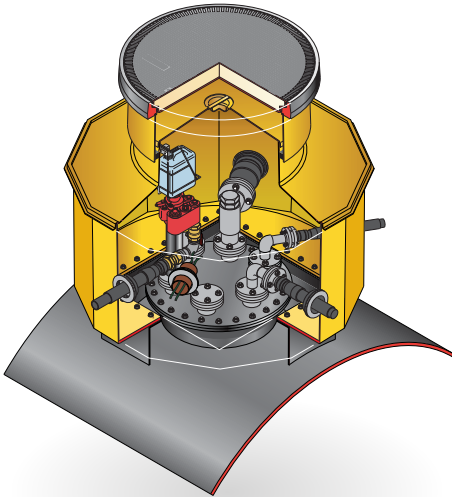

**S16SQ-390**

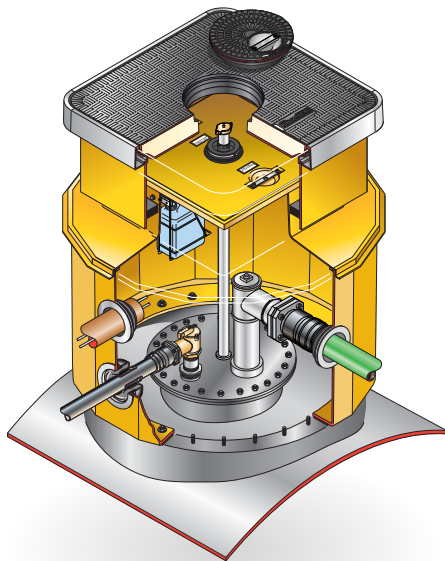

**S8-376/CD**

Product Code	Description
<b>Round covers - continued</b>	
S16SQ-390	1.5m dia. twelve sided sump with a 1m square bolted base, corbel, skirt, non-structural internal lid and 900mm dia. watertight flat sealed cover and frame
S16SQ-390/CD	1.5m dia. twelve sided sump with a 1m square bolted base, corbel, skirt, non-structural internal lid and 900mm dia. watertight flat sealed cover with a central dip port and frame
S16SQ-390/OD	1.5m dia. twelve sided sump with a 1m square bolted base, corbel, skirt, non-structural internal lid and 900mm dia. watertight flat sealed cover with an offset dip port and frame
S16SQ-3100	1.5m dia. twelve sided sump with a 1m square bolted base, corbel, skirt, non-structural internal lid and 1020mm dia. watertight flat sealed cover and frame
S16SQ-3100/CD	1.5m dia. twelve sided sump with a 1m square bolted base, corbel, skirt, non-structural internal lid and 1020mm dia. watertight flat sealed cover with a central dip port and frame
S16SQ-3100/OD	1.5m dia. twelve sided sump with a 1m square bolted base, corbel, skirt, non-structural internal lid and 1020mm dia. watertight flat sealed cover with an offset dip port and frame
<b>Square covers</b>	
S8-376	1.2m dia. sump with a corbel, skirt, non structural internal lid, and 760mm <sup>2</sup> watertight flat sealed cover and frame
S8-376/CD	1.2m dia. sump with a corbel, skirt, non-structural internal lid and 760mm <sup>2</sup> watertight flat sealed cover with a central dip port and frame

Order structural platforms separately for manual dip and fill risers if required. Refer to structural platform table for information.

The standard colour of the cover is black. Fill and dip caps can be colour coded to identify the fuel grade. Covers can be ordered in C250 or D400 load ratings.

# Designed to last the lifetime of a petrol station

## Collar Ring Base Sumps

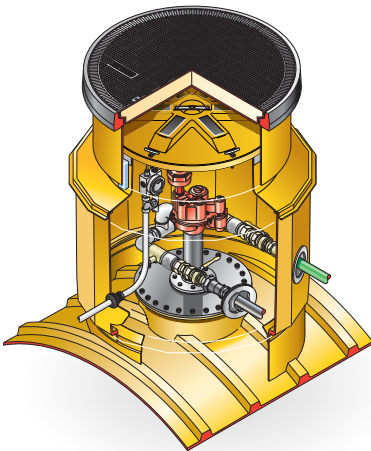

**S8CR-390/WT**

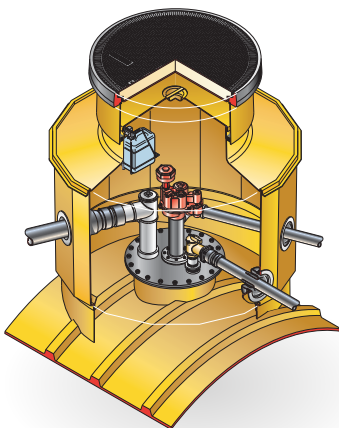

**S15CR-390**

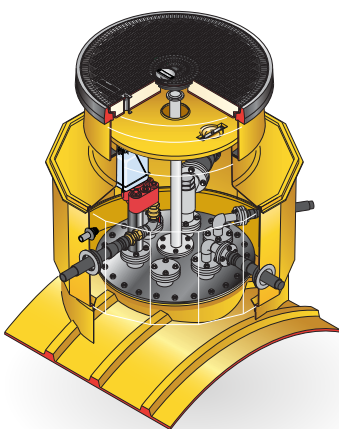

**S16CR-3100/CD**

Product Code	Description
--------------	-------------

Product Code	Description
<b>Round covers</b>	
S8CR-390	1.2m dia sump with a corbel, skirt, non structural internal lid and 900mm dia flat sealed cover and frame
S8CR-390/CD	1.2m dia sump with a corbel, skirt, non structural internal lid and 900mm dia flat sealed cover with a central dip port and frame
S8CR-390/OD	1.2m dia sump with a corbel, skirt, non structural internal lid and 900mm dia flat sealed cover with an offset dip port and frame
S8CR-390/WT	1.2m dia sump with a corbel, skirt, structural watertight internal lid and 900mm dia flat sealed cover and frame
S14CR-390	1.4m dia sump with a corbel, skirt, non structural internal lid and 900mm dia flat sealed cover and frame
S14CR-390/CD	1.4m dia sump with a corbel, skirt, non structural internal lid and 900mm dia flat sealed cover with a central dip port and frame
S14CR-390/OD	1.4m dia sump with a corbel, skirt, non structural internal lid and 900mm dia flat sealed cover with an offset dip port and frame
S14CR-390/WT	1.4m dia sump with a corbel, skirt, structural watertight internal lid and 900mm dia flat sealed cover and frame
S14CR-3100	1.4m dia sump with a corbel, skirt, non structural internal lid and 1020mm dia flat sealed cover and frame
S14CR-3100/CD	1.4m dia sump with a corbel, skirt, non structural internal lid and 1020mm dia flat sealed cover with a central dip port and frame
S14CR-3100/OD	1.4m dia sump with a corbel, skirt, non structural internal lid and 1020mm dia flat sealed cover with an offset dip port and frame
S14CR-3100/WT	1.4m dia sump with a corbel, skirt, structural watertight internal lid and 1020mm dia flat sealed cover and frame
S15CR-390	1.45m dia. sixteen sided sump with a corbel, skirt, non structural internal lid and 900mm dia. watertight flat sealed cover and frame
S15CR-3100	1.45m dia. sixteen sided sump with a corbel, skirt, non structural internal lid and 1020mm dia. watertight flat sealed cover and frame
S15CR-390/CD	1.45m dia. sixteen sided sump with a corbel, skirt, non structural internal lid and 900mm dia. watertight flat sealed cover with a central dip port and frame
S15CR-390/OD	1.45m dia. sixteen sided sump with a corbel, skirt, non structural internal lid and 900mm dia. watertight flat sealed cover with an offset dip port and frame
S15CR-390/WT	1.45m dia sixteen sided sump with a corbel, skirt, structural watertight internal lid and 900mm dia flat sealed cover and frame
S15CR-3100/CF	1.45m dia. sixteen sided sump with a corbel, skirt, non structural internal lid and 1020mm dia. watertight flat sealed cover with a central fill port and frame
S15CR-3100/OF	1.45m dia. sixteen sided sump with a corbel, skirt, non structural internal lid and 1020mm dia. watertight flat sealed cover with an offset fill port and frame
S16CR-3100	1.5m dia. twelve sided sump with a corbel, skirt, non structural internal lid & 1020mm dia. watertight flat sealed cover & frame
S16CR-3100/CD	1.5m dia. twelve sided sump with a corbel, skirt, non structural internal lid and 1020mm dia. watertight flat sealed cover with a central dip port and frame
S16CR-3100/OD	1.5m dia. twelve sided sump with a corbel, skirt, non structural internal lid and 1020mm dia. watertight flat sealed cover with an offset dip port and frame
S16CR-3100/CF	1.5m dia. twelve sided sump with a corbel, skirt, non structural internal lid and 1020mm dia. watertight flat sealed cover with a central fill port and frame
S16CR-3100/OF	1.5m dia. twelve sided sump with a corbel, skirt, non structural internal lid and 1020mm dia. watertight flat sealed cover with an offset fill port and frame

# No load transfer from the cover to the tank

## Solid Base Sumps

### Shallow/Standard Burial Solid Base Sumps

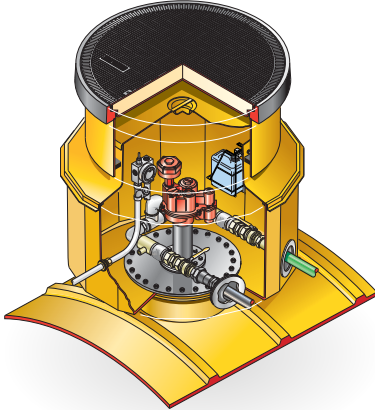

**S8SB-390**

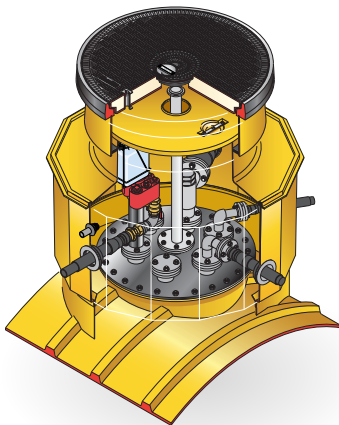

**S8SBD-390/CD**

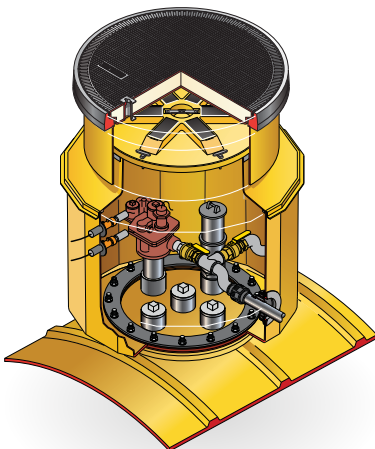

**S8SBD-390/WT**

Product Code	Description
<b>Round covers</b>	
S8SB-390	1.2m dia. sump with a corbel, skirt, non structural internal lid and 900mm dia. watertight flat sealed cover and frame
S8SB-390/CD	1.2m dia. sump with a corbel, skirt, non structural internal lid and 900mm dia. watertight flat sealed cover with a central dip port and frame
S8SB-390/OD	1.2m dia. sump with a corbel, skirt, non structural internal lid and 900mm dia. watertight flat sealed cover with an offset dip port and frame
S8SB-390/WT	1.2m dia sump with a corbel, skirt, structural watertight internal lid and 900mm dia flat sealed cover and frame
S8SB-3100	1.2m dia. sump with a corbel, skirt, non structural internal lid and 1020mm dia. watertight flat sealed cover and frame
S8SB-3100/CD	1.2m dia. sump with a corbel, skirt, non structural internal lid and 1020mm dia. watertight flat sealed cover with a central dip port and frame
S8SB-3100/OD	1.2m dia. sump with a corbel, skirt, non structural internal lid and 1020mm dia. watertight flat sealed cover with an offset dip port and frame
S8SB-3100/CF	1.2m dia. sump with a corbel, skirt, non structural internal lid and 1020mm dia. watertight flat sealed cover with a central fill port and frame
S8SB-3100/OF	1.2m dia. sump with a corbel, skirt, non structural internal lid and 1020mm dia. watertight flat sealed cover with an offset fill port and frame
S8SB-3100/WT	1.2m dia sump with a corbel, skirt, structural watertight internal lid and 1020mm dia flat sealed cover and frame
<b>Square covers</b>	
S8SB-376	1.2m dia. sump with a corbel, skirt, non structural internal lid and 760mm <sup>2</sup> watertight flat sealed cover and frame
S8SB-376/CD	1.2m dia. sump with a corbel, skirt, non-structural internal lid and 760mm <sup>2</sup> watertight flat sealed cover with a central dip port and frame

### Deep/Standard Burial Solid Base Sumps

Product Code	Description
<b>Round covers</b>	
S8SBD-390	1.2m dia sump with a corbel, skirt, non structural internal lid and 900mm dia flat sealed cover and frame
S8SBD-390/CD	1.2m dia sump with a corbel, skirt, non structural internal lid and 900mm dia flat sealed cover with a central dip port and frame
S8SBD-390/OD	1.2m dia sump with a corbel, skirt, non structural internal lid and 900mm dia flat sealed cover with a offset dip port and frame
S8SBD-390/WT	1.2m dia sump with a corbel, skirt, structural watertight internal lid and 900mm dia flat sealed cover and frame
S8SBD-3100	1.2m dia sump with a corbel, skirt, non structural internal lid and 1020mm dia flat sealed cover and frame
S8SBD-3100/CD	1.2m dia sump with a corbel, skirt, non structural internal lid and 1020mm dia flat sealed cover with a central dip port and frame
S8SBD-3100/OD	1.2m dia sump with a corbel, skirt, non structural internal lid and 1020mm dia flat sealed cover with a offset dip port and frame
S8SBD-3100/WT	1.2m dia sump with a corbel, skirt, structural watertight internal lid and 1020mm dia flat sealed cover and frame

# Premier engineered design

## Square Height Adjustable Tank Chamber Systems

Designed to be bolted onto square tank upstands, our GRP range offers a great alternative to metal sumps which frequently corrode and leak around pipework penetrations.

The systems are adjustable height which allows easy installation and eliminates the potential for load transfer from the cover to the tank. A non-structural internal lid is supplied as standard. Square systems can only be buried up to 1.8 metres deep. All systems are vacuum testable.

### Bolted base systems with watertight flat sealed covers

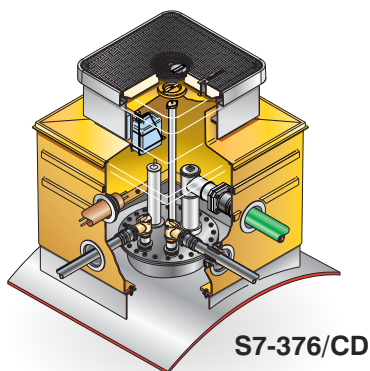

S7-376/CD

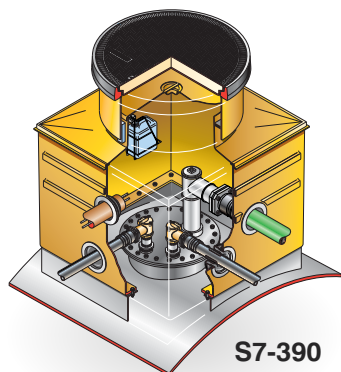

S7-390

Product Code	Description
S6-376	1.2m <sup>2</sup> chamber with a corbel, skirt, non-structural internal lid and 760mm <sup>2</sup> flat sealed cover and frame. Chamber has a 1m <sup>2</sup> tank upstand connection.
S6-376/CD	1.2m <sup>2</sup> chamber with a corbel, skirt, non-structural internal lid, 760mm <sup>2</sup> flat sealed cover with central dip port and frame. Chamber has a 1m <sup>2</sup> tank upstand connection.
S6-390	1.2m <sup>2</sup> chamber with a corbel, skirt, non-structural internal lid and 900mm dia. flat sealed cover and frame. Chamber has a 1m <sup>2</sup> tank upstand connection.
S6-390/CD	1.2m <sup>2</sup> chamber with a corbel, skirt, non-structural internal lid and 900mm dia. flat sealed cover with a central dip port and frame. Chamber has a 1m <sup>2</sup> tank upstand connection.
S6-390/OD	1.2m <sup>2</sup> chamber with a corbel, skirt, non-structural internal lid and 900mm dia. flat sealed cover with an offset dip port and frame. Chamber has a 1m <sup>2</sup> tank upstand connection.
S7-376	1.2m <sup>2</sup> chamber with a corbel, skirt, non-structural internal lid and 760mm <sup>2</sup> flat sealed cover and frame.
S7-376/CD	1.2m <sup>2</sup> chamber with a corbel, skirt, non-structural internal lid, 760mm <sup>2</sup> flat sealed cover with central dip port and frame.
S7-390	1.2m <sup>2</sup> chamber with a corbel, skirt, non-structural internal lid and 900mm dia. flat sealed cover and frame.
S7-390/CD	1.2m <sup>2</sup> chamber with a corbel, skirt, non-structural internal lid and 900mm dia. flat sealed cover with a central dip port and frame.
S7-390/OD	1.2m <sup>2</sup> chamber with a corbel, skirt, non-structural internal lid and 900mm dia. flat sealed cover with an offset dip port and frame.
S18-3100	1250mm x 1450mm chamber with a corbel, skirt, non structural internal lid and 1020mm dia flat sealed cover and frame.

Solid base systems are available if required. Order structural platforms separately for manual dip and fill risers if required. Refer to structural platform table for information. The standard colour of the cover is black. Fill and dip caps can be colour coded to identify the fuel grade. Covers can be ordered in C250 or D400 load ratings.

### Bolted base systems with raised raintight cover

Our basic range of square tank chamber systems are supplied with a non-watertight raised cover. The system allows surface rainwater to drain between the skirt and chamber riser into the ground.

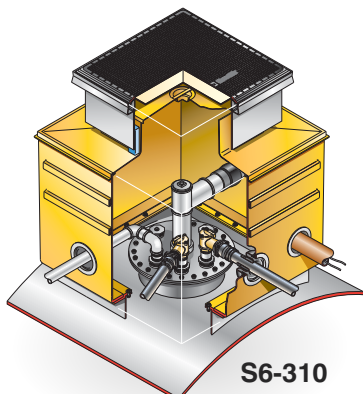

S6-310

Product Code	Description
S6-310	1.2m <sup>2</sup> chamber with a corbel, skirt, non-structural internal lid and 766mm <sup>2</sup> raised cover and frame. Chamber has a 1m <sup>2</sup> tank upstand connection.
S6-336	1.2m <sup>2</sup> chamber with a corbel, skirt, non-structural internal lid and 900mm dia. raised cover and frame. Chamber has a 1m <sup>2</sup> tank upstand connection.
S7-310	1.2m <sup>2</sup> chamber with a corbel, skirt, non-structural internal lid and 766mm <sup>2</sup> raised cover and frame.
S7-336	1.2m <sup>2</sup> chamber with a corbel, skirt, non-structural internal lid and 900mm dia. raised cover and frame.

Solid base systems are available if required.



# Consistent structural integrity

## Multi Port Tank Sumps

Fibrelite has designed a new range of multi-port systems. The two ports can be used for various applications, including direct fill, vapour recovery, manual dip and also as inspection ports. FL90 MP & FL100 MP covers can be installed over any round tank sump system. Systems can be supplied with or without a drainback system to the tank.

Please contact us for further information.

Product Code	Description
S8CR-390/MP	1.2m dia. sump with a collar ring base, corbel, skirt, spill container, 900mm dia. watertight flat sealed cover with two ports and sealed caps & frame. Observation cap. Two riser pipe sealkits. Half a tin of sealant
S8CR-3100/MP	1.2m dia. sump with a collar ring base, corbel, skirt, spill container, 1020mm dia. watertight flat sealed cover with two ports and sealed caps & frame. Observation cap. Two riser pipe sealkits. Half a tin of sealant
S15CR-390/MP	1.45m dia. sump with a collar ring base, corbel, skirt, spill container, 900mm dia. watertight flat sealed cover with two ports and sealed caps & frame. Observation cap. Two riser pipe sealkits. Half a tin of sealant
S15CR-3100/MP	1.45m dia. sump with a collar ring base, corbel, skirt, spill container, 1020mm dia. watertight flat sealed cover with two ports and sealed caps & frame. Observation cap. Two riser pipe sealkits. Half a tin of sealant

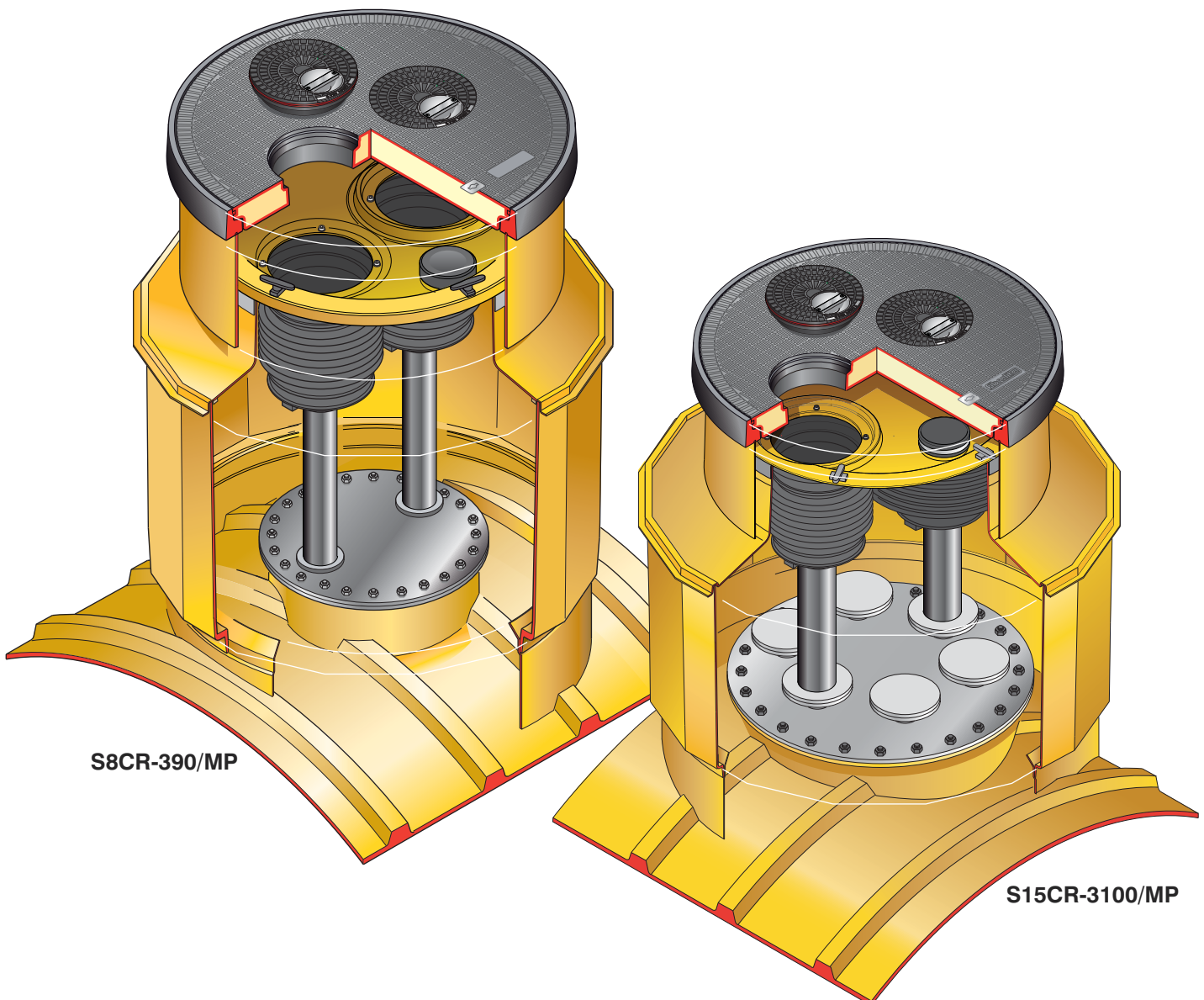

# Liquidtight secondary contained direct fill

## Direct Fill Tank Sumps

Fibrelite's large multi-sided tank sumps can contain direct fill risers installed on the manway lid, or will contain several tank risers grouped together on the tank.

Systems are supplied with a structural spill container, which can be connected to an additional spill bucket if required. The sump provides sufficient space to install further pipe connections and a turbine pump if required.

The spill container can be removed easily for maintenance. Central and offset fill ports are available.

If access is required to reach the manual dipstick, please refer to the multi-port tank sump section.

Systems are vacuum testable.

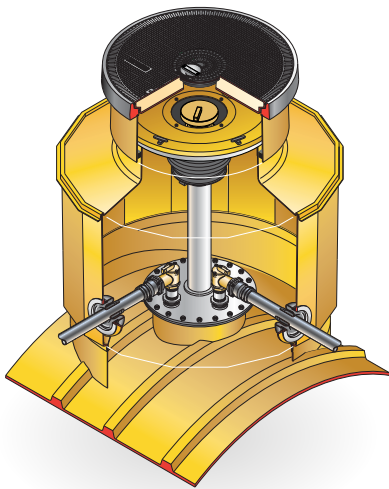

**S15CR-390/CF**

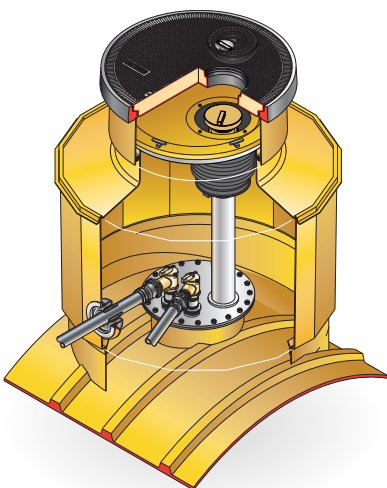

**S16CR-3100/OF**

### Product Code Description

S8CR-390/CF	1.2m dia. sump with a collar ring base, corbel, skirt, spill container, 900mm dia. watertight flat sealed cover with a central fill port, sealed cap & frame. Observation cap. One riser pipe seal kit. Half a tin of sealant
S8CR-390/OF	1.2m dia. sump with a collar ring base, corbel, skirt, spill container, 900mm dia. watertight flat sealed cover with an offset fill port, sealed cap & frame. Observation cap. One riser pipe seal kit. Half a tin of sealant
S8CR-3100/CF	1.2m dia. sump with a collar ring base, corbel, skirt, spill container, 1020mm dia. watertight flat sealed cover with a central fill port, sealed cap & frame. Observation cap. One riser pipe seal kit. Half a tin of sealant
S8CR-3100/OF	1.2m dia. sump with a collar ring base, corbel, skirt, spill container, 1020mm dia. watertight flat sealed cover with an offset fill port, sealed cap & frame. Observation cap. One riser pipe seal kit. Half a tin of sealant
S15CR-390/CF	1.45m dia. sixteen sided sump with a collar ring base, corbel, skirt, spill container, 900mm dia. watertight flat sealed cover with a central fill port, sealed cap & frame. Observation cap. One riser pipe seal kit. Half a tin of sealant
S15CR-390/OF	1.45m dia. sixteen sided sump with a collar ring base, corbel, skirt, spill container, 900mm dia. watertight flat sealed cover with an offset fill port, sealed cap & frame. Observation cap. One riser pipe seal kit. Half a tin of sealant
S15CR-3100/CF	1.45m dia. sixteen sided sump with a collar ring base, corbel, skirt, spill container, 1020mm dia. watertight flat sealed cover with a central fill port, sealed cap & frame. Observation cap. One riser pipe seal kit. Half a tin of sealant
S15CR-3100/OF	1.45m dia. sixteen sided sump with a collar ring base, corbel, skirt, spill container, 1020mm dia. watertight flat sealed cover with an offset fill port, sealed cap & frame. Observation cap. One riser pipe seal kit. Half a tin of sealant
S16CR-390/CF	1.45m dia. twelve sided sump with a collar ring, corbel base, skirt, spill container, 900mm dia. watertight flat sealed cover with a central fill port, sealed cap & frame. Observation cap. One riser pipe seal kit. Half a tin of sealant
S16CR-390/OF	1.45m dia. twelve sided sump with a collar ring base, corbel, skirt, spill container, 900mm dia. watertight flat sealed cover with an offset fill port, sealed cap & frame. Observation cap. One riser pipe seal kit. Half a tin of sealant
S16CR-3100/CF	1.45m dia. twelve sided sump with a collar ring base, corbel, skirt, spill container, 1020mm dia. watertight flat sealed cover with a central fill port, sealed cap & frame. Observation cap. One riser pipe seal kit. Half a tin of sealant
S16CR-3100/OF	1.45m dia. twelve sided sump with a collar ring base, corbel, skirt, spill container, 1020mm dia. watertight flat sealed cover with an offset fill port, sealed cap & frame. Observation cap. One riser pipe seal kit. Half a tin of sealant

## GRP Below Ground Secondary Containment Systems

Our new range of secondary contained spill buckets are designed for either remote fill or direct fill installations. These systems provide a non-corrosive liquid-tight solution which can be vacuum tested. Systems are designed to contain either single or double wall pipework.

### Secondary Contained Direct Fill Spill Buckets

Our new GRP secondary contained direct fill spill buckets are available with or without a drainback to the tank. Covers can be colour coded to the fuel grade.

Product Code	Description
S45-1180/DFD	450mm dia. x 675mm deep solid base sump, with a spill container, integrated drainback system to the tank, 450mm dia. flat sealed cover and frame. Observation port cap. Grounding cable sealkit. Fill riser sealkit.
S45-1180/DF	450mm dia. x 675mm deep solid base sump with a spill container, 450mm dia. flat sealed cover and frame. Observation port cap. Grounding cable sealkit. Fill riser sealkit. Fill pipe located centrally to provide a retro-fit solution for leaking spill containers.

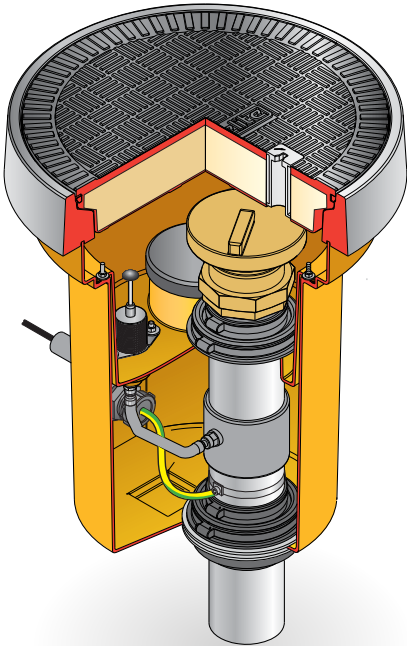

**S45-1180/DFD  
with drainback**

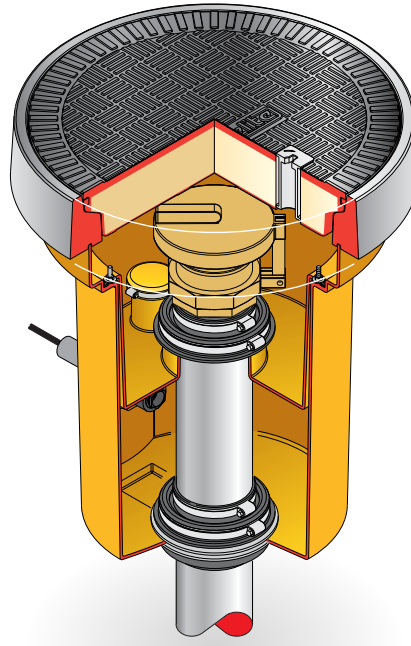

**S45-1180/DF  
without drainback**

# The number one choice of all global major oil

## GRP Below Ground Secondary Containment Systems

### Secondary Contained Remote Fill Systems

Our new GRP secondary contained remote fill systems are designed to house a combination of fill and vapour recovery pipework. Pipework can be factory fitted and tested if required. Systems are available with or without a drainback. Covers can be colour coded to the fuel grade.

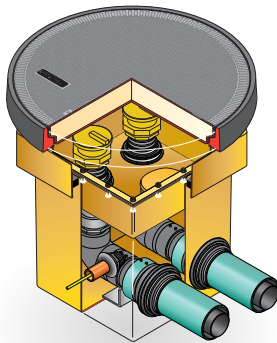

**S2-3760/OF  
No drainback**

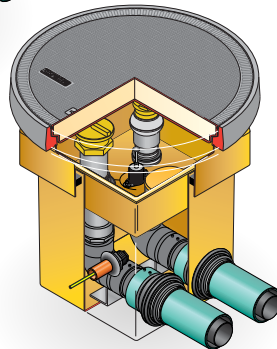

**S2-3760/OF  
With drainback**

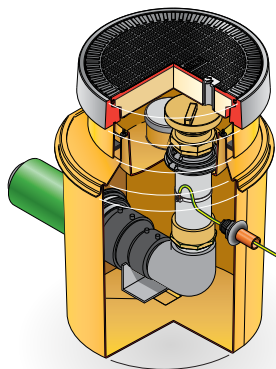

**S57-3180/OF**

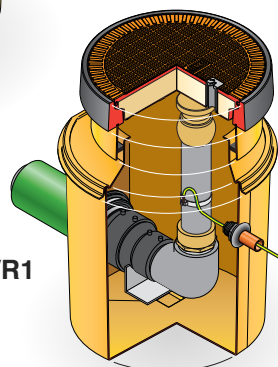

**S57-3180/VR1**

### Multiple Pipe Containment

Product Code	Description
S2-3760/OFD	600mm cubed remote fill sump with adjustable skirt, spill container, 760mm dia. flat sealed cover and frame. Half tin of sealant. Integrated drainback system included. Grounding cable sealkit.
S2-3760/OF	600mm cubed remote fill sump with adjustable skirt, spill container, 760mm dia. flat sealed cover and frame. Half tin of sealant. Grounding cable sealkit.

The following pipework configurations are available: 2 fills or 1 fill (with or without drainback) 2 fills with 1 VR1b (no drainback) 1 VR1b

### Single Pipe Containment

Product Code	Description
S57-3180/OFD	570mm dia. x 635mm deep solid base sump with a sealed secondary spill container with a drainback. 450mm dia. flat sealed cover and frame. Includes PSB/110/PS 110mm dia. fill riser sealkit, grounding cable sealkit and one double sided PSBD/160 sealkit. Fits 1 remote fill.
S57-3180/OF	570mm dia. x 635mm deep solid base sump with a sealed secondary spill container. 450mm dia. flat sealed cover and frame. Includes PSB/110/PS 110mm dia. fill riser sealkit, grounding cable sealkit and one double sided PSBD/160 sealkit. Fits 1 remote fill.
S57-3180/VR1	570mm dia. x 635mm deep solid base sump with skirt and a 450mm dia. flat sealed cover and frame. Includes a grounding cable sealkit and one double sided PSBD/160 sealkit. Fits 1 VR1b.

**WARNING:** Spill buckets may contain a large amount of vapour and petroleum products which may have been spilt during unloading. For this reason we recommend the installation of Fibrelite double sided boots to seal all penetrations.

## Dispenser Sump Systems

### Standard Sump Range

Our new vacuum testable GRP dispenser sump range offers a great alternative to polyethylene sumps. The strong rigid GRP structure will not deflect under ground water pressure. The simple two piece design provides a large working space to install pipework inside the sump, before the top section is installed.

Product Code	Description
	<b>Dresser Wayne</b>
EL/W/OVA	Fits Wayne Ovation
EL/W/VIS/35	Fits Wayne Vista 35 (narrow 35" body)
EL/W/VIS/35/DC	Fits Wayne Vista 35 (narrow 35" body) for double canopy installations
EL/W/VIS/48	Fits Wayne Vista 48 (wide 48" body)
EL/W/VIS/48/DC	Fits Wayne Vista 48 (narrow 48" body) for double canopy installations
EL/W/VIS/387	Fits Wayne Vista 380 (387)
EL/W/VIS/390 & 399	Fits Wayne Vista 390 (390, 399)
EL/W/GC/G2200	Fits Wayne Global Century (G2000, G2200)
EL/W/GS2	Fits Wayne Global Star CXX -21
EL/W/GS2/AB	Fits Wayne Global Star Ad Blue 2 hose
EL/W/GS6	Fits Wayne Global Star CXX – 32
EL/W/GS4	Fits Wayne Global Star CXX – 33
EL/W/GS8	Fits Wayne Global Star CXX – 44
EL/W/SATII	Fits Wayne Satellite II
EL/W/MECH	Fits Wayne Mechanical Pump 2-7040C and DL1361
	<b>Gilbarco</b>
EL/G/ADV/36	Fits Gilbarco Advantage (narrow body 36")
EL/G/ADV/48	Fits Gilbarco Advantage (wide body 48")
EL/G/E500	Fits Gilbarco Encore 500, 500S
EL/G/E500/NB	Fits Gilbarco Encore (narrow body 21")
EL/G/E/JT1200GB	Fits Gilbarco Endeavor (JT1200GB)
EL/G/ELEC	Fits Gilbarco Electroline (1-4 hose)
EL/G/ENT	Fits Gilbarco Australia Enterprise
EL/G/EURO/2-4	Fits Gilbarco Euroline (1 to 4 hose)
EL/G/HOR	Fits Gilbarco Horizon
EL/G/LEG	Fits Gilbarco Legacy
EL/G/SK700	Fits Gilbarco SK700 Series II
	<b>Tokheim</b>
EL/T/Q300T	Fits Tokheim Quantum 300T
EL/T/Q400T	Fits Tokheim Quantum 400T
EL/T/Q500T	Fits Tokheim Quantum 500T (LPG)
EL/T/Q410	Fits Tokheim Quantum 410
EL/T/Q510	Fits Tokheim Quantum 510
EL/T/QT/AB	Fits Tokheim Quantum AdBlue
	<b>Tatsuno</b>
EL/TAT/CRSUNNY	Fits Tatsuno CR Sunny
EL/TAT/NSUNNY	Fits Tatsuno Neo Sunny
EL/TAT/SUNNYXE	Fits Tatsuno Sunny XE (5-10 hose)
EL/TAT/SM1010	Fits Tatsuno Salesmaker SM1010,101,1020,1021 (1-4 hose)
EL/TAT/SM1060	Fits Tatsuno Salesmaker SM1060 (3-6 hose)
EL/TAT/SM1080	Fits Tatsuno Salesmaker SM1080 (4-8 hose)
EL/TAT/STM244	Fits Tatsuno STM -244
EL/TAT/STM362	Fits Tatsuno STM-362
EL/TAT/GAA1222	Fits Tatsuno GAA 1222
EL/TAT/GAB3662	Fits Tatsuno GAB 3662
	<b>Gasboy</b>
EL46-26/GB/9840-50	Fits Gasboy Atlas 9800 (9840,9850)
	<b>Bennett</b>
EL/B/3811	Fits Bennett 3000 (3811SNR)
	<b>Pumprtronics</b>
EL/PT/MONO/SCS	Fits Pumprtronics Series C Mono (SC11LC)
	<b>Accessories</b>
MPK/10	Shear valve mounting plate kit to fit OPW shear valves
MPK/10/S	Suction system riser pipe mounting plate kit

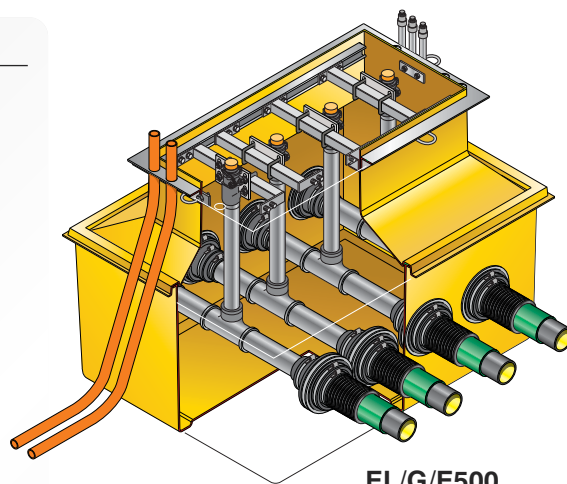

EL/G/E500

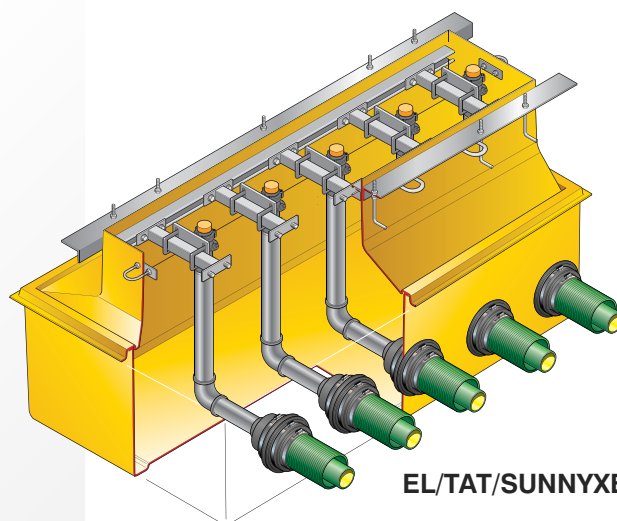

EL/TAT/SUNNYXE

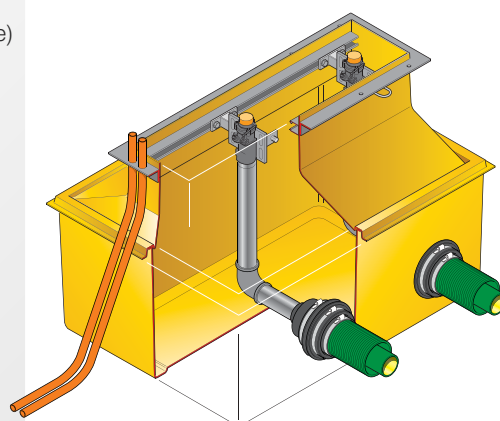

EL/W/VIS/48

For other dispenser models, please contact Fibrelite.

# High grade one piece composite structures

## Dispenser Sump Systems

### Retro-fit Sump Range

The retro-fit range of sumps is designed to allow new dispenser models to be retro-fitted to the existing sump, without breaking concrete. Only the top plinth needs replacing on the island. The dispenser is bolted to adjustable rails, which can be positioned to fit a variety of footprints. This provides a cost-effective long term solution for underground containment.

The shear valve rail is UL approved and should be ordered separately.

#### Product Code Description

EL46-20	1170mm x 660mm x 510mm sump with GRP top, 2 dispensers rails and fixing system
EL46-26	1170mm x 660mm x 750mm sump with GRP top, 2 dispensers rails and fixing system
EL46-38	1170mm x 660mm x 980mm sump with GRP top, 2 dispensers rails and fixing system
EL46-26/SVR	Stainless steel UL approved shear valve rail
MPK-10	Shear valve mounting plate kit, to fit OPW shear valves
MPK-10/S	Suction system riser pipe mounting plate kit

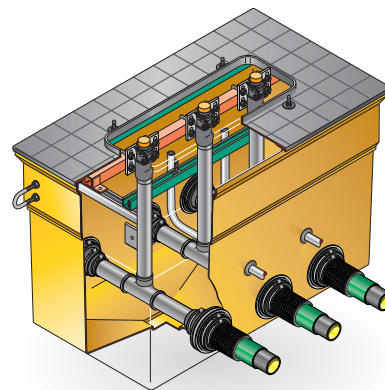

**EL46-26**

## Vent Pipe Transition Sump

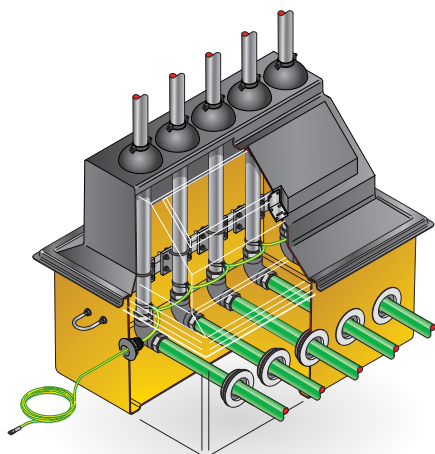

**S11-2/VENT**

Our new GRP vent pipe transition sump provides a strong watertight non-corrosive alternative to other products on the market. The system comes complete with a lockable hinged door to allow secure but easy access inside the sump. Internal aluminium pipework support is included as standard.

The above-ground section is pigmented black. This is UV stable and does not need to be painted. This is a maintenance free, cost effective containment solution.

#### Product Code Description

S11-2/VENT	1100mm x 800mm x 525mm deep GRP solid base sump with a 450mm high above ground sealed top with a hinged lockable door. Pipework support. Vent riser mounting brackets and pipe and conduit penetration seals must be purchased separately.
MPK/VENT	Vent riser mounting plate

# Anti-static and non-corrosive

## Tank Riser Access Solutions

When tank risers are located off the manway lid, additional containment solutions are required. Fibrelite offers a range of non-corrosive, watertight products to house the manual dip, ATG and the tank interstitial monitor riser. There is a choice of a fully contained system with a solid base sump, or an open base system.

Product Code	Description
<b>Contained Systems</b>	
S0-1120/MD	300mm dia. GRP solid base sump with a 63mm, 75mm or 110mm entry seal boot for the dip riser, watertight flat sealed cover and frame.
S0-1120/IM	300mm dia. GRP solid base sump with a 63mm, 75mm or 110mm entry seal boot for the riser pipe, watertight flat sealed cover and frame.
S0-1120/ATG1	300mm dia. GRP solid base sump with a 110mm entry seal boot for the ATG riser, a 27mm or 32mm conduit entry seal boot, watertight flat sealed cover and frame
S0-1120/ATG2	As ATG1, with two 27mm or two 32mm conduit entry seal boots.
S45-1180	450mm dia. GRP solid base sump with watertight flat sealed cover and frame. Designed to house two 110mm dia. risers (ATG, manual dip & tank interstitial) and two conduits. Pipe & conduit entry sealkits should be purchased separately.
S60-2600	600mm dia GRP solid base sump, skirt, with watertight flat sealed cover and frame. Various applications
<b>Open Base System</b>	
FL120, FL120/SK300	300mm dia. watertight sealed cover with frame and 300mm deep GRP skirt.

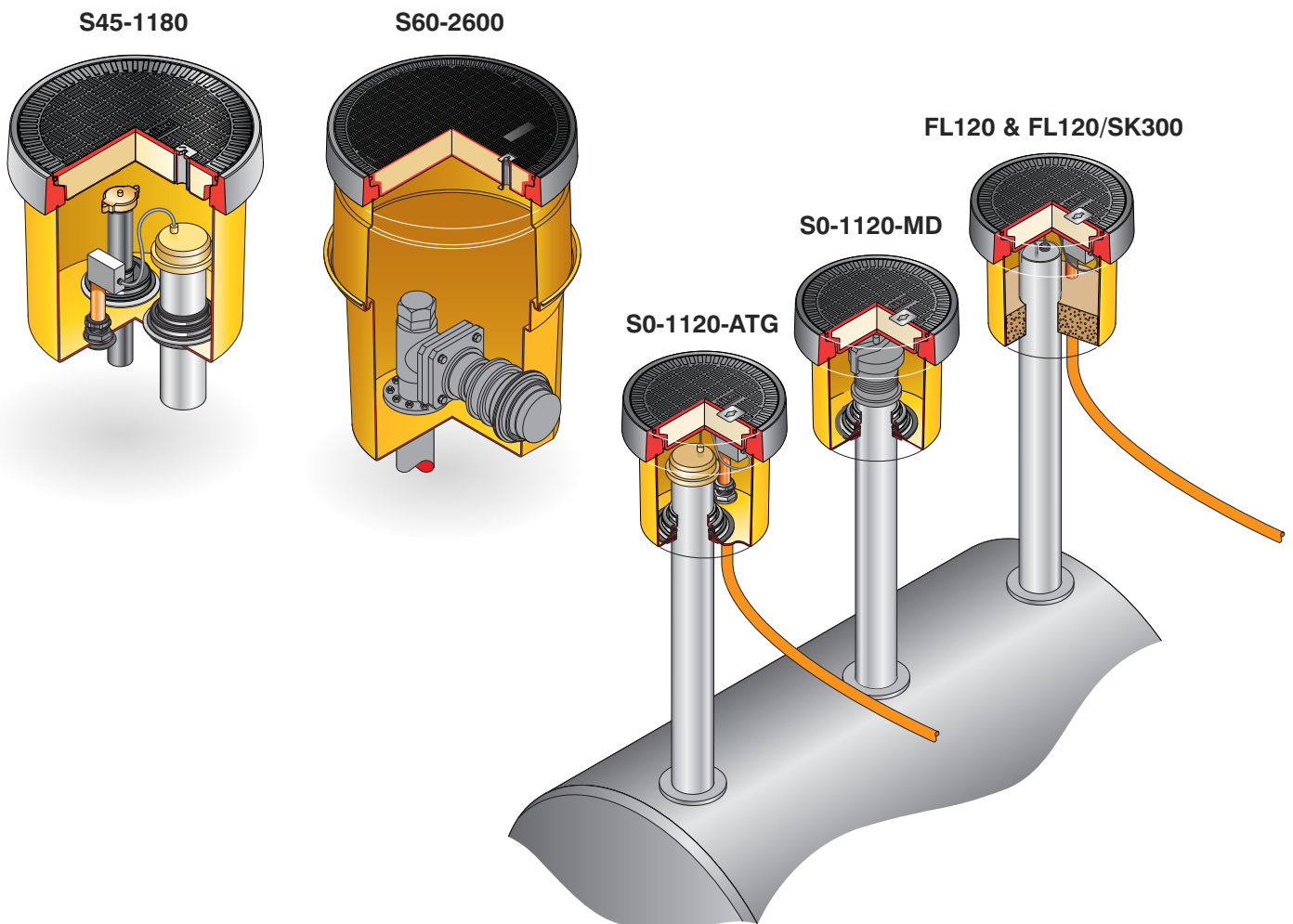

# Compliant to global safety standards

## Monitoring Well Systems

Fibrelite's new GRP monitoring well systems offer a great alternative to metal products on the market, which rust easily.

There is a choice of a contained system with a solid base sump or a basic system with an open base to the ground. Both systems are sealed at grade level with a Fibrelite watertight sealed cover, with a "DO NOT FILL" ID warning moulded into the surface of the cover.

Standard colour of the cover is grey with a black ID warning .

### Product Code Description

S0-1120/MW	300mm dia. solid base GRP sump with a 300mm watertight sealed monitoring well cover and frame.
FL120/MWS	300mm watertight sealed monitoring well cover, frame and 300mm deep GRP skirt

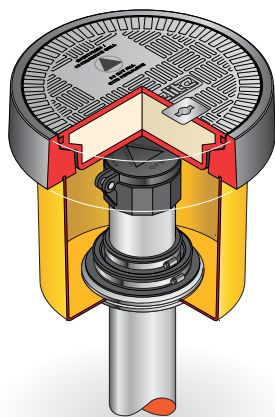

S0-1120/MW

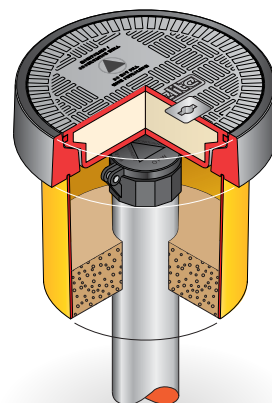

FL120/MWS

## Grounding Point Systems

Fibrelite has a new range of grounding point containment systems, which can be supplied with or without a sealed base. Covers can be colour coded if required.

### Product Code Description

S0-1120/GP	300mm dia. solid base sump with a 300mm watertight sealed cover and frame. Sealing fitting must be purchased separately.
FL120/GPS	300mm dia. watertight sealed cover with frame and 300mm deep GRP skirt.

Covers can be supplied with a "Grounding Point" ID moulded onto the surface.

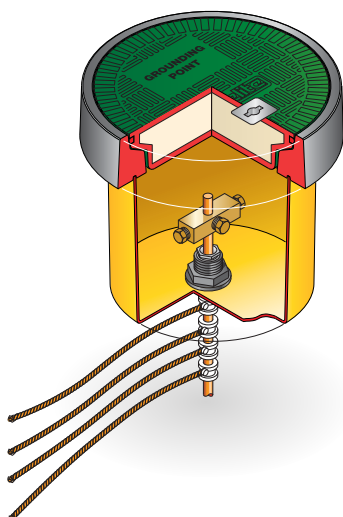

S0-1120/GP

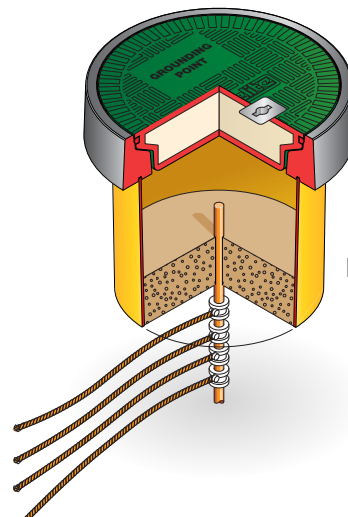

FL120/GPS



# GRP watertight solutions

## Electrical Drawpits

### Fixed & Adjustable Height Systems

The electrical drawpit range offers a perfect watertight containment solution.

There is a choice of either fixed height or adjustable height systems.

The adjustable height system includes a skirt, which allows the frame to be set to grade level more easily during installation. All systems are completed at grade level with a Fibrelite watertight sealed cover.

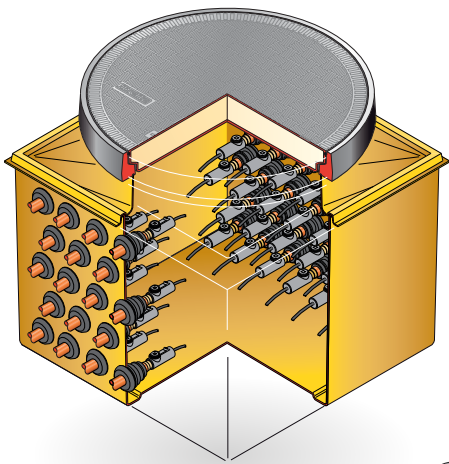

**S80-2760**

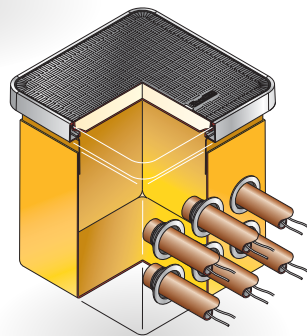

**S4-376/SKIRT**

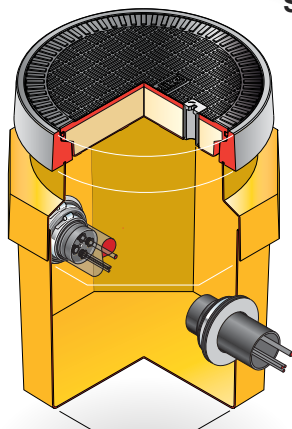

**S60-3180**

### Fixed Height Systems

#### Product Code Description

S1-1450	450mm <sup>2</sup> x 600mm deep GRP solid base sump with watertight flat sealed cover and frame
S2-160	600mm <sup>3</sup> GRP solid base sump with watertight flat sealed cover and frame
S3-176	760mm <sup>2</sup> x 600mm deep GRP solid base sump with watertight flat sealed cover and frame
S4-176	760mm <sup>3</sup> GRP solid base sump with watertight flat sealed cover and frame
S5SB-276	1m <sup>3</sup> GRP solid base sump, corbel and 760mm <sup>2</sup> watertight flat sealed cover and frame
S7SB-276	1.2m <sup>3</sup> GRP solid base sump, corbel and 760mm <sup>2</sup> watertight flat sealed cover and frame
S80- 2760	800mm x 600mm solid base sump, corbel, and 760mm dia. watertight flat sealed cover and frame

### Adjustable Height Systems

#### Product Code Description

S1-3450/SKIRT	450mm <sup>2</sup> x 600mm deep GRP solid base sump with watertight flat sealed cover, frame and skirt
S2-360/SKIRT	600mm <sup>3</sup> GRP solid base sump with watertight flat sealed cover, frame and skirt
S3-376/SKIRT	760mm <sup>2</sup> x 600mm deep GRP solid base sump with watertight flat sealed cover, frame and skirt
S4-376/SKIRT	760mm <sup>3</sup> GRP solid base sump with watertight flat sealed cover, frame and skirt

Note - skirt hangs inside the sump.

### Octagonal Adjustable Height Systems

#### Product Code Description

S60-3180	600mm dia. multi sided GRP solid base sump with a 450mm dia. watertight flat sealed cover frame & skirt (fits 4" and 6" duct)
S75-3600	770mm dia. multi sided GRP solid base sump with a 600mm dia. watertight flat sealed cover frame & skirt (fits 4" and 6" duct)

# Site specific solutions

## Retrofit Tank Connection Systems

Where existing tanks will not be replaced, we can provide a retro-fit connection system. This creates a watertight connection between a Fibrelite tank chamber and the existing tank.

Adaptor systems can be connected to the existing tank upstand or directly to the tank manway lid. Site specific solutions can be supplied. Please contact us for further information.

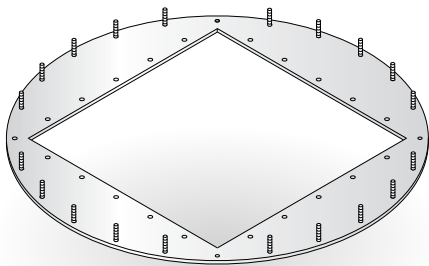

**EMAS/S14/UK**

### Connection to a tank upstand

Product Code	Description
EMAS/S8/UK	Adaptor plate to fit an S8 chamber to a 1m square upstand
EMAS/DIN	Adaptor plate to fit an S8 chamber to a DIN 1m square upstand
EMAS/S14/UK	Adaptor plate to fit an S14 chamber to a 1m square upstand
EMAS/S14/ROUND	Adaptor plate to fit an S14 chamber to a 1.2m dia. upstand

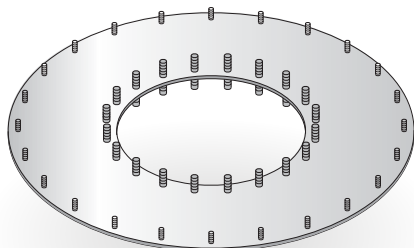

**EMAS1-5**

### Connection to a tank manway lid

Product Code	Description
SPMAS/S5/1-5	Manway lid adaptor plate to fit our S5 and S16SQ chambers
SPMAS/S7/1-5	Manway lid adaptor plate to fit our S7 chamber
SPMAS/S7SB/1-5	Manway lid adaptor plate to fit our S5 & S7 solid base chambers
SPMAS/S8SB/AR/1-5	Adaptor ring to connect an S8 solid base cutout chamber to a manway lid
EMAS/S8/1-5	Manway lid adaptor plate to fit our S8 chamber
EMAS/S14/1-5	Manway lid adaptor plate to fit our S14 chamber

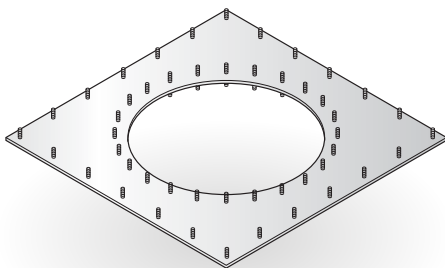

**SPMAS G1-5**

# Complies with APEA/IP guidelines for construction

## Accessories & Maintenance Items

### GRP Sump Extensions

GRP sump extensions can be bonded onto the sump to provide extra height for deep burials. Only one extension can be bonded on to a square sump. On round multi-sided sumps, multiple extensions can be bonded together for deeper burials. Extensions are supplied with bonding sealant.

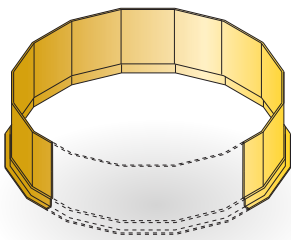

**S8-EX300**

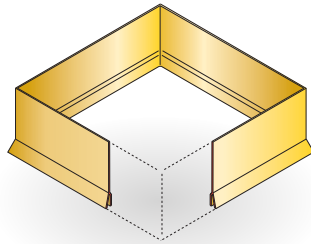

**S7/EX300**

#### Product Code Description

S7/EX300	300mm deep extension to fit S6, S7 and S7SB sumps
S8/EX300	300mm deep extension to fit S8 and S8SB sumps
S14/EX300	300mm deep extension to fit S14 sumps
S15/EX300	300mm deep extension to fit S15CR sumps
S16/EX300	300mm deep extension to fit S16 sumps
S16SQ/EX300	300mm deep extension to fit S16SQ sumps

### GRP Internal Lids & Structural Platforms

Non structural internal lids are supplied as standard with all our sump systems. Structural platforms should be ordered for selective installations, where health and safety dictates that a person must stand on the platform (for checking a dip stick or filling). Structural platforms are designed for a safe working load of 200kg and are coated with a tough anti-slip finish.

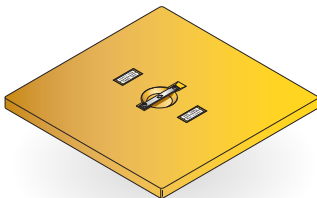

**S/LID/SQUARE**

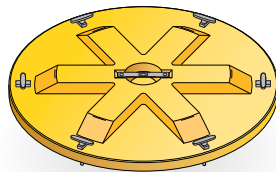

**S/S-LID/ROUND/WT**

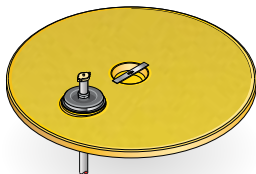

**S/S-LID/ROUND/D-EU**

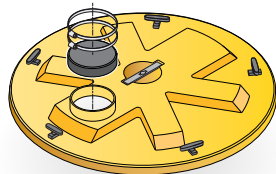

**S/S-LID/ROUND/OD/WT**

#### Non structural internal lids

##### Product Code Description

S/LID/ROUND	Round internal lid to fit systems with the 900mm dia. cover
S/LID/SQUARE	Square internal lid to fit systems with the 760mm square cover
S/LID/ROUND/100	Round internal lid to fit systems with the 1020mm dia. cover

#### Structural Platforms

##### Product Code Description

S/S-LID/SQUARE/20	Square platform with one central hole (200mm dia.) with upward lip. Designed for central manual dip and fill riser.
S/S-LID/SQUARE/SOLID	Solid square platform, 6 hole positions marked to be cut to suit offset manual dip.
S/S-LID/ROUND/20	Round platform with one central hole (200mm dia.) with upward lip. Designed for central manual dip and fill riser.
S/S-LID/ROUND/SOLID	Solid square platform, 6 hole positions marked to be cut to suit offset manual dip.
S/S-LID/ROUND/D-EU	Round solid platform with offset molded sealed port 140mm dia. for manual dip. Pipe sealkit included.
S/S-LID/ROUND/D-EU2	Round solid platform with offset moulded port 140mm dia. for manual dip, complete with hand cap
S/S-LID/ROUND/CDHC	Centre dip structural platform with hand cap.
S/S-LID/ROUND/WT	Round structural platform with gasket and six locking t handles (fits 900mm dia. riser)
S/S-LID/ROUND/OD/WT	Round structural platform with gasket and six locking t handles with an offset dip port (fits 900mm dia. riser)

# First class, reliable after sales service

## High Groundwater Sealkits

Designed to seal between the corbel and skirt of our height adjustable sump systems, the flexible sealant allows for ground movement. This eliminates potential load transfer from the cover to the tank. A water collection bottle and drain is designed to collect any condensation build up inside a sealed system, which collects in the sealed recess and drains into the bottle. The sealant is petroleum resistant

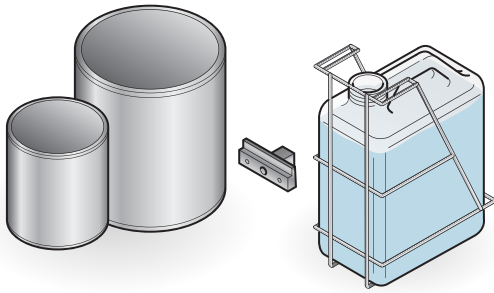

Product Code	Description
S/CS/SEALKIT	Half tin sealant (Tins A & B), bottle, cage, drain & fixing kit
S/CS/SEALANT	1 tin sealant (A), 1 tin catalyst (B)
S/CS/BOTTLE	Bottle, cage, drain and fixings
S/BOTTLE	Bottle only
S/CAGE	Hanging cage for bottle
S/DRAIN	Drain with fixing kit

## Lifting Handles

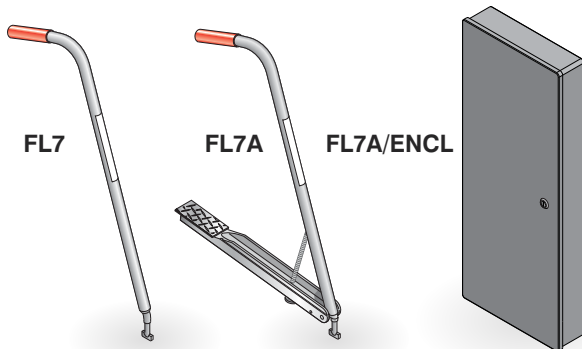

Product Code	Description
FL7	To easily & safely remove & replace raised covers and flat covers with no seal
FL7A	With foot lever designed to break the seal on watertight flat sealed covers. It can be used to remove all types of Fibrelite covers
FL7A/ENCL	910 x 362mm lockable cabinet to house 2 FL7A lifting handles (handles not included)

## Cover/Frame Locks

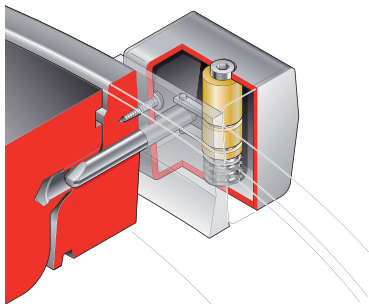

Product Code	Description
FIB/L	Lock to fit FL1, FL3, FL10 covers
FIB/RL	Lock to fit FL12, FL36, FL42 covers
FIB45/L	Lock to fit FL45 cover
FIB76/L	Lock to fit FL450, FL60, FL76, FL900, FL96 & FL140 covers For FL140 two locks are required.
FIB90/L	Lock to fit FL120, FL180, FL600, FL760, FL90 & FL100 covers
FIB2/L	Tamper proof lock to fit all flat sealed cover models

## Sump Collar Ring Bonder Kit

Product Code	Description
BK-800/TUBE	Polymer bonder seals the S8CR & S15CR sump to the tank collar (double tube)
BK/NOZZLE	Mixing nozzle to fit 800 bonder
BK/GUN-P	Pneumatic applicator gun
BK/GUN-M	Manual applicator gun
S/FIBKIT	Fibreglass kit. Includes fibreglass strips, resin & catalyst. Use with S8CR & S15CR systems.

## Replacement Cover Sealkits

Product Code	Description
FL100/SRK	FL100 cover seal replacement kit
FL90/SRK	FL90 cover seal replacement kit
FL760/SRK	FL760 cover seal replacement kit
FL600/SRK	FL600 cover seal replacement kit
FL180/SRK	FL180 cover seal replacement kit
FL120/SRK	FL120 cover seal replacement kit
FL140/SRK	FL140 frame seal replacement kit
FL900/SRK	FL900 frame seal replacement kit
FL96/SRK	FL96 frame seal replacement kit
FL76/SRK	FL76 frame seal replacement kit
FL60/SRK	FL60 frame seal replacement kit
FL450/SRK	FL450 frame seal replacement kit
FC-254/SRK	FC-254 cover seal replacement kit

# Testable containment

## Vacuum Testing

Ten years ago, Fibrelite developed yet another world's first in the petroleum industry - an electronic vacuum testing system to test the containment of underground sumps.

Over the years, interest has steadily increased and it has now been adopted by oil companies worldwide, as the only reliable method to test and verify liquid-tight containment of underground sumps.

Hydro-static (water) testing is a slow laborious process, which frequently does not detect pinhole leaks, which allow groundwater into the system overtime. The Fibrelite vacuum test can detect holes as small as 0.2mm diameter.

The Sherlock system allows stage by stage testing during installation, which would otherwise be impossible to perform. Thus verifying the quality of workmanship throughout.

It is possible to perform an annual retro-test on live sites. This provides maintenance crews with a quick method of leak detection, allowing them to fix any problems without costly site closures.

Either Fibrelite distributors or trained contractors will be nominated by oil companies to perform testing. The contractor will charge for testing on a site by site basis. Testing is conducted until a pass is achieved. The contractor will then issue a dated and signed certificate with detailed information of testing performed on the site. This is the customer's guarantee that sumps have been tested and are verified to be liquid-tight.

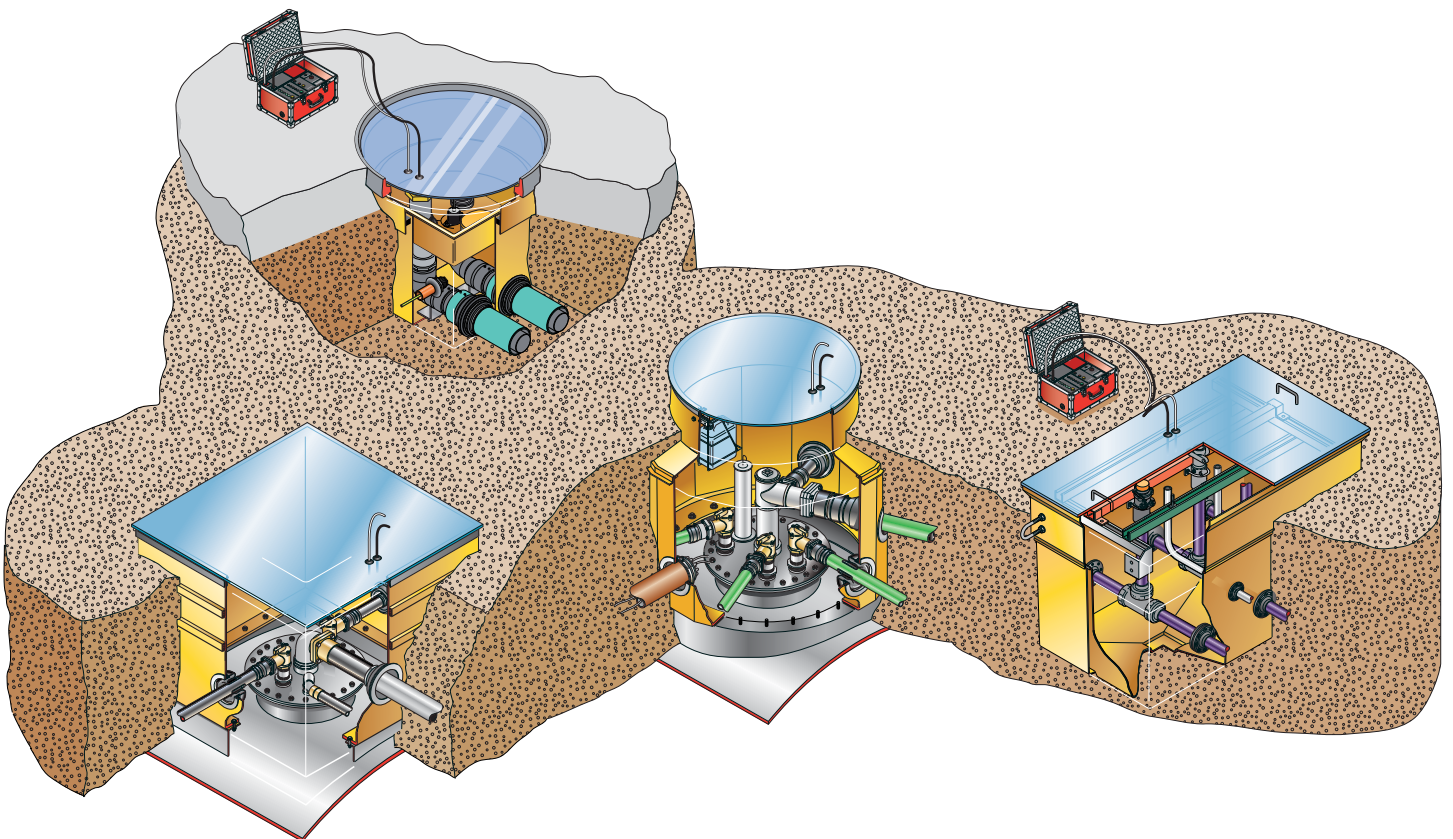

**WARNING:** Fibrelite testing equipment should not be used to test non-Fibrelite sumps, as it may cause structural failure (especially with polyethylene).

# World's first vacuum testing system designed

## Testing Equipment

The Sherlock system comprises of an electronic vacuum testing module and a series of see-through Perspex test plates designed to fit various models of Fibrelite sumps.

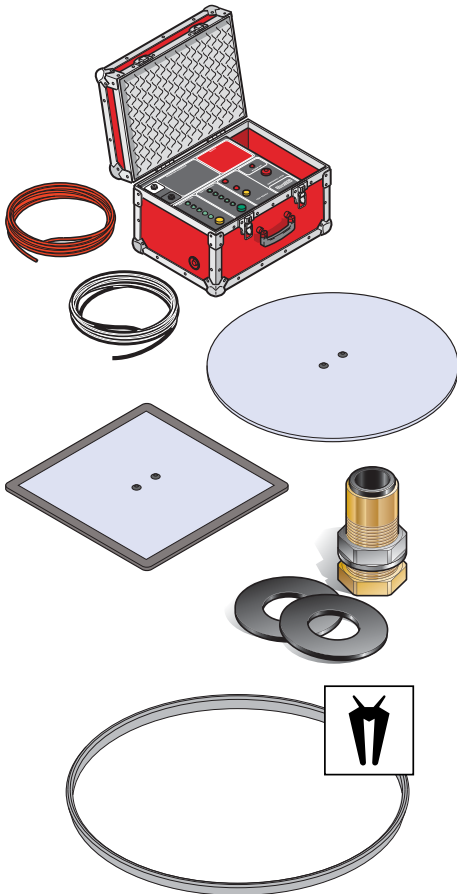

Product Code	Description
VTM/220	220 Volt electronic vacuum test module
VTM/110	110 Volt electronic vacuum test module
CTP/R/S8	Round test plate to fit S8 sumps
CTP/R/S14	Round test plate to fit S14 sumps
CTP/R/S15	Round test plate to fit S15 sump
CTP/R/S16	Round test plate to fit S16 sump
CTP/S/S7	Square test plate to fit S5, S6 & S7 sumps
CTP/R/CORBEL	Round corbel test plate
CTP/R/CORBEL/100	Round corbel test plate for FL100 systems
CTP/S/CORBEL	Square corbel test plate
CTP/FL90	FL90 Frame test plate
CTP/FL760	FL760 Frame test plate
CTP/FL180	FL180 Frame test plate
CTP/FL120	FL120 Frame test plate
CTP/FL76	FL76 Frame test plate
CTP/FL60	FL60 Frame test plate
CTP/BHF/8mm	8mm replacement valve fitting
CTP/S/CORBEL/SEAL	Replacement seal for square corbel test plate
CTP/S/S5/SEAL	Replacement seal for S5 sump test plate
CTP/S/S7/SEAL	Replacement seal for S7 sump test plate
CTP/R/CORBEL/SEAL	Replacement seal for round corbel test plate
CTP/R/CORBEL/100/SEAL	Replacement seal for round 100 corbel test plate
CTP/R/S8/SEAL	Replacement seal for S8 sump test plate
CTP/R/S14/SEAL	Replacement seal for S14 sump test plate
CTP/R/S15/SEAL	Replacement seal for S15 sump test plate
CTP/R/S16/SEAL	Replacement seal for S16 sump test plate

## Testing Tank Sumps

A vacuum test is performed to check the following :

1. The structural integrity of the sump.
2. Joints and bolt hole connections between the sump and tank.
3. The tank manway lid joints and all pipework connections.
4. Sump wall pipework and conduit penetrations and the integrity of entry fittings.

### Stage 1 - Testing the sump

Pipework penetrations through the sump wall are completed and any open connections on the manway lid are capped off. Soapy water is brushed liberally on all joints, pipework and connections and the manway lid. A test plate is then placed on top of the sump and the test begins. It will take about five minutes to pull a vacuum, and a further five minutes to test. A leak will be shown by bubbles, as air is pulled through the hole. All leaks must be fixed and the sump re-tested until a pass is achieved.

### Stage 2 - Testing the sump to corbel joint

A smaller test plate is placed on top of the corbel. This test is designed primarily to test the sealed corbel joint. This also re-tests the sump and all penetrations below (as per stage 1). Once again, the test is performed until a pass is achieved.

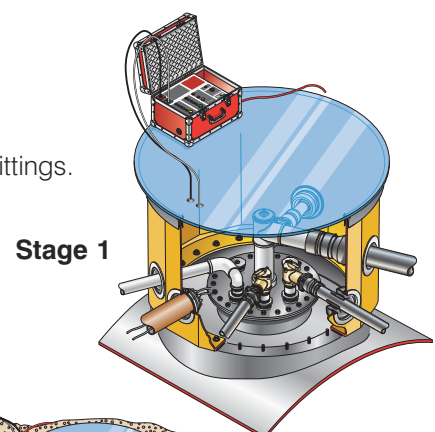

Stage 1

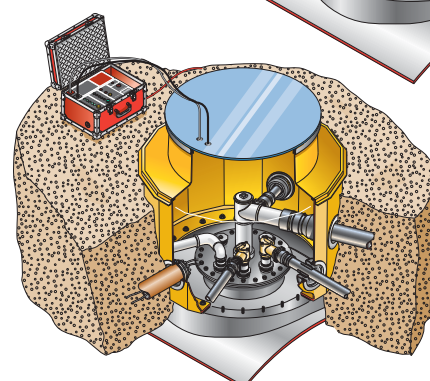

Stage 2

# to verify that sumps are liquid-tight

### Stage 3 - Post concrete final test

After the concrete has cured, a final test can be performed by placing a test plate on the corbel. This will re-test the corbel joint and all penetrations below. An annual retro-test is performed using the same method with additional safety procedures required for live site testing.

### Stage 4 - Post concrete final test on sealed systems

On sealed systems where the space between corbel and skirt has been filled with sealant, an optional test can be performed using a small vacuum. The sealant must be completely set, before testing is performed. This optional test will test the seal, the corbel, all penetrations and joints in the sump below. For this test, a test plate is placed in the frame.

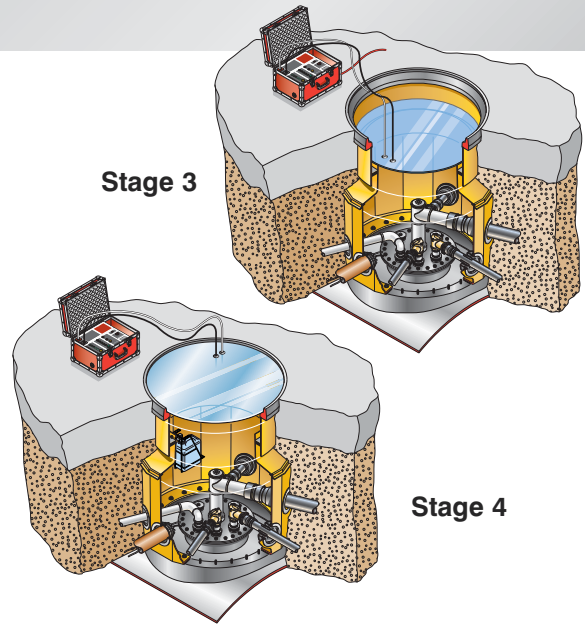

## Dispenser Sump Testing

A hydrostatic (water) test is usually performed on dispenser sumps. Fibrelite offer an alternative vacuum test to speed up the testing process for installers.

After pipework and conduit penetrations through the sump wall have been installed. The upward pipe risers must be capped off below the top level of the sump. A test plate is then placed on the sump and a test is performed.

Contact the Fibrelite Technical department for further information.

## Fill Sump Testing

Fill sump containment has historically been a problematic and costly area on many sites. Spill containers frequently degrade and leak overtime. Fibrelite offer a new containment and testing solution to give customers peace of mind.

### 1. Testing Fibrelite Sumps

Our secondary contained remote and direct fill sumps can be tested at frame level, once all pipework and conduit penetrations are completed as a final test for containment.

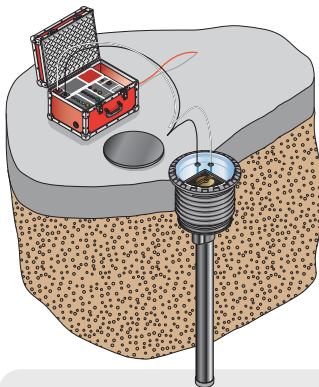

### 2. Testing Non Fibrelite Spill Buckets

Both new and existing spill buckets can be tested with our new range of test plates. Currently we have 12", 13 3/8" and 17" diameter tests plates designed to test most non-Fibrelite spill containers on the market. Only a very small vacuum is used and the test is very quick due to the low volume inside the spill container. This offers a quick and easy way to test a high risk containment area.

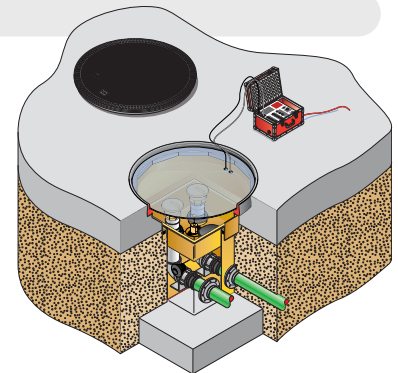

## Other Testing Available

Testing can be performed on all types of Fibrelite sumps - large or small. From ATG sumps, electrical drawpits to large tank sumps.

Please contact Fibrelite for further information about testing products not included in this brochure.

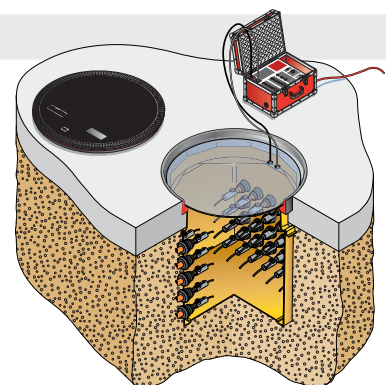

Distributor Contact Details



Fibresec  
GROUP  
COMPANY



FM 37923

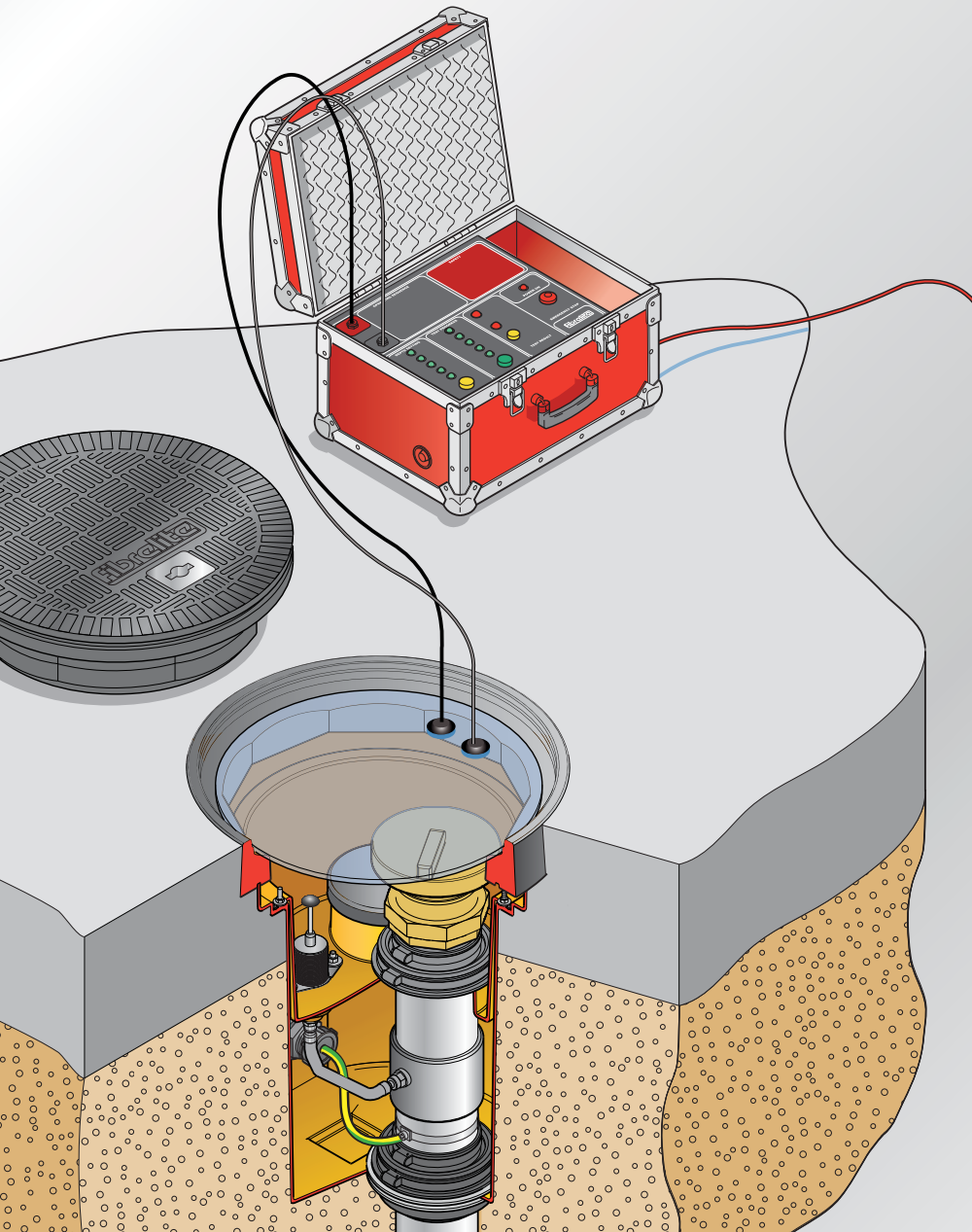

**UK Office:** Snaygill Industrial Estate, Keighley Road, Skipton, North Yorkshire, BD23 2QR, UK  
Tel: +44 (0)1756 799773, Fax: +44 (0)1756 799539, E-mail: covers@fibrelite.com, Website: www.fibrelite.com

**US Office:** 3250 US 70 Business West, Smithfield, NC 27577, USA  
Tel: + 1 800 422 2525 Fax: +1 800 421 3297 E-mail: covers@fibrelite.com

**Asia Office:** Lot 12d, Lrg Tandang B, Sek 51, 46050 Petaling Jaya, Selangor, Malaysia  
Tel: +60 3 7770 1000, Fax: +60 3 7770 1010, E-mail: covers@fibrelite.com