

# Introducing the World's Most Complete, Reliable and All Access-Able All The Time Integrated Underground Fueling System

**The Ultimate Environmental Protection and Cost-Savings Solution** – effectively and affordably meet ever-changing environmental compliance requirements today, tomorrow and into the future

**NEVER  
BREAK  
CONCRETE  
AGAIN**

ONLY BY

**OPW**   
FUELING CONTAINMENT SYSTEMS

A **DOVER**™ COMPANY

**Leading the Way in Underground Fueling System Innovation Worldwide**

# ALL ACCESS-ABLE ALL THE TIME

## – ONLY FROM OPW

### The Problem:

- ◆ **If it's underground it can't be ignored** - Buried joints. Inaccessible pipe. Dumb spill containers. Deep, inaccessible sumps. **All these things equal potential undetected problems.**
- ◆ If the laws change – you'll need to dig it all up and start over. Expensive.

### The Solution:

- ◆ **The OPW All Access-Able All The Time Underground system –**
  - Your entire underground system is **Access-Able, Monitor-Able, Maintain-Able, Repair-Able, Replace-Able** At All Times – without breaking concrete!!
  - This includes primary pipe, fittings, dispenser sumps, spill containers, overfill valves, emergency valves, vents – you don't need a jackhammer to confirm your underground system is working or in compliance
  - Best of all, when the environmental compliance rules change, you will be **"Able"** to upgrade to meet the need quickly and affordably

The  
**EDGE**  
Series

Totally **"Access-Able"** for improved reliability, installation, testing and serviceability



- ◆ Most advanced spill container technology in the industry to meet current and future compliance requirements
- ◆ Completely upgradable, replaceable primary and secondary containers & snow plow rings without breaking concrete
- ◆ Easily **"Access-Able"** test ports (visual & electronic sensors)

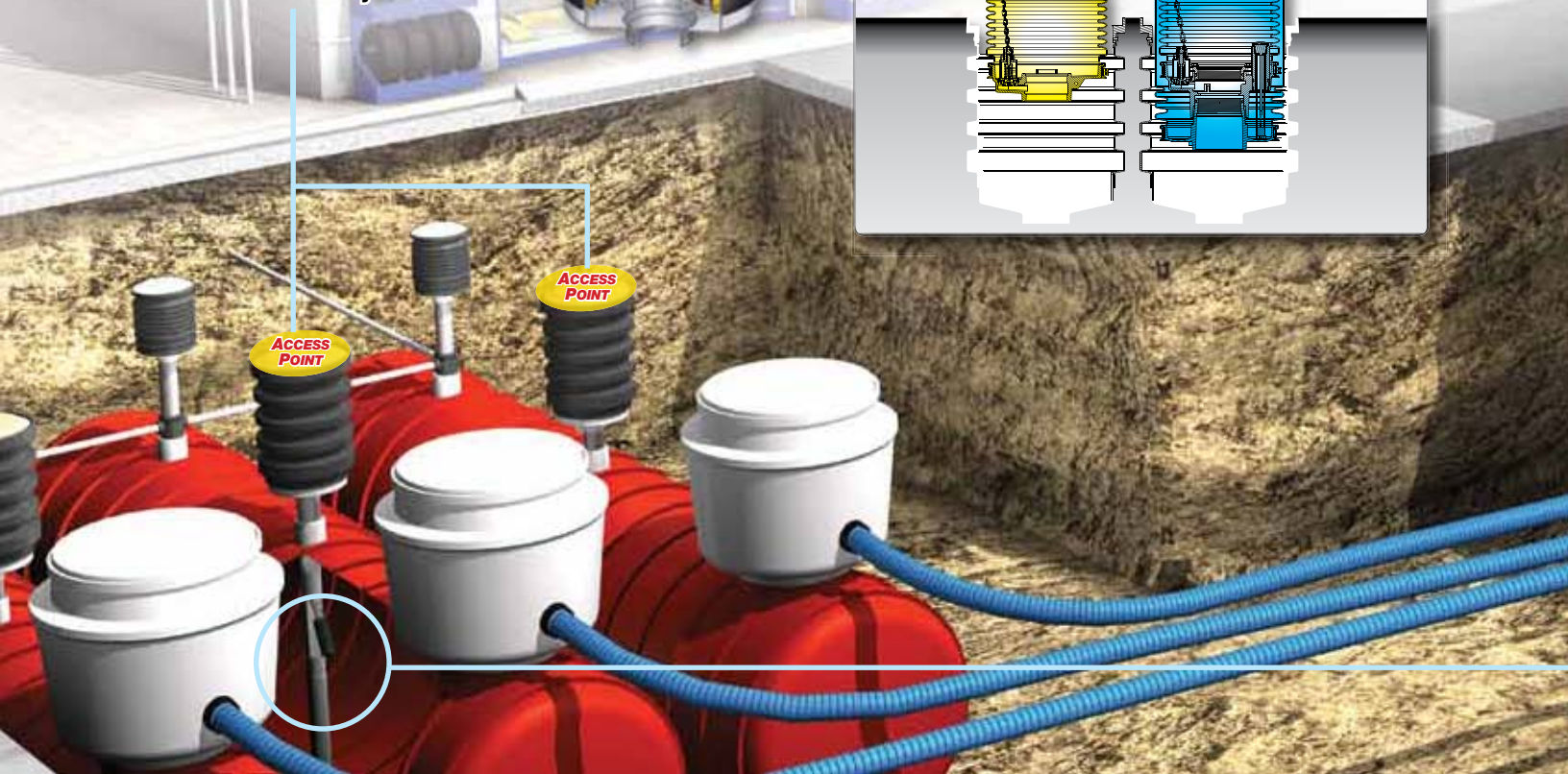
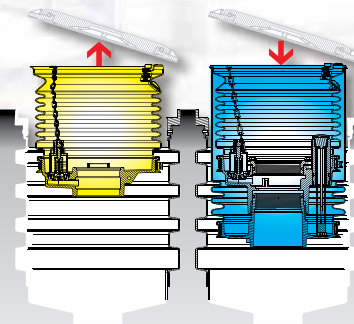

OPW Fueling Containment Systems is **Leading the Way** in underground fuel transfer and containment solutions with the world's only **All Access-Able All The Time** integrated system.

In the ever-evolving world of environmental regulations, you need an underground fuel transfer and containment system **capable** of meeting your compliance needs today that can be adapted quickly, easily and affordably to meet the compliance needs of tomorrow.

# LOOP SYSTEM™

The patented Loop System™ represents state-of-the-art fuel delivery and containment technology in a fully integrated, environmentally secure underground system that employs factory-incorporated, proven innovation, simplified piping

system design, and enhanced leak prevention capability – all while facilitating easy access to under-dispenser components, easy inspection, identification and repairs before a problem may develop.



### Crush-Resistant Access Pipe & Retractable Primary Pipe

- ◆ Fully-bonded, premium PVDF primary pipe construction
- ◆ Complete peace-of-mind protection, performance and installation or replacement ease
- ◆ Improves testing reliability and eliminates the need for rubber



### Double-Flexible Entry Boots

- ◆ Provides double containment protection at the sump/entry fitting connection points to ensure “dry sump” integrity
- ◆ Prevents groundwater intrusion into the sump and eliminates communication so fluid collected in the sump cannot enter the access pipe



### 10 Plus Emergency Valves

- ◆ Easily “Access-Able” under the dispenser
- ◆ Patent-pending technology delivers the highest level of protection and peace-of-mind in the industry against low-impact breaks, dislodged dispensers and dispenser sump fires.



### Prefabricated Quick-Couple Dispenser Sumps

- ◆ Saves time and money – Improves installation reliability
- ◆ Ensures “dry sump” integrity
- ◆ Provides for easy visual inspection, access to, and replacement of under-dispenser components without removal of the dispenser



### 7150 Overfill Prevention Valve

- ◆ Rock-solid vaportight overfill prevention (40 CFR-Compliant)
- ◆ The industry's most reliable overfill prevention protection
- ◆ Easily “Access-Able” and “Replace-Able” from within the spill container

OPW primary pipe has the following listings:



# NOTHING IS AS EASY & ACCESS-ABLE AS THE OPW LOOP SYSTEM™

Compare for yourself. And best of all, once it's installed you have complete access to monitor, maintain and, if necessary, replace the system without breaking concrete. **There is nothing else like it!**



**Plug & Play is  
the Efficient Way...**

- ◆ Out-Of-The-Box Fuel Transfer System
- ◆ Saves Installation Time
- ◆ Reduces Pieces & Parts
- ◆ Reduces Potential Leak Points, Hassles & Errors
- ◆ Saves You Money & Headaches

**OPW is Your  
Single Source for  
40 CFR-Compliant  
Underground  
Storage Tank  
Equipment.**



### 40 CFR 63-Compliant Products

- ◆ Spill Containers
- ◆ Overfill Valves
- ◆ Caps & Adaptors
- ◆ Emergency Vents

### OPW 1-2100 Series Spill Containers

**OPW 7150**  
Series overfill prevention valve  
USA Patent No. 4,986,320;  
5,564,464; 5,174,345;  
5,472,012; 5,850,849



**OPW 623**  
Pressure  
Vacuum Vent



**OPW 634TT- /634LPC**  
Vapor-tight product fill cap



**OPW 615A- Rotatable Swivel Adaptor - Fill Port**

USA Patent No. 5,664,951



**OPW 1711T- /1711LPC**  
Vapor-tight vapor recovery fill cap



**OPW 61VSA- Rotatable Swivel Adaptor - Vapor Port**

USA Patent No. 5,664,951



3250 US Hwy. 70 Business West • Smithfield, NC 27577  
Customer Service: (800) 422-2525 • Fax: (800) 421-3297 • Technical Service: (919) 934-2786

[www.opwglobal.com](http://www.opwglobal.com)