

OPW 61fSTOP-3050 & -305A 3" "THE STOPPER"

The 61fSTOP-3050 is an overfill prevention valve for use with an aboveground storage tank (AST) where product is pumped from a transport vehicle into the AST. The valve is designed to stop the flow of product when the tank is filled to a pre-determined level.

Warning: The 61fStop is designed for tight-fill applications and must only be used with appropriate connections. Failure to properly connect the delivery hose or disconnecting a liquid-filled line will result in an extremely hazardous spill which may result in personal injury, property damage, fire, explosion or water and soil contamination.

Installation

The 61fSTOP-3050 is packaged with a 3" diameter, 5" long pipe nipple that is loosely threaded in the inlet of the valve. A collar for attaching the assembly to a 6" riser is loosely assembled over the 5" long nipple. A special adapter with a crossbar is loosely threaded on the inlet end of the nipple. This nipple may be used on single wall tanks if dimension "B" (see illustration) is between 3" and 6". If "B" dimension is 5"- 6", push nipple down until the adaptor meets the collar. However, the ullage will be affected by the length of dimension "B".

For "B" dimensions greater than 6", a different 3" diameter nipple length will need to be determined. See illustration for determining dimension "C".

Instructions for installations where the 5" long nipple is adequate, simply proceed with the following steps:

1. Remove the special adapter from the inlet of the nipple.
2. Remove the collar and nipple from the inlet of the valve.

CAUTION! Care must be taken to prevent damage to the float AND linkage.

3. Apply a gasoline-resistant sealant to the outlet end of the nipple and install it into the inlet of the valve.
4. Apply a gasoline-resistant sealant to the inlet end of the nipple and thread the adapter in place.
5. Tighten the three (3) set screws in the collar.
6. Stand the valve upright, lift the float and release it to make sure it works freely.
7. Apply a gasoline-resistant sealant to the threads of the 6" fitting in the top of the tank. Slide the valve assembly through the fitting.

8. Thread the collar onto the fitting. The valve is now ready for operation.

Instructions for installations where a longer, 3" diameter nipple (dimension "C") must be used, i.e., a nipple length greater than 5". See illustration for determining length of nipple.

If dimension "B" is greater than 6", proceed with the following steps:

1. Determine dimension "C" (length of 3" diameter nipple) by adding dimension "A" and "B" and subtracting 8": $A+B-8=C$. **Note: "A" dimension must be a minimum of 7".**
2. Cut and thread the new nipple which corresponds to dimension "C".
3. Remove adapter from the inlet of the existing nipple and slide the collar off the nipple.
4. Remove the existing nipple from the valve.
5. Apply a gasoline-resistant sealant to one end of the new nipple and thread it into the inlet of the valve.
6. Apply a liberal amount of grease to the o-ring in the collar and slide the collar onto the nipple with the 6" threaded end toward the valve for a distance of 1¼". Tighten the 3 set screws.
7. Apply a gasoline-resistant sealant to the inlet end of the nipple and thread the adapter in place.
8. Stand the assembly upright, lift the float and release it to make sure it works freely.
9. Apply a gasoline-resistant sealant to the threads of the 6" fitting in the top of the tank and slide the valve assembly through the fitting.
10. Thread the collar onto the fitting. The valve is now ready for operation.

Note: OPW recommends using a drop tube, such as the OPW 61FT Series with all 61fSTOPS.

OPERATING PROCEDURES

CAUTION: READ THESE INSTRUCTIONS CAREFULLY AND COMPLETELY BEFORE OPERATING THIS DEVICE.

The 61fSTOP-3050 "The Stopper" is provided with a special adaptor which requires the appropriate attachment for connection to achieve a tight fit.

CAUTION! OPERATIONS PROCEDURES CONTINUED ON NEXT PAGE.

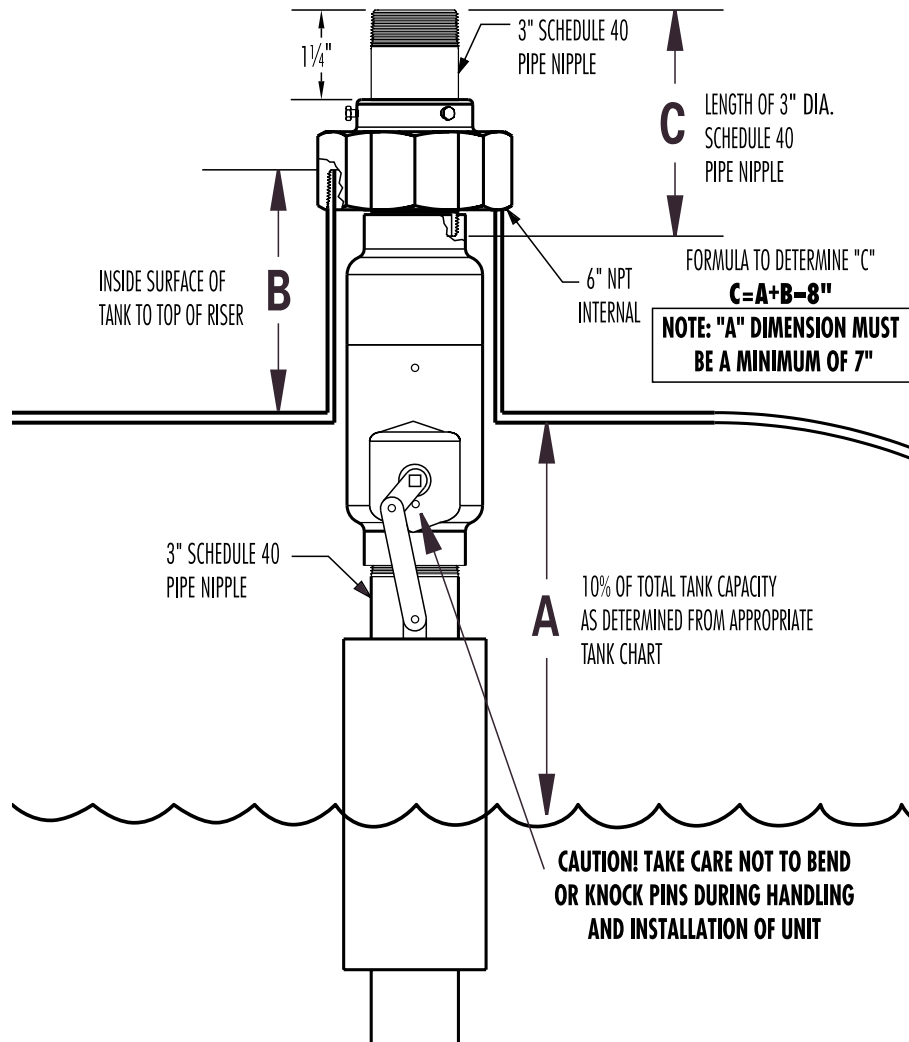

Filling Procedures:

1. Make sure the nozzle is equipped with the appropriate coupler to achieve an adequate connection.
2. Attach the coupler to the adaptor.
3. Turn on the pump.
4. Slowly open the nozzle.
5. Monitor the liquid level gauge during fill.
6. Watch for any quick movement of the hose which indicates that shut-off has occurred.

Disconnection Procedures:

1. After shut-off has occurred, close the nozzle.
2. Turn off the pump at the transport vehicle.
3. Re-open the nozzle and wait approximately 2 minutes. This allows the pressure in the hose to be reduced.

CAUTION! attempting to disconnect the coupler with pressure in the hose will result in the release of product.

4. Close the nozzle and slowly uncouple the connection.
5. Remove the nozzle carefully and replace the cap.



9393 Princeton-Glendale Road
P.O. Box 405003
Cincinnati, Ohio 45240-5003

Ph: (513) 870-3219
Fax: (513) 870-9186

Intn'l Ph: (513) 870-3315
Intn'l Fax: (513) 870-3157