

OPW 66ISU Vacuum-Assist Stage II Vapor Recovery Breakaways

Single use, vapor poppeted Vacuum-Assist Breakaways available. Designed for those who desire single use breakaway protection on vacuum-assist systems. The 66ISU-5100 comes with a vapor poppet which seals the vapor side during separation.

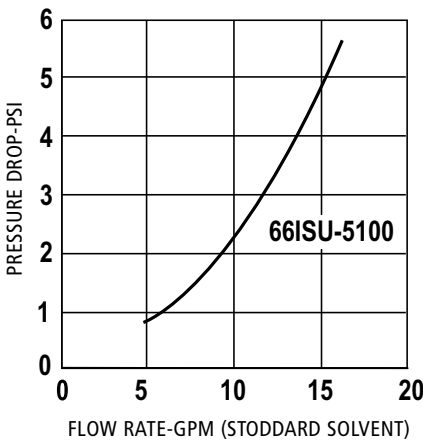

Materials

Body: Aluminum
Main Seals: Viton®
Weight: .53 lbs., 0.24 kg



66ISU-5100

Features

- ◆ UL listed for use in gasoline, diesel and up to 10% ethanol blends. Specific listings available at www.opwglobal.com.
- ◆ Separates at 300 pounds of axial force.
- ◆ Disposable, shear-pin design.

- ◆ Durable, lightweight construction.
- ◆ Minimum vapor pressure drop.

Design working pressure

- ◆ 50 psi (3.45 bar) maximum pressure.

Ordering Specifications

Product #	Threads
66ISU-5100	M34 Metric Breakaway

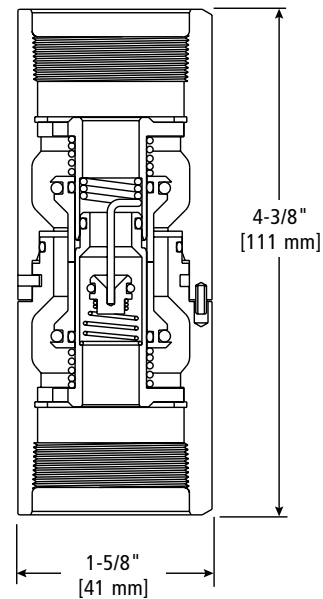

Listings and Certifications



CARB

California Air Resources Board