



Installation and Maintenance Instructions **OPW 199ASV ANTI-SIPHON VALVE**

IMPORTANT: Please read these warnings and assembly instructions completely and carefully before starting. Failure to do so may cause product failure, or result in environmental contamination due to liquid leakage into the soil, creating hazardous spill conditions.

IMPORTANT: Check to make sure the product is intact and undamaged and all parts have been supplied. Never substitute parts for those supplied. Doing so may cause product failure.

WARNING-DANGER: Using electrically operated equipment near gasoline or gasoline vapors may result in a fire or explosion, causing personal injury and property damage. Be sure that the working area is free from such hazards, and always use proper precautions.

NOTE: At all times when product is in the storage tank keep the riser pipe capped, so the vapors can not escape into the environment.

Notice: OPW products must be used in compliance with applicable federal, state, and local laws and regulations. Product selection should be based on physical specifications and limitations and compatibility with the environment and material to be handled. OPW makes no warranty of fitness for a particular use. All illustrations and specifications in this literature are based on the latest production information available at the time of publication. Prices, materials, and specification are subject to change at any time, and models may be discontinued at any time, in either case, without notice or obligation.

Product Warranty

OPW warrants that products sold by it are free from defects in materials and workmanship for a period of one year from the date of shipment by OPW. As the exclusive remedy under this limited warranty, OPW, will at its sole discretion, repair, replace, or issue credit for future orders for any product that may prove defective within the one year period. This warranty shall not apply to any product that has been altered in any way, which has been repaired by any party other than a service representative authorized by OPW, or when failure is due to misuse, conditions of use, or improper installation or maintenance. OPW shall in no instance have any liability whatsoever for special, incidental or consequential damages to any party and shall have no liability for the cost of labor, freight, excavation, clean up, downtime, removal, reinstallation, loss of profit, or any other cost or charges in excess of the amount of the original invoice for the products.

THIS WARRANTY IS IN LIEU OF ALL OTHER WARRANTIES, EXPRESS OR IMPLIED, AND SPECIFICALLY THE WARRANTIES OF MERCHANTABILITY AND FITNESS FOR A PARTICULAR PURPOSE. THERE ARE NO WARRANTIES WHICH EXTEND BEYOND THE DESCRIPTION ON THE FACE HEREOF.

199ASV ANTI-SIPHON Performance Specifications:

This OPW Anti-Siphon valve is designed to help prevent siphoning of an aboveground storage tank should a leak or break occur in the fuel supply line.

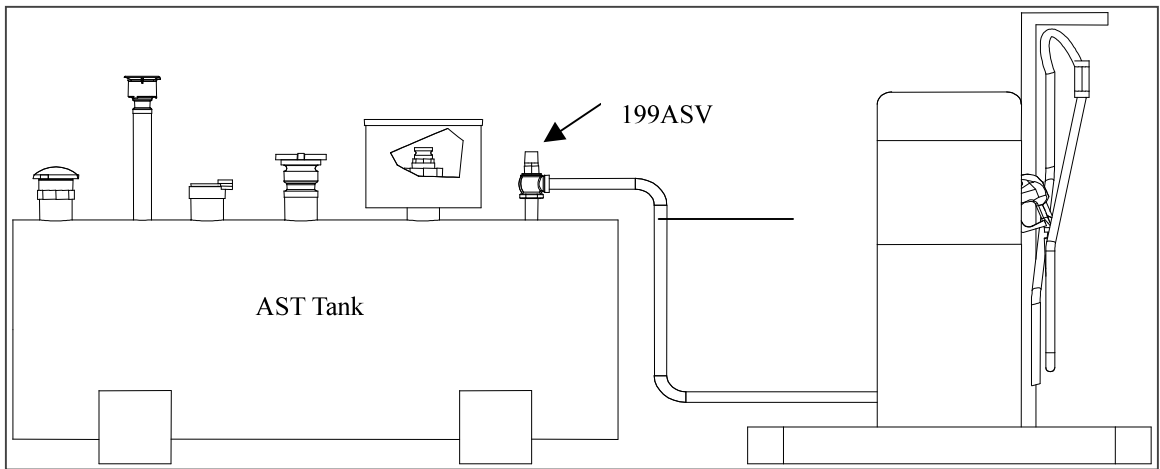
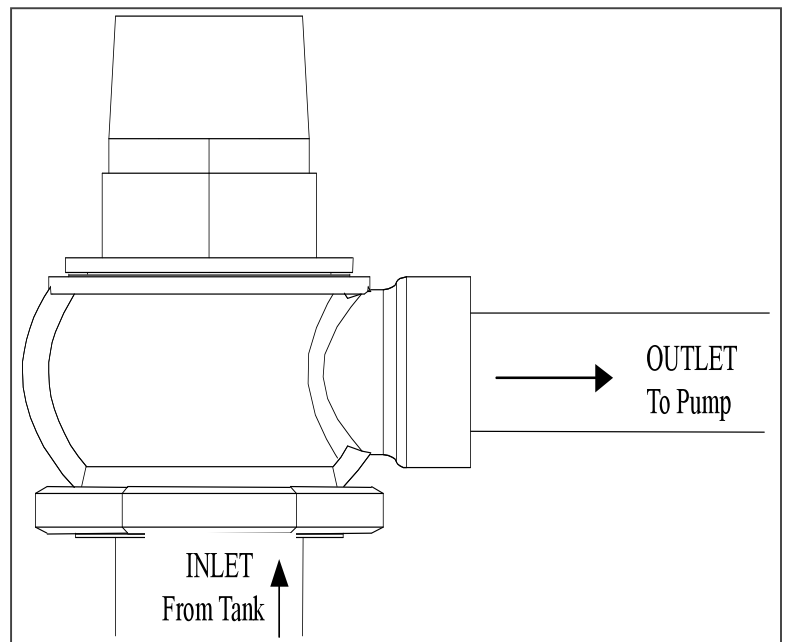

Figure 1

Installation Instructions:

1. Install the 199ASV as shown in Figure 1.
2. Apply a gasoline resistant pipe dope to the threads of the Inlet & Outlet of the 199ASV

Note: The OPW 199ASV contains no adjustable, replaceable, or repairable parts. DO NOT disassemble.



OPW®

FUELING COMPONENTS

A TOVER RESOURCES COMPANY

P.O. Box 405003 • Cincinnati, Ohio 45240-5003

(513)870-3219 • (800)422-2525 (Orders Only)

(513)870-3100 (Other Calls)



