

OPW®

Field Installation Instructions for OPW Hand Insulators

1. *This Installation May Be Performed Without Removing The Nozzle From The Hose.*
2. *Cut New Hand Insulator At rear, Between Holes.(Per Fig. 1)*
3. *Remove Old Hand Insulator.*
4. *Install New Hand Insulator.*
5. *Insert Tie Through Rear Holes.(Per Fig. 2)*
6. *Insert Tie End Through Slot - Pull Snug By Hand.*
7. *Cut Excess Tie Off.*

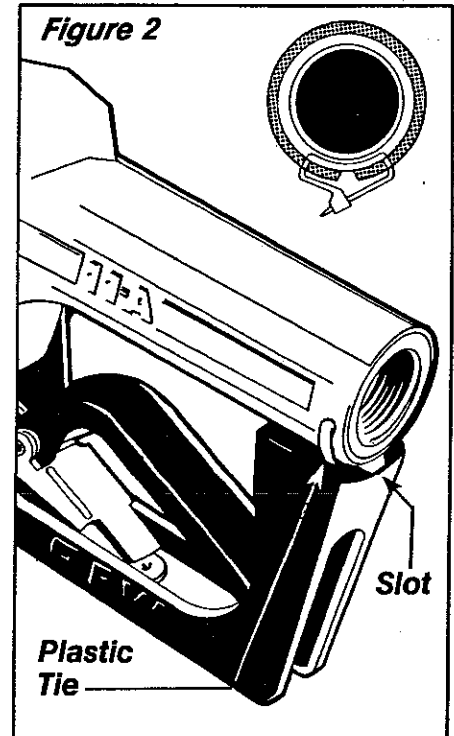
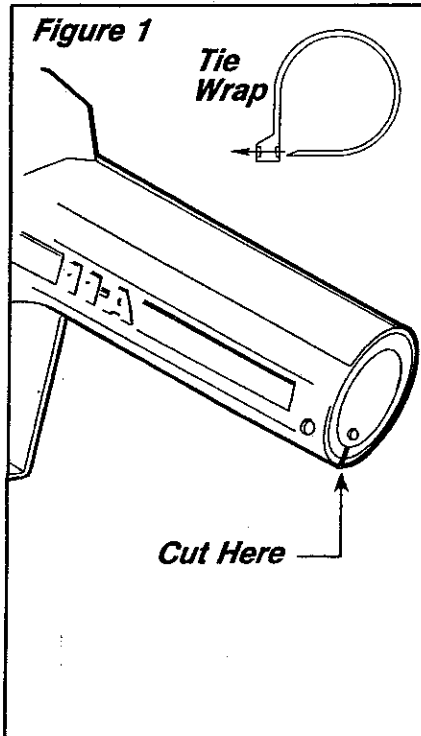

OPW®

FUELING COMPONENTS

A DOVER RESOURCES COMPANY
P.O. Box 405003 • Cincinnati, Ohio 45240-5003
(513)870-3219 • (800)422-2525 (Orders Only)
(513)870-3100 (Other Calls)



H-10652-PA
JAN., 1986



ONE COMPANY. ONE WORLD. ONE SOURCE.



OPW TERMS & POLICIES

Notice: OPW/PISCES by OPW Inc. products must be used in compliance with applicable federal, state, provincial, and local laws and regulations. Product selection should be based on physical specifications and limitations and compatibility with the environment and material to be handled. OPW/PISCES by OPW Inc. makes no warranty of fitness for a particular use. All illustrations and specifications in this literature are based on the latest production information available at the time of publication. Prices, materials, and specifications are subject to change at any time, and models may be discontinued at any time, in either case, without notice or obligation.

OPW STANDARD PRODUCT WARRANTY

OPW/PISCES by OPW Inc. warrants that products sold by it are free from defects in materials and workmanship for a period of one year from the date of manufacture by OPW/PISCES by OPW Inc. (ECO systems two years from date of manufacture. ECO replacement parts one year from the date of manufacture.) Proof of purchase may be required. For any product certified to California 2001 standards*, OPW/PISCES by OPW Inc. warrants that products sold by it are free from defects in material and workmanship for a period of one year from date of manufacture or one year from date of registration of installation not to exceed 15 months from date of manufacture by OPW/PISCES by OPW Inc. As the exclusive remedy under this limited warranty, OPW/PISCES by OPW Inc. will at its sole discretion, repair, replace, or issue credit for future orders for any product that may prove defective within the one year date of manufacture period (repairs, replacements, or credits may be subject to prorated warranty for remainder of the original warranty period, complete proper warranty claim documentation required.)

PISCES by OPW, Inc. further guarantees that all PISCES primary pipe is free from defects in materials and workmanship for a period of ten (10) years from the date of manufacture. Any PISCES primary pipe proven to be Defective in materials or workmanship within said 10-year period will, at PISCES option, be repaired or replaced, or credit will be given for future orders. PISCES will bear the reasonable labor costs associated with the repair or replacement of non-conforming PISCES primary pipe when such pipe has been used exclusively in a complete PISCES Retractable System. Any defect will be corrected promptly upon written notification to PISCES by OPW, Inc. at P.O. Box 405003 Cincinnati, Ohio 45240, attention Rick Jones.

This warranty shall not apply to any product that has been altered in any way, which has been repaired by any other than a service representative authorized by OPW/PISCES by OPW Inc. or when failure is due to misuse, improper installation or maintenance. OPW/PISCES by OPW Inc. shall have no liability whatsoever for special, incidental, or consequential damages to any party, and shall have no liability for the cost of labor, freight, excavation, clean-up, downtime, removal, reinstallation, loss of profit, or any other cost or charges.

***Products certified to the California 2001 standards will have an OPW registration card enclosed/attached to the product.**

THIS WARRANTY IS IN LIEU OF ALL OTHER WARRANTIES, EXPRESSED OR IMPLIED, AND SPECIFICALLY THE WARRANTIES OF MERCHANTABILITY AND FITNESS FOR A PARTICULAR PURPOSE. THERE ARE NO WARRANTIES WHICH EXTEND BEYOND THE DESCRIPTION ON THE FACE HEREOF.

CUSTOMER SERVICE DEPARTMENT

North America Toll Free - TELEPHONE: (800) 422-2525 or FAX (800) 421-3297
Email: domesticsales@opw-fc.com
www.opw-fc.com