

## OPW EDGE 1™ Single-Wall Spill-Container

Introducing an advanced single-wall spill-container – the new EDGE 1™ by OPW. The new EDGE 1™ is rugged, easier to install and service, upgrades to a double-wall and is more reliable than current single-wall spill-containers available today. Leading-EDGE design features and superior materials of construction combine with expert spill-containment engineering excellence to deliver more benefits than any other single-wall spill-container, making the EDGE 1™ number one in:

- ◆ Installation and upgradeability ease
- ◆ Serviceability ease
- ◆ Durability and long-life reliability

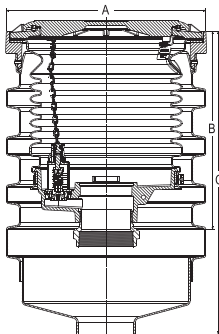

A = 16 5/8"  
B = 16 15/32"  
C = 25 1/4"

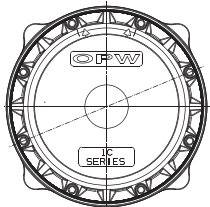

### Replacement Parts/Accessories

Part #	Description
201689	Mounting Ring Seal
201530	Snow-Plow Ring
201692	O-Ring, Nipple Adaptor
1-21CC	Cover
203035	Sealable Cover Ring
H12229M	Cover Seal
SC-xxxx	(Xxxx=Color) Sealable Cover
1DK-2100-EVR	Drain-Valve Sub Assembly
203193-KIT	Replacement 5-Gallon with Drain-Valve
203194-KIT	Replacement 5-Gallon with Drain Plug
IP-2105	Hand Pump

### Materials

- Cover:** Cast iron
- Mounting Ring:** Duragard®-coated ductile iron
- Bellows:** Polyethylene
- Base:** Cast iron E-coating
- Clamps:** Stainless-steel
- Seals:** Buna-N

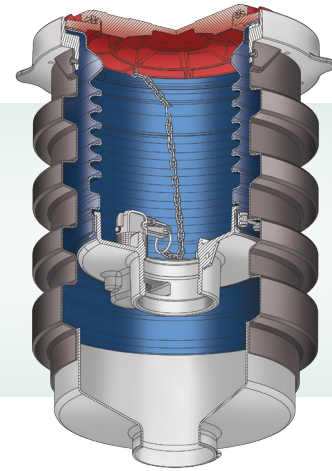

### Features

- ◆ Upgradeable to a double-wall bucket without breaking concrete
- ◆ Quick, easy replacement of spill bucket and mounting ring without breaking concrete – significantly reduces labor time and cost
- ◆ High-quality materials of construction
  - Roto-molded technology - provides for thicker, more robust bellows
  - Heavy-duty ductile-iron mounting ring - provides superior long-term reliability and damage protection against traffic drive-over and snow-plows
  - The integral pull-to-open drain valve uses non-corrosive and stainless-steel materials, unlike our competitors, which have corrosive materials in their design (a drain plug version is also available)
- ◆ Thread-on bucket design - ensures leak-free integrity, especially in the event of ground movement
- ◆ Corrosion-resistant polyethylene skirt – increased rigidity and durability, superior reliability over corrosive metallic skirts
- ◆ Unique concrete anchoring ring – wide-lip and four (4) convenient anchoring ears provide for better anchoring and longevity

### Ordering Specifications

Model #	Description	Weight	
		lbs.	kg
1C-3101D	The EDGE 1™ SW Spill-Container, 5 Gallon capacity, with Cast-Iron Cover and Drain-Valve	117	53
1C-3101P	The EDGE 1™ SW Spill-Container, 5 Gallon capacity, with Cast-Iron Cover and Drain Plug	117	53

**NOTE:** Any model can be purchased with a sealable cover option by using part number 1SC-XXXXD or 1SC-XXXXP.

**NOTE:** FSA-400-S must be installed with the EDGE 1™ to be upgraded to a double-wall spill bucket.

Add the following to part number for colored powder-coated covers and rings. Example 1C-3XXXD-W

<input type="checkbox"/> White	-W	<input type="checkbox"/> Orange	-O	<input type="checkbox"/> Yellow	-Y
<input type="checkbox"/> Red	-R	<input type="checkbox"/> Blue	-B	<input type="checkbox"/> Bronze	-BZ

### Installation Tool

Model #	Description
61SA-TOOL	Wrench for Installation of the EDGE 1™ SW Spill-Container

### Listings and Certifications

**CARB**  
California Air Resources Board

