

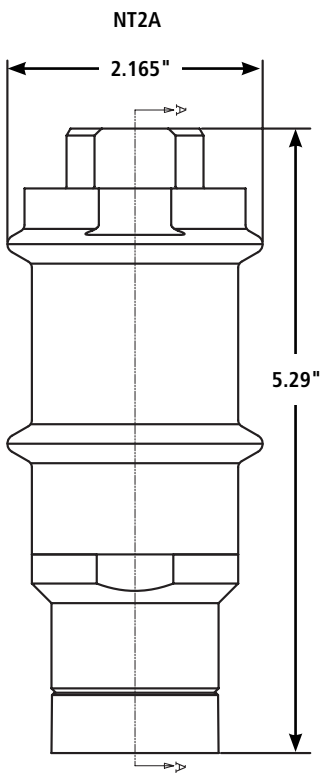

## NT2A Series General Purpose Nozzles (NGV1 & ISO14469, Type 2 or 3)

The NEW NT2A Series nozzle is designed to be versatile for all of your Type-2 CNG fueling applications. The NT2A has true Class-A specified durability and will optimize your time-fill, fast-fill and fleet fueling sites. The ergonomic design, positive locking jaws and best in class internal seals will make this nozzle the preferred choice of your operators.



### Materials

- Body:** Brass
- Jaws:** Stainless steel
- Seals:** Specially formulated polymers and elastomers specific to high pressure NGV applications.



### Features

- ◆ **User-Friendly Push-On/Pull-Off Operation** - For smooth, simple engaging and disengaging of nozzle and receptacle without the added step of pulling back a collar. The NT2A is designed to remain securely connected to the receptacle until the nozzle is depressurized after fueling is complete.
- ◆ **Type** - Designed as a Type 2 or 3 nozzle.
- ◆ **Jaw-Lock Technology** - Designed specifically for the frequent coupling and uncoupling of the high-pressure gas connections of NGV fueling. Forces at the contact point are distributed over the entire surface area of the receptacle.
- ◆ **Ergonomic Design** - Has a comfortable specially designed Duratuff sleeve. Also incorporates stainless steel front sleeve for those hard to reach receptacles.
- ◆ **Durable Construction** - Brass & Stainless Steel construction provides excellent corrosion resistance in the harsh refueling environment.
- ◆ **Safe Disconnect** - Accidental disconnection under pressure is very difficult due to our unique force multiplier design.
- ◆ **Meets NGV1 and ISO14469 Fueling Standard** - Can be used to fuel any vehicle with approved profile receptacle.

### Specifications:

Min. Flow Rate: 1200 SCFM @ 3000 psid  
 Temperature Range: -40° F to 185° F  
 (-40° C to 85° C)  
 Cv: 0.84  
 MAWP: 4532 psi (312.5 Bar)

### Ordering Specifications

Product #	Inlet Thread Size	Color	Service Pressure	Weight.
NT2AP30	SAE - 6, 9/16" - 18 UNF	Blue	NGV1 P30 ISO14469 B200 3000 psi (200 bar)	1.30 lb. 0.59 kg
NT2AP36	SAE - 6, 9/16" - 18 UNF	Yellow	NGV1 P36 ISO14469 B200 36000 psi (250 bar)	1.30 lb. 0.59 kg

Connects to any L-Series-NGV-1 CNG Receptacle

### Listings and Certifications



**NGV1  
ISO14469**