

FlexWorks Polyethylene Dispenser Pans

FlexWorks Dispenser Pans are installed beneath fuel dispensers to provide secondary containment of dispenser plumbing and emergency shear valves. Dispenser pans are commonly used with rigid fuel pipe and to retrofit existing dispensers.

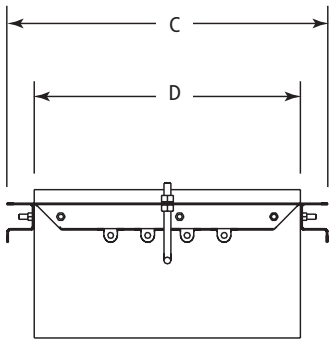
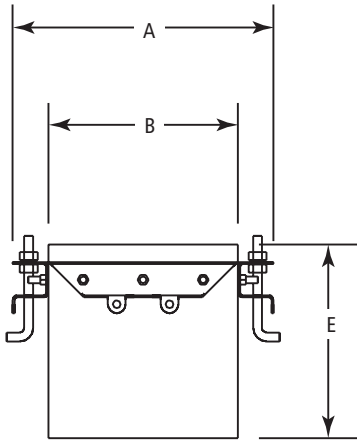

Ordering Specifications FlexWorks Polyethylene Dispenser Pan

Model *	Dimensions										Weight	
	A		B		C		D		E		lbs.	kg
	in.	cm	in.	cm	in.	cm	in.	cm	in.	cm		
DP-1117F	14½	37	10½	27	20½	52	16½	42	11	28	20	9
DP-1123	15	38	11	28	27	69	23	58	11	28	23	10
DP-1123F	15	38	11	28	27	69	23	58	11	28	23	10
DP-1543	19	48	15	38	43	109	38.8	99	11	28	44	20
DP-1630	20	51	16	41	34	86	30	76	11	28	38	17
DP-1836	21½	55	17½	44	40	102	36	91	11	28	50	23

*Flush Mount Model (F) Supplied without Rain Lip Due to Dispenser Frame Clearance Limitations; Supplied with Frame Gasket. Anchor Bolts Provided, Stabilizer Bar Kits Ordered Separately; One Kit Required for each Emergency Shut-Off Valve.