

## OPW 1SC-3112D EDGE™ Double-Wall Sealable Cover Spill Container

Designed in collaboration with contractors and end-users for ease of installation and testability, the OPW 1SC-3112D EDGE installs in the same space as single-wall buckets. The manholes are designed to prevent spilled product from entering the soil during normal tank filling operation or in the event of tank overflow. The operation of the sealable cover is similar to that of a "plumbers plug." When the lever is latched down, the plates are drawn together, expanding the seal against the machined mounting ring wall.

- ◆ Fully testable
- ◆ Sealable cover
- ◆ Watertight design
- ◆ Unbeatable installation ease
- ◆ Uses existing riser pipe

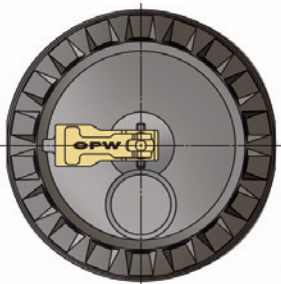

**Watertight Sealable Cover**

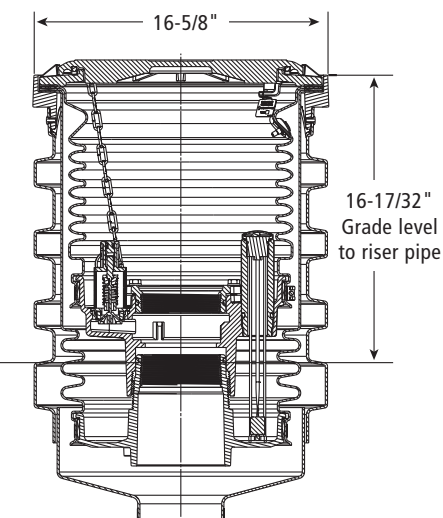

Weight: 120 lbs. (54.5 kg.)

## Materials

- Cover:** Aluminum
- Mounting Ring:** Duragard® coated ductile iron
- Bellows:** Polyethylene
- Base:** Cast iron E-coating
- Clamps:** Stainless steel
- Seals:** Buna-N

## Features

- ◆ **Watertight Sealable Cover**
- ◆ **Compliant with New EPA Requirements**
  - 40 CFR Parts 280 and 281
- ◆ **Top Mounted Vacuum Test Port**
  - For quick and easy access
- ◆ **Superior Visual Gauge**
  - No messy dipsticks to contend with
  - Significantly simplifies and reduces testing time
- ◆ **Ease of Access to the Electronic Sensor for Testing**
  - Easy access for testing
  - Located to eliminate damage potential during product drops
- ◆ **Roto-Molded Primary & Secondary Buckets**
  - Thicker walls for greater durability and reliability
- ◆ **Ribbed Polyethylene Skirt Design**
  - Roto-molded for long-life durability
  - Provides rigidity for added durability
  - Provides handles on all sides for ease of installation
- ◆ **Patent-Pending Socket Design**
  - Enables the EDGE™ to install into the space of a single-wall spill container
  - Helps to align bucket on riser
- ◆ **Patent-Pending Ledge Design**
  - Provides machined sealing face for drop tube
  - Improves overall drop tube sealing integrity
  - Eliminates face seal adaptors or de-burring of the riser pipe to obtain a flat surface for the drop tube
- ◆ **Patent-Pending Removable Adaptor**
  - Allows for quick and easy access to drop tube
  - Eliminates the need for cumbersome chain wrenches
- ◆ **Bellow Seals**
  - Improves overall sealing integrity
  - Eliminates mess and curing time found in sealants
  - Reduces service time and costs

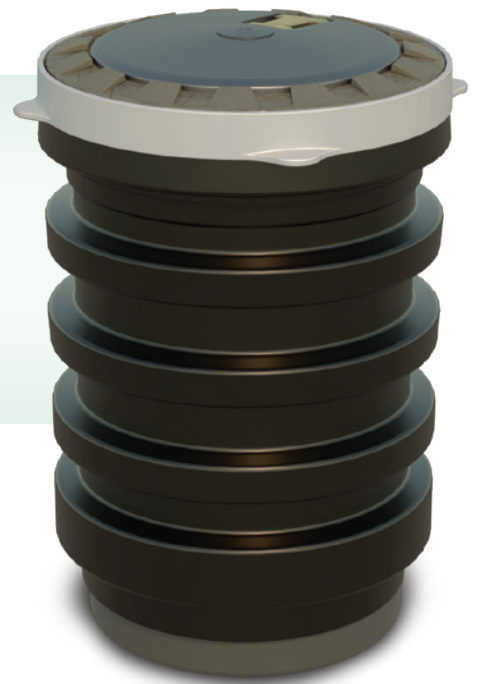

## Listings and Certifications

