

Materials

- Shear pin: Carbon graphite
- Link: Stainless steel
- Bar: Cast iron
- Lid and body: Aluminum
- Sealing surface: Teflon®-coated aluminum

202F SCFH @ 2 1/2 PSI
(0.17 bar)
8" 560,000 SCFH

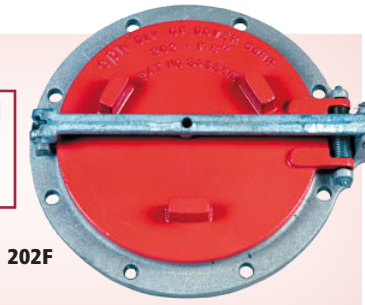

202F

Features

- ◆ **Lightweight Construction** – allows for safe, easy installation on large aboveground tanks
- ◆ **Spring-Loaded, O-Ring Sealed Cover with Teflon®-Coated Seat** – ensures smooth, vapor-tight sealing surface and reliable service life
- ◆ **Full-Bore, High-Capacity Upward Venting** – enables smaller-diameter vents, with higher venting capacity, to be used on ASTs when compared to weighted, mushroom-style vents
- ◆ **Aluminum Cover and Body with Stainless-Steel Components** – corrosion-resistant construction to protect expensive finish or epoxy coatings on ASTs
- ◆ **Alerts Tank Operators of Possible Venting Problems** – when the emergency vent is actuated, the lid remains open for inspection until manually reset. The actuation of the emergency vent indicates abnormal excessive pressure build-up in the tank due to either a blockage in the normal tank vent or in the event of a rapid expansion of vapors possibly from a fire
- ◆ **3-Point Vent Shear System** – Ensures the vent safely opens every time, even if non-OPW replacement parts are utilized. Shear Pin breaks at 2.5 psi (0.17 bar), Break Link breaks at 3.5 psi (0.24 bar), and Bar breaks at 6.5 psi (0.44 bar).
- ◆ **UL-Listed** – to satisfy third-party accreditation requirements of many jurisdictions



Ordering Specifications

Model #	in.	mm	lbs.	kg
202F-0600	8	203	5.2	2.4

Dimensions 202F

Description	in.	mm
A - Flange Hgt.	13/32	10
B - Hole Dia.	7/16	11
C - No. of Holes	8	203
D - Bolt Circle	9 1/2	241
E - Flange Dia.	10 3/8	264
F - Height	12 9/32	311
G - CL of Pivot Pt.	6 3/32	155

202F Replacement Parts

Key	Part #	Description
1	H04869RE	Break Link
2	H06475RE	Rivet
3	H04981M	Cotter Pin
4	H04928	Parts S/A
5	H04929M	Screw
6	C01288I	Bar
7	H04871M	Break Pin
8	C01289M	Gasket
9	H04873M	O-Ring
10	H06449RE	Rivet

**OPW 202F
Emergency Vents**

The OPW 202F Emergency Vent is designed to prevent an aboveground storage tank from becoming over-pressurized by providing full-bore, high-capacity venting in the event of a fire or blockage of the OPW 23, 113, 523V or 623V. The 202F is a vapor-tight, spring-loaded emergency vent. When the AST builds pressure to 2.5 psi (0.17 bar), a break-pin shears and the spring-loaded lid opens full-bore and discharges vapors upward to relieve the pressure. The lid remains open for inspection, to indicate a problem with the normal tank venting or if a fire has taken place, until manually reset. The appropriate 202F Series vent is determined by the emergency venting capacity requirements of the AST and the type of connection at the tank's emergency vent opening. The OPW 202F Emergency Vent is available in an 8" flanged connection to mount directly to a tank manway.

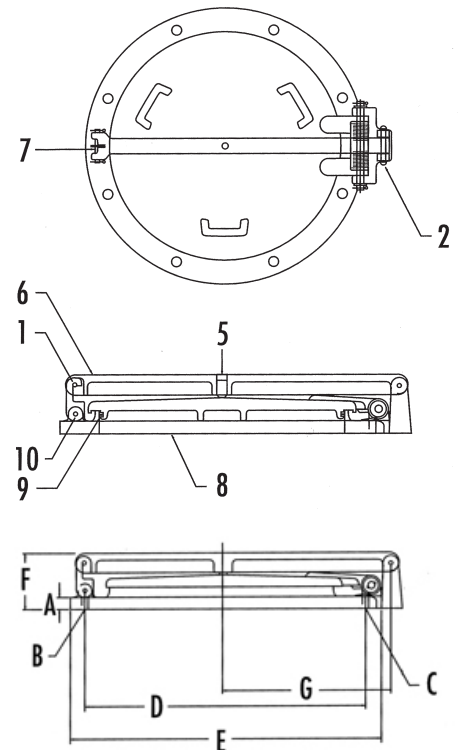

Important

FlexWorks by OPW, Inc., VAPORSAVER™ and all other OPW products must be used in compliance with all applicable federal, state, provincial and local laws, rules and regulations. Product selection must be based on physical specifications and limitations, compatibility with the environment and material to be handled. All illustrations and specifications in this literature are based on the latest production information available at the time of publication. Prices, materials and specifications are subject to change at any time, and models may be discontinued at any time, in either case, without notice or obligation. OPW warrants solely to its customer that the following products sold by OPW will be free from defects in materials and workmanship under normal use and conditions for the periods indicated.