

Special Application Sumps & Extensions

FlexWorks Special Application Sumps are installed below-grade and provide a convenient means of housing a multitude of underground piping connections and equipment, including valves, filters, meters and pumps. The PSL-3830 Line Connection Sump has large horizontal flats to accommodate multiple piping entries. The PSL-3630 Tall Mini-Sump has long vertical flats to accommodate applications with varying pipe entry heights. The PSL-2430 Mini Sump is ideal for connecting long pipe runs in a contained area.

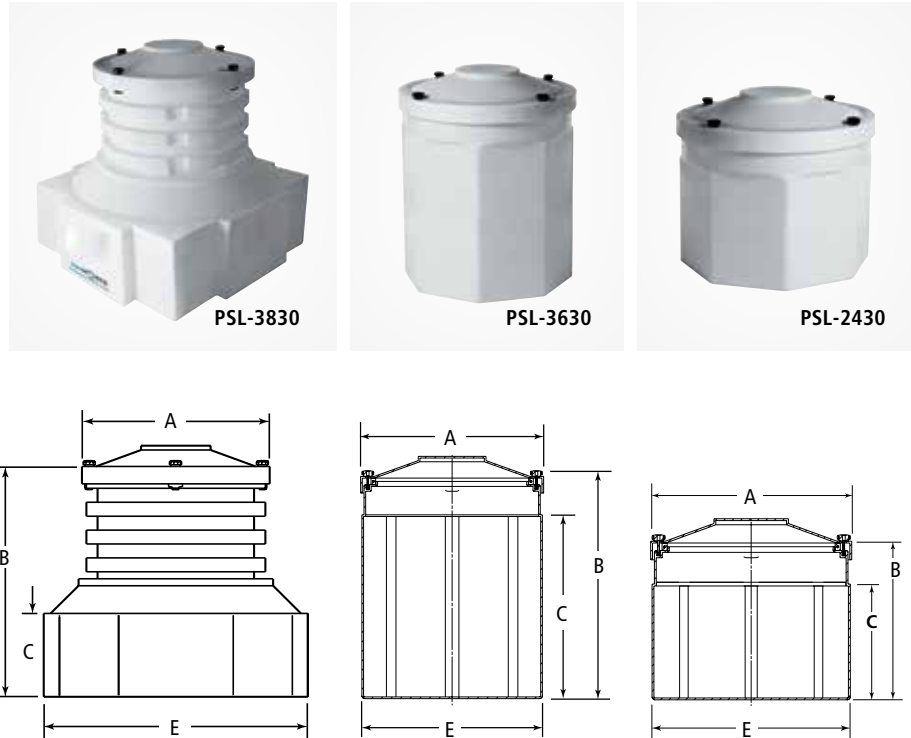

Ordering Specifications - Polyethylene Tank Sumps (with Compression Fit Covers)

Model #	Application	Dimensions								Burial Depth				Weight				
		Manway Dia.		A Cover		B Height		Dimesions CXE		# of Panels	E Base		max.		min.		lbs.	kg
		in.	mm	in.	mm	in.	mm	in.	mm		in.	mm	in.	mm	in.	mm		
PSL-2430	Special Application Sump, 24" x 30"	30	762	27	686	24	914	16 x 10	406 x 254	8	26	660	36	914	26	660	36	16
PSL-3830	In-Line Sump, 38" x 30"	30	762	27	686	63	914	12 x 38	305 x 965	12	38	965	41	1041	29	737	85	38
PSL-3630	Special Application Sump, 36" x 30"	30	762	27	686	36	914	28 x 20	711 x 254	8	26	660	48	1219	40	1016	42	19

Ordering Specifications - New Latched Fiberglass Tank Sump Lids

Part #	Description
CLC-33	Latched Fiberglass Tank Sump Lid
LRK-CLC	Latch Replacement Kit for the CLC-33

Replacement Parts & Accessories

Part #	Description
H13257M	Knob (each)
H13971M	Knob Kit (6 Pack)
H13213M	Bracket
H13214M	Seal 33" (838 mm)
H13215M	Seal 39" (991 mm)
C04420M	Ring 33" (838 mm)
C04432M	Ring 39" (991 mm)
D02025M	Cover 33" (838 mm)
D02034M	Cover 39" (991 mm)
CLC-33	Latched Fiberglass Tank Sump Lid