

**Materials**

**Body:** Cast iron with black Duragard® E-coating

**Discs:** M-19 Viton®

60VP-1001



**Features**

- ◆ 1" Female Connection to Both Dispenser and Underground Piping
- ◆ Multiple Mounting Methods – mounting boss accepts either U-Bolt or Straight-Bolt mounting kits.
- ◆ Duragard® E-Coat Finish – provides superior corrosion resistance.

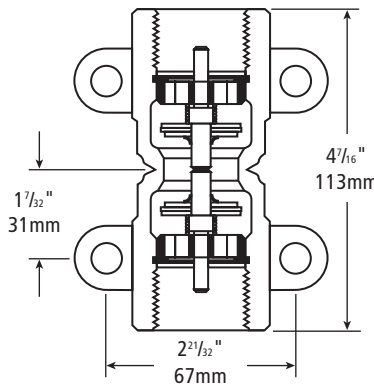

**OPW 60V Series Vapor-Line Shear Valves**

**OPW 60V-1000 Line Saver**

- ◆ Shear section breaks on impact to minimize damage to underground piping.

**OPW 60VP-1001**

**Poppeted Vapor Valve**

- ◆ Double-poppeted design incorporated to help prevent vapor loss in the event dispenser is topped
- ◆ CARB-approved
- ◆ UL-listed 

60V Instruction Sheet  
Order Number: **H12133M**

**Ordering Specifications**

Product #	Connections	Poppeted
60V-1000	1" x 1" (3 x 3 cm) FNPT	
60VP-1001	1" x 1" (3 x 3 cm) FNPT	•
60VK-1002	U-Bolt Mounting Kit Includes: (2) 3/8" (9.5 mm) U-bolts, (4) washers, (4) nuts	
60VK-1003	Straight Bolt Mounting Kit Includes: (4) 3/8" (9.5 mm) 16 bolts, (4) washers, (4) nuts	