

Features

- ◆ **Easy Installation** – a 4" flexible boot on the back panel allows for a quick, simple connection to the remote-fill or vapor lines. Optional reducer inserts are available to accommodate 3" and 2" piping connections
- ◆ **Models to Accommodate Various Fill-Pipe Configurations** – available in 15-, 20- and 30-gallon container capacity. Smaller 15-gallon models are designed for a single-fill or vapor-return connection. Larger 20- and 30-gallon models accept both fill and vapor-return piping in a dual-port configuration. The 30-gallon model will accommodate both fill and vapor-return piping in a single-port configuration and allow the use of 3" Dry Disconnects (OPW 1611AN and 1711D) in a dual-port configuration
- ◆ **Rain-Shedding Cover Design** – hooded cover design helps prevent water or snow entry by extending the lip of the cover over the body of the spill container
- ◆ **12-Gauge Epoxy Powder-Coated Steel or 304 Stainless-Steel Containment Box** – heavy duty materials, compatible with hydrocarbons, for long service life and added security



- ◆ **Welded-Hinge, Lockable Hatch** – cover includes a provision for a padlock and a welded-hinge assembly for added security
- ◆ **Easy Product Drainage** – lockable ball valve drain provides for quick and easy product removal
- ◆ **Height Adjustable** – adjustable legs enable the spill container to be set at a variety of heights, from 16 1/2" to 30". Each leg is independently adjustable to account for uneven ground conditions
- ◆ **Custom Sizes Available Upon Request**



Ordering Chart

6	R -				
211		15	0	B2	L
211SS		20	1	B3	LD
		30	2	B4	N
				N	ND

211 – 12-Gauge Powder-Coated Steel Construction
211SS – Stainless-Steel Construction

15 – 15-Gallon Capacity
20 – 20-Gallon Capacity
30 – 30-Gallon Capacity

0 – No entry holes
1 – 1, 4" Entry hole
2 – 2, 4" Entry holes (20 or 30 Gallon Only)

B – Booted entry fittings in holes
N – No fittings in holes
2 – 2" Fitting
3 – 3" Fitting
4 – 4" Fitting

L – Adjustable legs and No base drain valve
LD – Adjustable legs with base drain valve
N – No legs and No base drain valve
ND – No legs with base drain valve

Note: an item must be selected for each column.

Dimensions

	15 Gallon		20 Gallon		30 Gallon	
	Weight 91 lbs. (41 kg)		Weight 135 lbs. (61 kg)		Weight 175 lbs. (79 kg)	
	in.	cm	in.	cm	in.	cm
A	18 1/4	46	24	61	21	53
B	7 3/8	19	7 1/2	19	10 1/2	27
C	13 5/8	35	16 1/2	42	16 1/2	42
D	16 1/2 to 30	42 to 76	16 1/2 to 30	42 to 76	16 1/2 to 30	42 to 76
E	18 1/4	46	24	61	34	86
F	9 1/8	23	12	30 1/2	9 1/2	24
G	47 to 60 1/2	119 to 154	56 1/2 to 80	144 to 203	56 1/2 to 80	144 to 203

OPW 211-RMOT Remote-Fill Aboveground Storage Tank Spill Containers

OPW Remote-Fill AST Spill Containers are designed to prevent spilled product from entering soil near the remote, horizontal-fill and vapor-return connections on an aboveground storage tank during normal tank-filling operation. The spill containers catch spillage to help prevent soil contamination and groundwater pollution. OPW Remote-Fill AST Spill Containers slip on the remote-fill and vapor-return piping connected to an aboveground tank. Compatible with methanol, ethanol, jet and AV-Gas fuels.

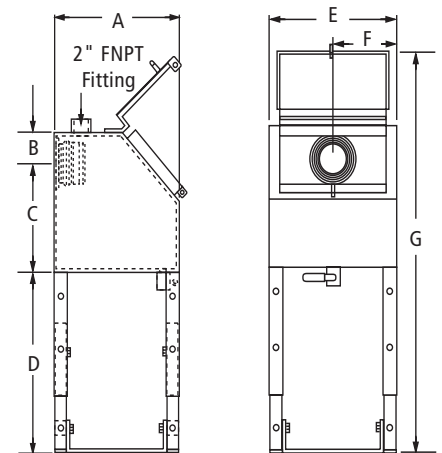

Replacement Parts

Part #	Description
201758	4 x 2 Reducer Insert
201759	4 x 3 Reducer Insert
PBOOT	Nitrile (Fuel-Resistant) Boot
H14228M	Band Clamp for PBOOT
202312	Aluminum Flange
21BV-0075	Fullport 3/4"
6211R-15-LegKit	Leg Kit - 15 Gal.
6211R-20-LegKit	Leg Kit - 20 Gal.
6211R-30-LegKit	Leg Kit - 30 Gal.
PC04427	Brass Drain Valve

211R Instruction Sheet Order Number: **H15857PA**