

PRE-PLUMBED DSE DISPENSER SUMP



Made With

**ADVANCED
COMPOSITE
TECHNOLOGY**

OPW
RETAIL FUELING



**Superior
Components**



**Save Time and
Install Costs**



UL-Listed System

OPW 
RETAIL FUELING
a **DOVER** company

LEARN MORE. VISIT US AT opwglobal.com/opw-retail-fueling/pre-plumed-dse

Factory-Installed and Tested Components

DSE Tops (with Stabilizer Bars)

Compatible with both Wayne Ovation and Gilbarco Encore dispensers, OPW Pre-Plumbed DSE Dispenser Sump tops come pre-installed with stabilizer bars.

10 Plus Emergency Shut-Off Valves

OPW's double-poppet 1.5" emergency shut-off valves come standard in all Pre-Plumbed DSEs. The patented SmartGuard™ design helps contain shear-groove leaks to reduce safety risks. Renewable-fuel / E85 shear valves available.

DSE Dispenser Sump Base

This innovative fiberglass base is made with Advanced Composite Technology, creating consistent, smooth walls (inside and out) to help prevent leaks and other maintenance issues.

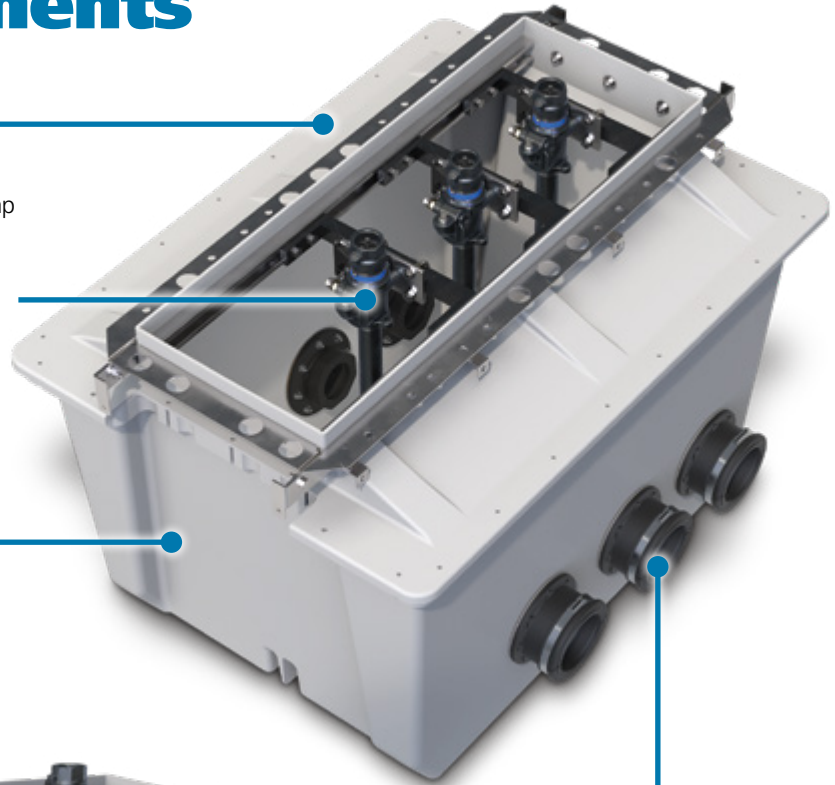

Dual-Sided Pipe Entry Fittings (Rigid or Hybrid)

Rigid (REF) or Hybrid (HEF) Entry Fittings come factory-installed in 1.5" or 2" piping sizes, saving time and resources in the field.

Flex Connectors or NPT Pipe Nipples (Rigid Risers)

Stainless-steel 1.5" x 18" flexible connectors or e-coated NPT pipe nipples (Rigid Risers) are factory-installed and tested.

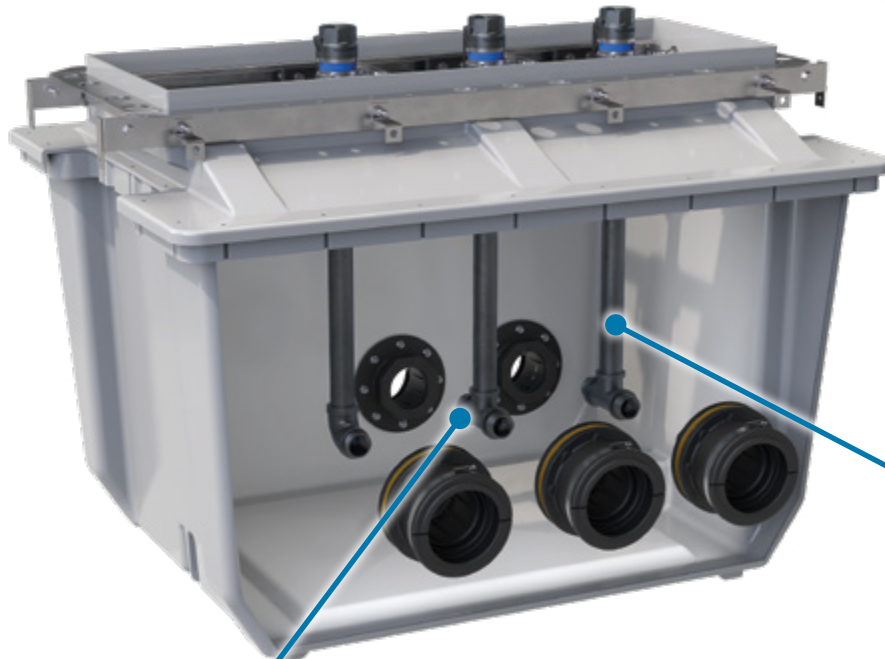

Tees/Elbows

E-coated tees and elbows (1.5" or 2") are pre-installed onto Flex Connectors or Rigid Risers and tested. DPC or SBC compatibility offered.

Pre-Plumbed DSE Dispenser Sump

Utilizing the quality and value of the DSE Dispenser Sump, OPW now offers a Pre-Plumbed DSE model for customers who wish to save time, reduce installation variability and reduce installation costs. Complete with factory-assembled and tested components, the Pre-Plumbed DSE continues the OPW E-Series tradition of superior design, materials and affordability.

Features & Benefits:

Quality Components Factory-Installed – pre-plumbed dispenser sump provides convenience and installation cost/time savings.

Piece-of-Mind Installation – superior components are factory-installed and tested in a controlled environment, helping to eliminate potential costly installation errors in the field.

Advanced Composite Technology – premium fiberglass construction with smooth surfaces on both sides of the sump walls and consistent thickness, blend and shape for strong bonds with entry fittings.

Site Configurable – Built specific to your piping-site layout

Customizable – choose your configuration by dispenser type, entry fittings, traditional or renewable shear valves, flex connector or rigid riser, and pipe-coupling compatibility.

Efficient Manufacturing and Fast Lead Times – provides best-in-class quality and value shipped quickly.

Testable Loop System Advantages – all the features and benefits of the legendary OPW Loop System for use in those jurisdictions that still require piping to slope back to the tank.



Components	Part Configurations			
Base	DSE-BASE			
Tops	DSE-1836	Gilbarco Encore	DSE-1543	Wayne Ovation
Stabilizer Bars	SBK-1800	Gilbarco Encore	SBK-1500	Wayne Ovation
Pipe Entry Fittings	REF-4015	1.5" Rigid Entry Fittings	HEF-4015	1.5" Hybrid Entry Fittings
	REF-4020	2.0" Rigid Entry Fittings	HEF-4020	2.0" Hybrid Entry Fittings
Emergency Shear Valves	10P-0152	10 Plus 1.5" Double Poppet	10P-0152RF*	Renewable Fuel 10 Plus 1.5" Double Poppet
Flex Connectors or Rigid Risers (1.5" x 18")	217817	1.5" NPT Pipe Nipple, 18" length (Rigid Riser)	FC15-SWM18	1.5" Flex Connector Male Swivel x Male, 18" length
Pipe-Coupling Compatibility**	Double Wall Swivel Pipe Couplings (DPC)		Swivel Bolt-On Couplings (SBC)	

*E85/B100 Applications. All shear valves in the Pre-Plumbed DSE will be RF version if selected.

** DPC & SBCs must be purchased separately. The proper e-coated tees & elbows to be pre-installed based on selection.

Pre-Plumbed DSE Dispenser Sump Ordering Guide

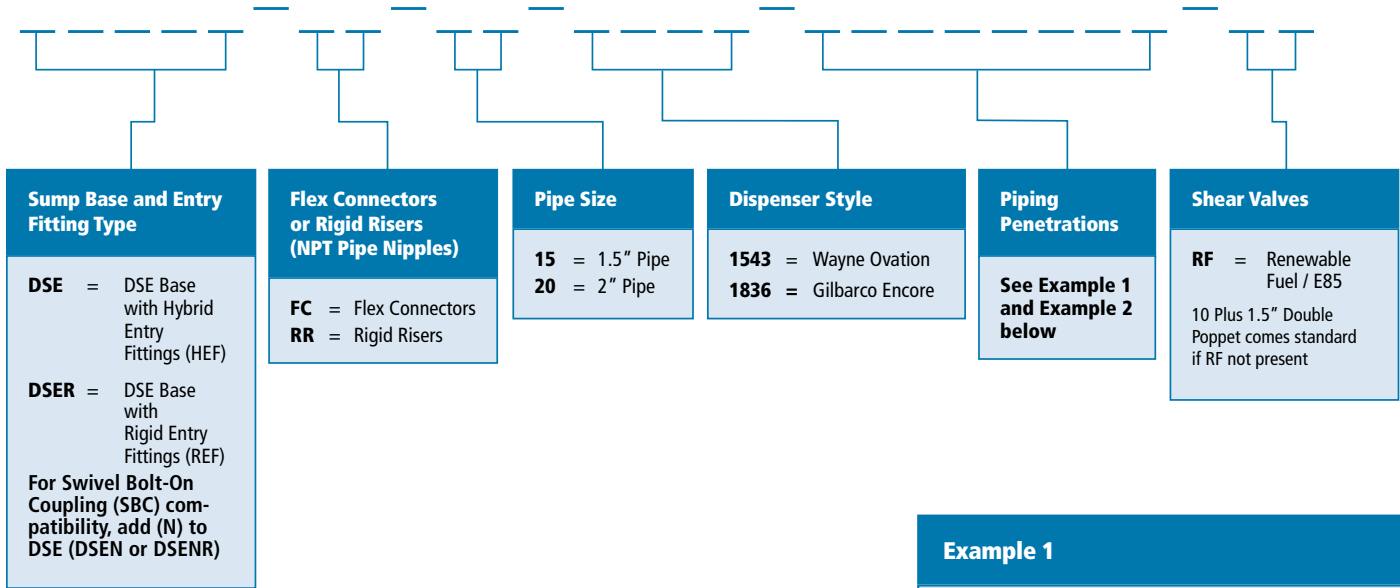

Example 1

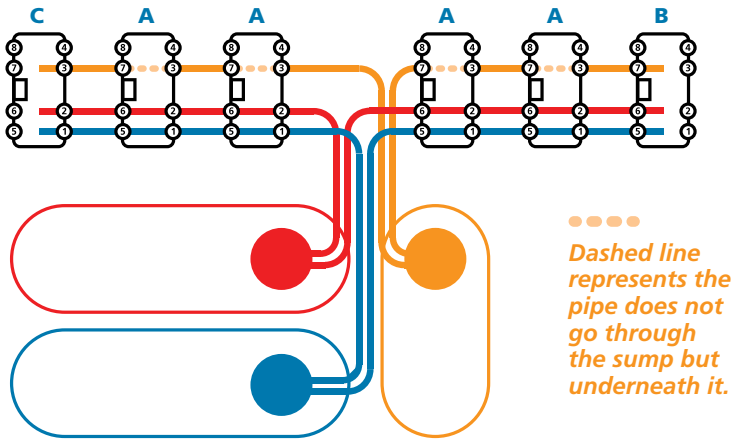

Example 1

- DSE-FC-15-1836-1256
 - DSE-FC-15-1836-567
 - DSE-FC-15-1836-123
- Hybrid Entry Fittings (DSE in part number)
 - DPC compatible (No N present in part number)
 - Flex Connectors (FC in part number)
 - 1.5" pipe (15 in part number)
 - Gilbarco Encore dispensers (1836 in part number)
 - The two 3+1 dispensers have different configurations, B & C

Example 2

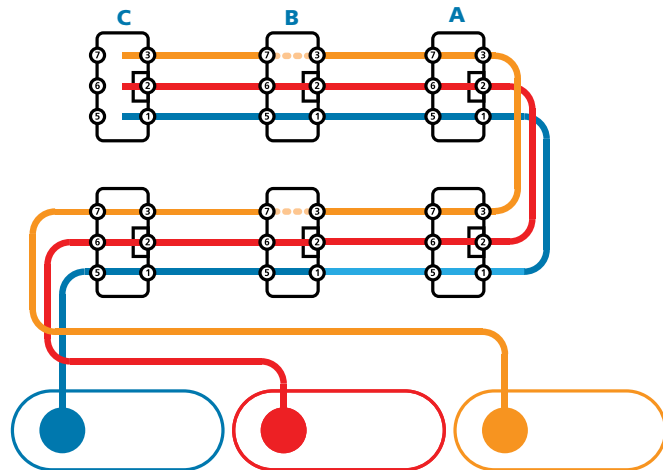

Example 2

- DSENR-RR-15-1543-123567
 - DSENR-RR-15-1543-1256
 - DSENR-RR-15-1543-123
- Rigid Entry Fittings
 - SBC compatible NPT tees/elbows (N present in part number)
 - Rigid Risers (RR in part number)
 - 1.5" pipe (15 in part number)
 - Wayne Ovation dispensers (1543 in part number)
 - The product lines cross in order to keep the dispenser "Side A" consistent