

Petro Vend® 300E (PV300E) Fuel Island Terminal Installation Manual

Part Number: FMM1020

Revision: 3



PV300E Fuel Island Terminal

DFS *Worldwide Brands*



IMPORTANT: Before you use this manual, make sure you have the most recent revision. Look at the revision of this document to make sure it agrees with the most current revision found in the FMS Technical Library. Download the latest revision if necessary.



IMPORTANT: If you have an installation in an area that has possible internet connectivity issues, it is recommended to either print or download these manuals to a mobile device (mobile phone, tablet or iPad) before you go to the installation site.



READ CAREFULLY: OPW Fuel Management Systems and Dover Fueling Solutions cannot be held responsible for installations, configurations or use of its products that does not comply with the most recent documentation available.



NOTE: It will be necessary to have Single Sign-On (SSO) credentials to get access to manuals, instructions, software updates and other important assets. Speak with your FMS sales representative or contact FMS Customer Service at 1-888-679-3835 (1-888-OPW-FUEL) for information. Once you have been approved for SSO credentials go to the [FMS Technical Library](#) to find the most recent revisions of all manuals and instructions.



NOTE: All references to other manuals and instructions in this manual can be found in the FMS Technical Library. Make sure you have the most recent revision.

Related Manuals

Other related manuals necessary to install, configure, maintain or use this product:

[FMM1024-QS PV300E Quick-Start](#)

[FMM1021 PV300E EMV Security Configuration](#)

[FMM1024 PV300E Maintenance Mode](#)



OPW Fuel Management Systems is a part of Dover Fueling Solutions.

Copyright Information

© 2024 Dover Fueling Solutions. All rights reserved. DOVER, the DOVER D Design, DOVER FUELING SOLUTIONS, and other trademarks referenced herein are trademarks of Delaware Capital Formation, Inc./Dover Corporation, Dover Fueling Solutions UK Ltd. and their affiliated entities.

Contact OPW Fuel Management Systems

200A Parker Drive; Suite 400 • Austin, TX 78728

Visit us at <https://www.doverfuelingsolutions.com/>.

Sales Support: (888) 679-3835 (7:30 a.m. to 4:00 p.m., US CST) • Email orders to: FMSorders@doverfs.com • Send billing inquiries to: Dbs_na_ar_inquiries@dovercorp.com

Call 1-877-OPW-TECH (877-679-8324) Monday through Friday, 7 a.m. to 6 p.m., US CST

Table of Contents

Section 1 Class I, Division 2, Group B and Group D Hazardous Area Installations	6
Section 2 PV300E Fuel Control System	7
2.1 Technical Specifications	7
2.2 Important Safety Information	8
2.3 Safety Warnings	9
2.4 Information Panels	9
2.5 Hazardous Areas	11
2.5.1 NFPA/NEC – Class I, Division 1 & Division 2	11
2.5.2 Installation Requirement	12
2.6 Applicable Warnings, Battery Safety	14
2.6.1 Internal Coin Cell Battery Safety	14
2.7 Installer Safety	16
2.8 Electrostatic Sensitive Devices (ESD)	17
2.9 FCC Compliance	18
Section 3 System Conduit & Wiring Requirements	19
3.1 Conduit/Wiring Requirements	19
3.1.1 Aluminum Enclosure Conduit Knockouts	20
3.1.2 Petro-Net Wiring	21
3.2 PV300E Power, Petro-Net and Ethernet	21
3.2.1 Grounding	22
3.2.2 Circuit Breakers	22
Section 4 PV300E Installation	24
4.1 Pedestal Installation	24
4.2 Enclosure Installation on the Pedestal	26
4.3 Enclosure Installation on a Legacy Pedestal	27

Section 5 Receipt Printer Installation	30
5.1 Zebra Printer	31
5.2 Load Receipt Printer Paper	33
5.3 Citizen Printer Installation	36
5.4 Replacement: Old Zebra to New Citizen Printer	38
5.4.1 Install the Citizen Printer	39
5.4.2 Cable Connections	39
5.4.3 Install Paper	41
Section 6 Wiring	42
Section 7 Complete the Installation	44
Section 8 Maintenance	45
Section 9 Optional Wireless Antenna Installation	46
9.1 Terminal Radio Installation	46
9.2 Access Point Installation	51
9.2.1 Window Installation (recommended)	51
9.2.2 Wall Installation	52
9.2.3 Pair the Access Point with the Terminal Radios	52
Appendix A - Component Connections	54
Appendix B - Door Removal and Assembly	57
Appendix C - Service Technician Tools	62

Section 1 Class I, Division 2, Group B and Group D Hazardous Area Installations

For installations inside Class I, Division 2, Group B or Class I, Division 2, Group D hazardous area classifications, refer to the table below for explanations of how wireless and Pump Control Modules (PCM) must be installed to conform to these classifications.

<i>PV300E DIV 2 Installations</i>	
PV300E-Group B: PV300E terminal with T7 but no Avalan or Relay Board options will be suitable for Class I, Division 2, Group B	The PV300E terminal and pedestal can be installed in a classified area but cannot include a terminal wireless option installed in the terminal. No Pump Control Module (PCM) boards are permitted to be installed in the pedestal. A remote PCM enclosure installed in an unclassified location can be used.
PV300E-Group D-in: PV300E terminal with T7 and Avalan's current boards but no Relay Boards will be suitable for Class I, Division 2, Group D	The PV300E terminal and pedestal can be installed in a classified area. For Group D, installation can include a terminal wireless option installed in the terminal. No Pump Control Module (PCM) boards are permitted to be installed in the pedestal. A remote PCM enclosure installed in an unclassified location can be used.
PV300E-Group D-over: PV300E terminal with T7, Avalan, and Relay Boards for installation in an unclassified area.	A PV300E terminal and pedestal can be installed in an <i>unclassified area</i> . Installation can include a terminal wireless option installed in the terminal. Pump Control Module (PCM) boards installed in the pedestal are permitted only if the installation is in an unclassified area.

For information about PCM remote installations, refer to [FMM00-20-0340 PCM Installation Operation and Maintenance Manual](#), Remote PCM Installation.

Section 2 PV300E Fuel Control System



This manual includes specified information about the PV300E. Information related to the FSC3000 Fuel Site Controller can be found in the [M1700 FSC3000 Installation, Operation and Maintenance Manual](#).

2.1 Technical Specifications

<i>Specification Table</i>	
Cabinet Dimensions:	W - 17.51 in (44.48 cm) H - 12.28 in (31.19 cm) D - 10.55 in. (26.80 cm)
Pedestal Dimensions:	40 inch H x 14 inch W x 9 inch D (122 cm x 36 cm x 23 cm) is standard; 32-inch and 48-inch heights are optional
Power Requirements:	120 VAC, 50/60 Hz, 450 Watts Maximum
Operating Temperature Range:	-40°F to 122°F (-40°C to 50°C)
Range of Environmental Conditions:	Outdoor use, Altitude less than 5000 m, temperature range, relative humidity (80 % for temperatures up to 31 °C decreasing linearly to 50 % relative humidity at 40 °C), Wet location, Pollution degree 2
Graphics display:	7 inch (18 cm) color display
Pedestal and Cabinet:	Powder-coated aluminum
Reader Options:	Standard: Combination EMV contact / magnetic stripe Optional: NFC (Contactless EMV)
Pedestal Options:	48 inch (Standard) 40 inch: 40 inch ADA (Americans with Disabilities Act) compliant for off island installations 32 inch: 32 inch ADA compliant for on island installations

2.2 Important Safety Information

You must read and understand all safety information in this manual.



IMPORTANT: ONLY APPROVED, TRAINED TECHNICIANS ARE PERMITTED TO INSTALL OR DO SERVICING ON THE EQUIPMENT AND COMPONENTS SHOWN IN THE PROCEDURES IN THIS MANUAL.

For your protection, obey all safety panels, warnings and instructions where they occur.

Read the safety and compliance information completely in the sections that follow before you begin installation.



DANGER: To prevent the possibility of explosion or fire, do not use electrical or battery operated power tools in or near the Hazardous Area! Only use pneumatic or hand tools.



2.3 Safety Warnings

This manual contains many important Safety Alerts. There can be a risk of injury or damage to property if you do not obey these alerts. The panels below show the types of safety warnings that can be seen and how each is specified.



DANGER: Indicates an immediately hazardous condition that, if not prevented, will result in death or serious injury.



WARNING: Indicates a possibly hazardous condition that, if not prevented, could result in death or serious injury.



CAUTION: Indicates a possibly hazardous situation that, if not prevented, could result in minor or moderate injury.



NOTICE: Indicates important information not related to hazards. A condition that, if not prevented, can result in property damage.



SAFETY INSTRUCTIONS: Indicates instructions and procedures related to safety or gives the location of safety equipment

2.4 Information Panels



NOTE: This panel gives more information about an instruction or procedure.



IMPORTANT: This panel contains special information that is important and must be read and obeyed.



REMINDER: This panel shows information that has been given before in the manual that is important to show again.



TIP: A step or procedure that is recommended to make another step or procedure easier.



INFORMATION: This panel shows references to more information in other sources.



READ CAREFULLY: This panel points to information that must be fully read and understood before doing the procedure(s) that comes after.

2.5 Hazardous Areas

Any fuel dispenser is a hazardous area as defined in the National Electrical Code. Installation must be in accordance with the following:

- National Electrical Code (NFPA No. 70)
- Motor Fuel Dispensing Facilities and Repair Garages Code (NFPA No. 30A)

2.5.1 NFPA/NEC – Class I, Division 1 & Division 2

The Class I, Division 1 and Class I, Division 2 hazardous areas are specified below:

Class I locations. Class I locations: Where flammable gases or vapors are or can be in the air in quantities sufficient to cause explosive or ignitable mixtures. Class I locations include:

- **Class I, Division 1.** A Class I, Division 1 location is a location where:
 - There can be concentrations of flammable vapors during normal operation.
 - There can be concentrations of flammable vapors during repair or maintenance operations or when the leakage of liquid fuel can occur.
 - A release of concentrations of flammable vapors can occur as a result of equipment failure, incorrect operation or unsatisfactory procedures that could also cause a failure of electrical equipment.
- **Class I, Division 2.** A Class I, Division 2 location is a location where:
 - An accidental failure or incorrect operation of vapor containment system equipment or containers that can release hazardous vapors from flammable liquids or gases.
 - A failure or incorrect operation of positive mechanical ventilation precautions result in the release of hazardous concentrations of flammable gases or vapors.
 - Concentrations of flammable gases or vapors can occasionally flow from a containment or ventilation system to an adjacent Class I, Division 1 location. This flow of gases or vapors must be prevented by sufficient positive-pressure ventilation from a source of clean air. Sufficient precautions to prevent ventilation failure must be installed.



WARNING: To prevent possible fire or explosion, do not mount your system site controller or any other electrical part of the system, including printers and modems, within or above the defined "hazardous" areas.



IMPORTANT: It is the installer's responsibility to know and obey all local codes.



NOTE: Local codes can dictate specific installation requirements. Installation is subject to approval by the local authority that has jurisdiction at the site.

2.5.2 Installation Requirement

OPW-FMS terminals are designed to be installed above the hazardous area when using the terminal's associated pedestal.

The pedestal can be mounted in the hazardous area but a seal-off must be the first fitting for all conduits that go into the area.



IMPORTANT: All unused knockout holes that have been removed must be sealed.

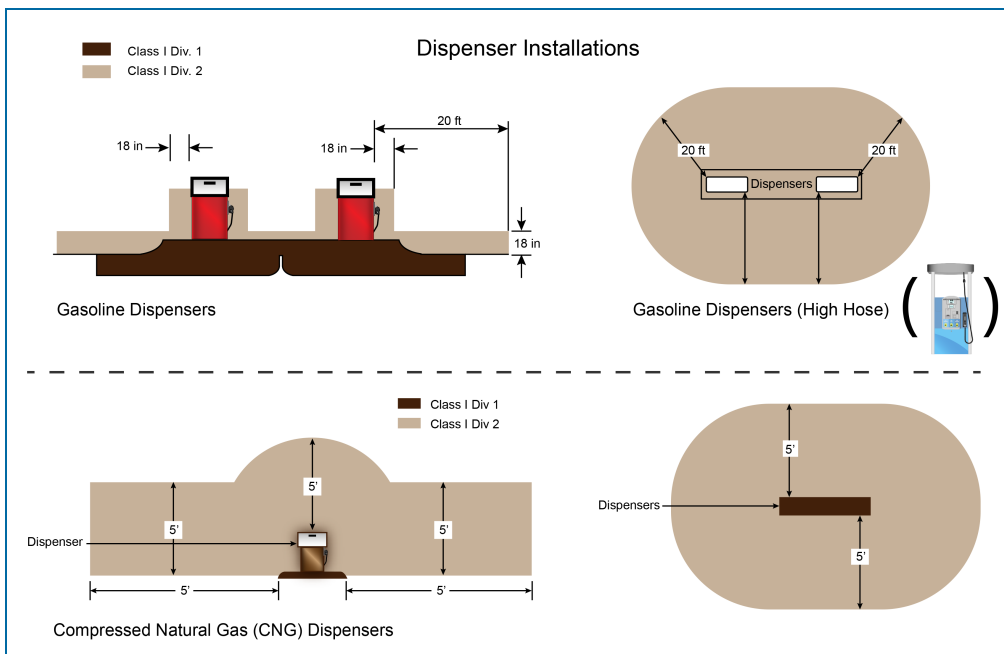

Figure 2-1 Dispenser Installations



WARNING: Knockouts and installation hardware are provided for all cabinetry. Do **NOT** drill holes in the enclosures. This would violate the safety listing of the system.





CAUTION: Be sure to wear all required personal protective equipment (PPE). This includes safety glasses, hardhat, safety shoes and reflective vest.

Barricade the work area before installation.

Be sure to obey all applicable Lockout/Tagout (LOTO) procedures before installation.



WARNING: EXPLOSION HAZARD! DO NOT RESET THE CIRCUIT BREAKER UNLESS POWER HAS BEEN REMOVED FROM THE EQUIPMENT OR THE AREA IS FREE OF IGNITIBLE CONCENTRATIONS.

EXPLOSION HAZARD! DO NOT REMOVE OR REPLACE FUSES WHEN THE TERMINAL IS ENERGIZED.

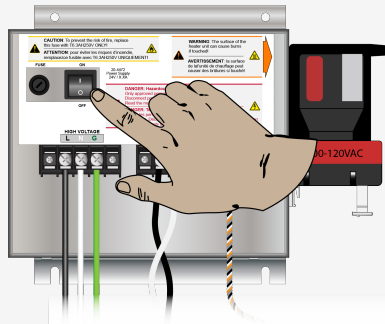

IMPORTANT: It is recommended to do a check of the electrical system with a multimeter to make sure all connections are de-energized before you proceed with the installation.

2.6 Applicable Warnings, Battery Safety

The inside of OPW-FMS system terminals contain high-voltage circuitry. ONLY certified technicians should gain access to the console.



NOTE: Only certified OPW-FMS technicians are authorized to install and program this system. This is necessary for warranty registration.

2.6.1 Internal Coin Cell Battery Safety



DANGER: The coin cell battery can explode if it is used incorrectly. Do not recharge, disassemble or discard this battery in fire. Replace the coin cell battery with Panasonic or Matsushita Electric Part Number CR-2450 Renata 2450N or equivalent ONLY. There can be a risk of fire or explosion if an incorrect battery is used.



To avoid possible explosion or fire, do not replace the lithium battery with a type that is not compatible.

The battery used in this device can present a risk of fire or chemical burn if used incorrectly. Do not disassemble, heat above 100°C or incinerate.

Discard a used, replaced battery immediately. Keep away from children. Do not disassemble and do not discard in fire.

The inside of the console contains high-voltage circuitry; ONLY certified technicians should be permitted access to the console.





INFORMATION: For more safety information on the CR2450 Renata 2450N coin cell Lithium battery used in this device, refer to the [Renata Product Safety Data Sheet](#).

2.7 Installer Safety



CAUTION: Incorrect installation can cause a risk of injury to installers and users of this equipment. Incorrect installation can result in environmental contamination or equipment damage. Read these instructions carefully!



Refer to the National Electrical Code (NFPA No. 70) and the Motor Fuel Dispensing Facilities and Repair Garages Code (NFPA No. 30A) to make sure your installation is correct.

Installers must obey the instructions in this document to complete a safe installation.

For installations outside the United States, make sure that the installation obeys all applicable local codes.

The installer must know and obey all applicable local codes in the country or county where this unit is installed.



NOTE: Local codes can specify special installation requirements. Installation is subject to approval by the local authority with jurisdiction at the site.

2.8 Electrostatic Sensitive Devices (ESD)

This product contains components that can be damaged by Electrostatic Discharge. See the instructions below to work safely with these components.



ATTENTION: Electrostatic Sensitive Device - To prevent damage from electrostatic discharge, obey the precautions below when it is necessary to move or touch electrostatic sensitive devices.

- Use correct grounding methods.
- Use an ESD Field Service Kit with wrist strap, dissipative mat and grounding cord when possible.
- When possible, do not stand on carpeted surfaces while you do work with Electrostatic Discharge Sensitive (ESDS) devices.
- Do not keep ESDS components/assemblies where there is a risk of damage.
- A new component should be kept in its anti-static package as long as possible before installation.
- Only touch ESDS components by the edges. Do not touch any of the circuitry.

2.9 FCC Compliance

This system complies with Part 15 of the Federal Communications Commission (FCC) Rules & Regulations. Operation is applicable to these conditions:

- This device must not cause harmful interference.
- This device must accept interference received. This includes interference that can cause undesired operation.

Section 3 System Conduit & Wiring Requirements

These installation instructions are for a typical installation. Not all possible scenarios can be shown because of the many possible configurations of the system and because every site is different.

Local codes can have specific installation requirements. Installation is subject to approval by jurisdictional authorities at the site of installation. **See the safety information and precautions at the beginning of this manual.**

3.1 Conduit/Wiring Requirements



IMPORTANT: All wiring and conduit runs must conform to the National Electric Code (NFPA No. 70), Motor Fuel Dispensing Facilities and Repair Garages Code (NFPA No. 30A) and all national, state and local codes.

All wiring running to the system must be installed in threaded, rigid metal conduit and have the required seal-offs. AC and DC power wires can share conduit, provided they meet the Petro-Net™ wiring specified; otherwise AC and DC power wires must be installed in separate conduits.



WARNING: The PV300E system must be installed outside of the hazardous area. When the pedestal is equipped with a knockout plate, the plate must be a minimum of 18 inches above the base. All pedestal conduit seal-offs must be above the hazardous area. Any unused knockout holes that have been removed must be sealed.

Install your PV300E a minimum of 18" (45.7 cm) from the nearest conventional pump or dispenser or a minimum of 18" (45.7 cm) from the nearest overhead pump or dispenser.



3.1.1 Aluminum Enclosure Conduit Knockouts

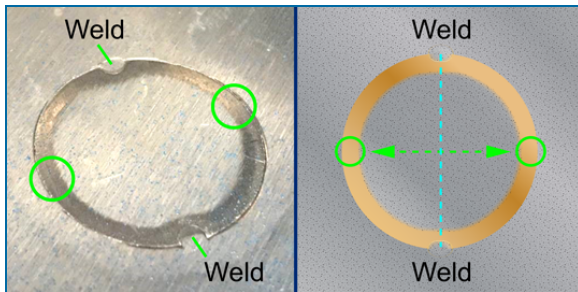

To remove the Knockout plugs in the bottom of the enclosure, hold a center-punch in the **green** circled areas shown in the illustrations above, and hit the punch with a hammer. The areas to hit are perpendicular to the welds that hold the knockouts. Deburr the hole with a file and make sure there are no shavings inside the enclosure.



IMPORTANT: All unused, open knockouts **MUST** be sealed to meet NEC compliance codes!

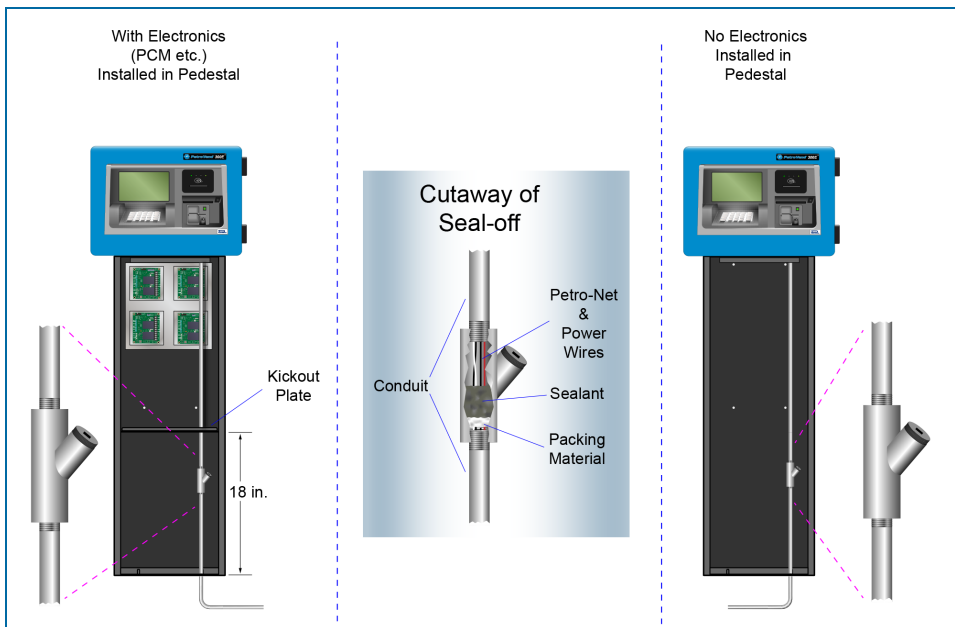

All conduits in the pedestal should terminate into a seal-off. The seal must be the first fitting where the conduit emerges from grade. Install 1/2" (1.3 cm) or 3/4" (1.9) rigid steel conduits, as applicable, to the area where the pedestal is to be located:

- To the PV300E power source.
- To other PV300E terminals or external Fuel Site Controller (FSC) junction box for Petro-Net communications.
- Ethernet (required) to the indoor FSC / EDGE location.

- To each mechanical pump or dispenser for control and pulser wires (for pedestal mounted PCMs only).

3.1.2 Petro-Net Wiring

The PV300E, PCMs, FSC and other devices communicate through an RS-485 protocol called Petro-Net™. **Petro-Net wiring is only necessary when there are PCMs installed in the pedestal.** Petro-Net wiring is a twisted-pair of 18 AWG wires that must be twisted together to provide immunity to electrical noise. You can order Petro-Net from OPW-FMS as Part #: 12-1029.

Petro-Net wiring can run a maximum of 5,000' (1,524 m).

3.2 PV300E Power, Petro-Net and Ethernet

Conduit Requirements

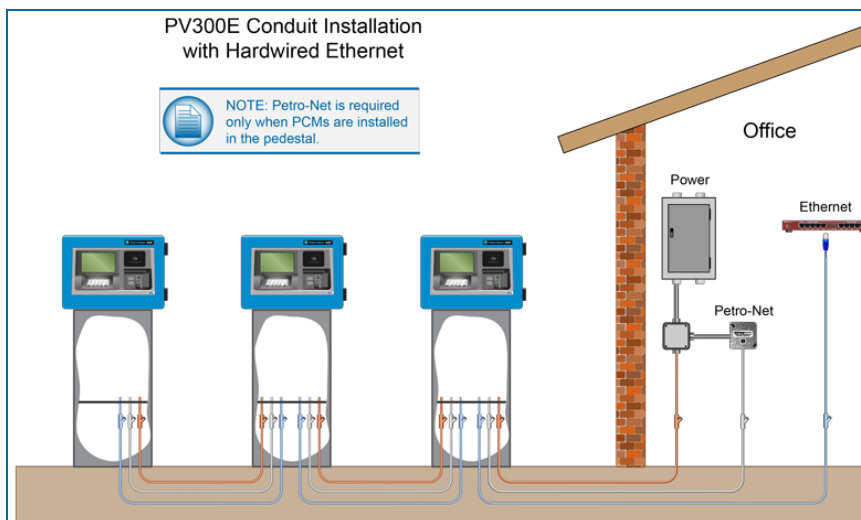
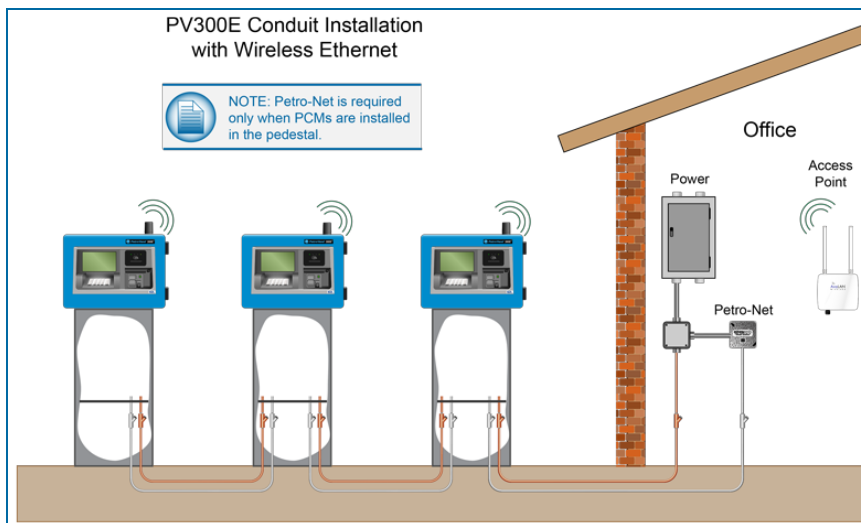

Terminal Power, Petro-Net and Ethernet Conduit

The Power conduit should run from the main circuit panel to each Terminal and can be looped from terminal to terminal. This conduit should only contain the Terminal Feed, Terminal Neutral and Ground wires.

The Petro-Net conduit should run from the Petro-Net Junction Box to each Terminal and can be looped from terminal to terminal. This conduit should only contain the Petro-Net (RS-485) twisted pair wiring.



NOTE: Petro-Net wiring is only necessary when there are PCMs installed in the pedestal.

For installations that use hardwired Ethernet communication, install a conduit from the Ethernet source to each terminal and can be looped from terminal to terminal.

Petro-Net wiring can share terminal power conduit when the Petro-Net cable voltage insulation rating is 600V.

<i>Terminal Power, Petro-Net and Ethernet Wiring Requirements</i>	
Terminal Feed	Minimum #14 AWG Stranded (Black) - Oil/Gas resistant, Wet Locations
Terminal Neutral	Minimum #14 AWG Stranded (White) - Oil/Gas resistant, Wet Locations
Terminal Ground	Minimum #14 AWG Stranded (Green) - Oil/Gas resistant, Wet Locations
Petro-Net (RS485)*	Two (2) #18 AWG twisted (10 per ft) pair - 600V-rated - Oil/Gas resistant, Wet Locations
Ethernet	Standard Cat5, Cat5e, Cat6 Ethernet cable (max. 328 ft. [100 m])



IMPORTANT: *Petro-Net wiring can share terminal power conduit **ONLY** when the Petro-Net cable voltage insulation rating is 600V.

3.2.1 Grounding

The PV300E incorporates internal noise suppression circuitry. For safe and proper operation of this equipment, all devices in the system must be grounded.

A ground wire (Green recommended) must be connected between the device's ground terminal and the main electrical service panel. One earth ground connection is required for each OPW-FMS device.



WARNING: Do not rely on the conduit to provide ground connections.



3.2.2 Circuit Breakers

Power to the PV300E must be supplied from dedicated circuit breakers. No other equipment should be powered from these breakers. This includes the pumps to be controlled.

The AC power for the PV300E can be grouped together for multiple units. It is recommended that no more than eight (8) PV300E terminals be supplied from one breaker.

Section 4 PV300E Installation

The pedestal is available in 3 heights:

- 48 inch
- 40 inch (Standard) ADA (Americans with Disabilities Act) compliant for off island installations
- 32 inch ADA compliant for on island installations

4.1 Pedestal Installation



INFORMATION: For your reference, the illustration below shows the dimensions and hole placement of the pedestal's base plate, top plate, conduit knockout plate and the outer dimensions of the pedestal.

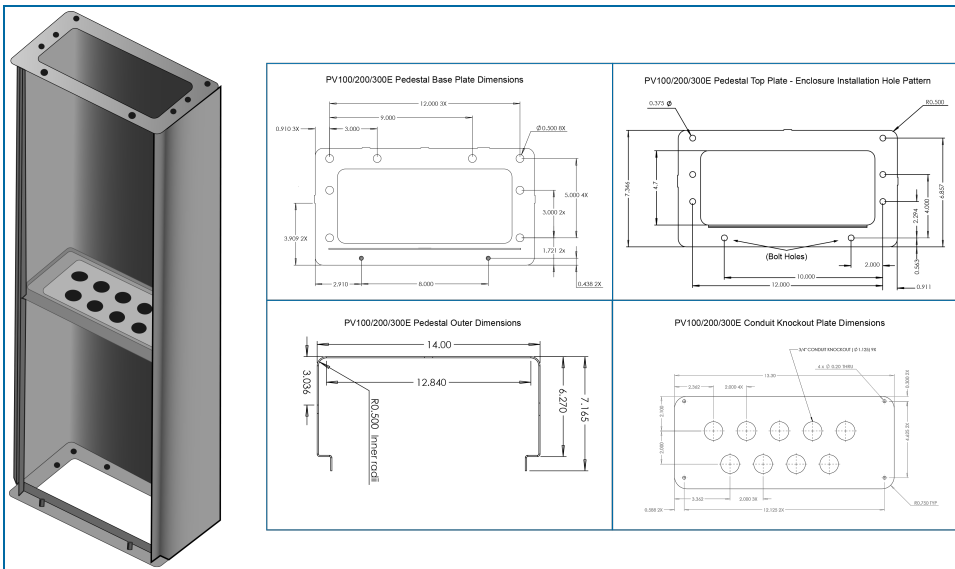

1. Square the base-plate where it is to be installed.

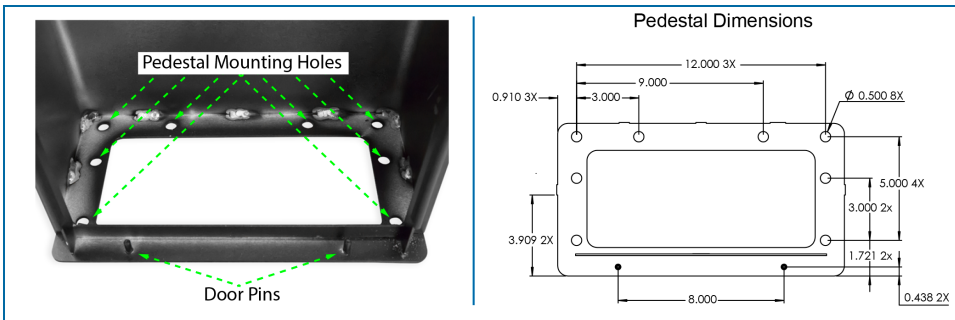

2. Mark the four (4) most applicable locations for the anchor bolts. There are eight (8) bolt holes (see the illustrations below).
3. Drill the holes.
4. Anchor the pedestal with 3/8" anchor bolts.



IMPORTANT: Use a type of anchor bolt that is appropriate for the material in which you will anchor the pedestal (e.g. concrete).



INFORMATION: The illustration below shows the height dimensions of the three available pedestal heights.

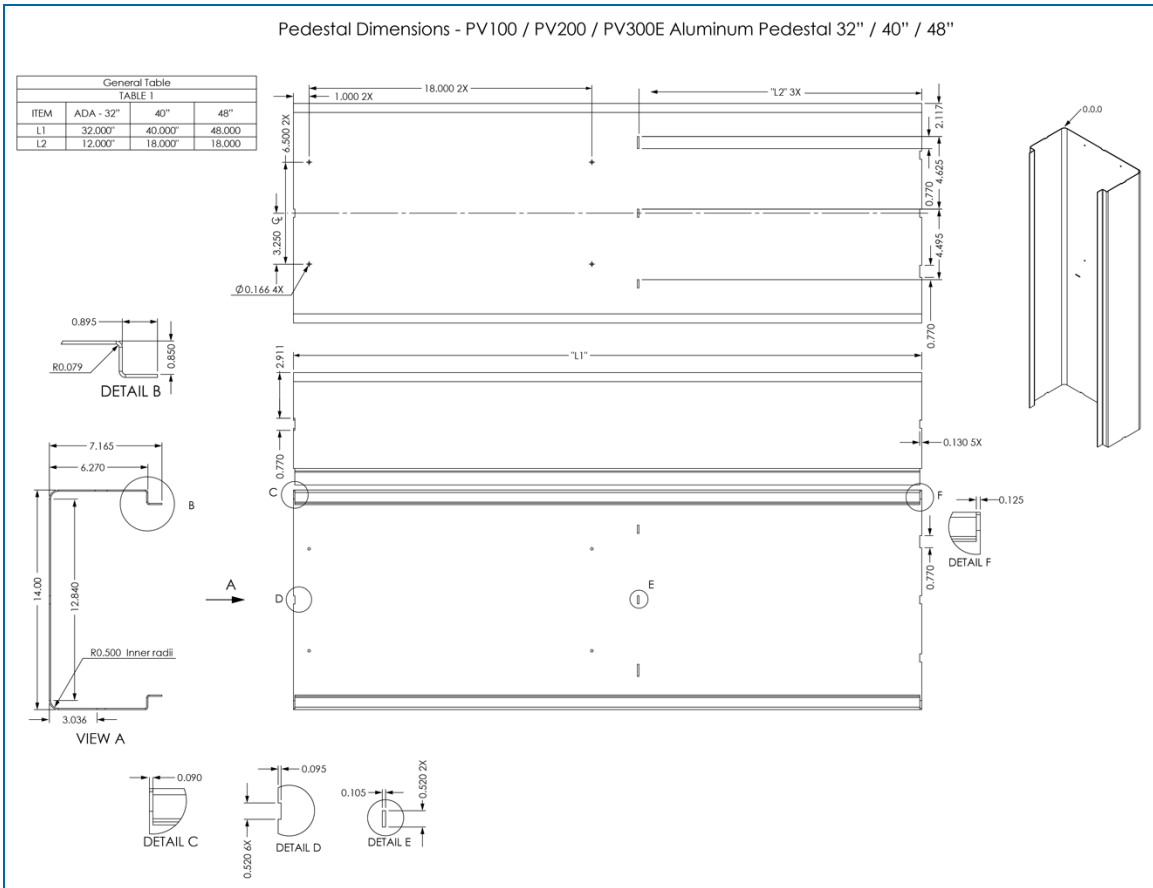

4.2 Enclosure Installation on the Pedestal

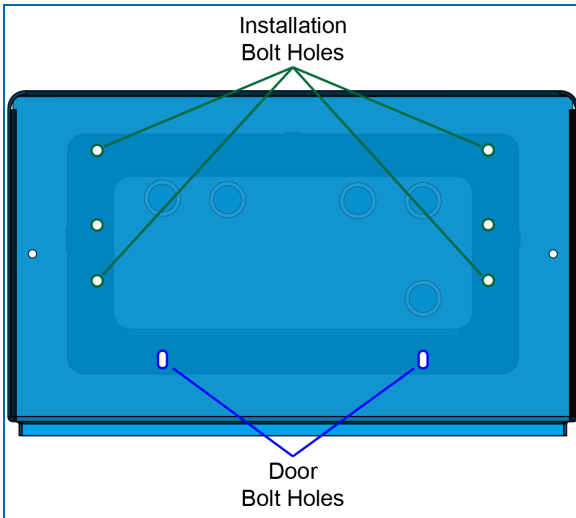

The enclosure has six (6) pre-drilled holes, four (4) that will be used to install the enclosure on the top of the pedestal (see the illustration above). There are two (2) slotted holes to hold the door assembly.

To install the enclosure on the pedestal:

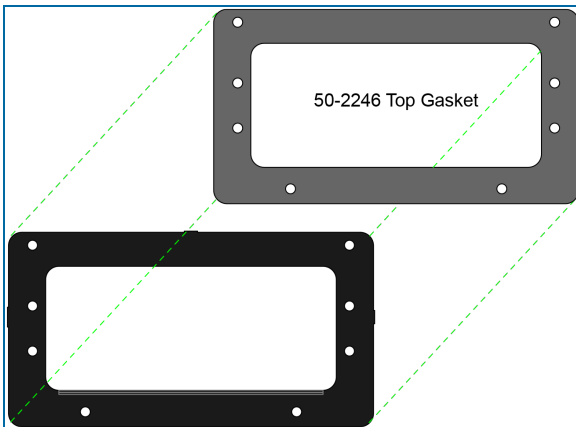

Put the gasket (part number FM50-2246, supplied with the pedestal) on the top plate of the pedestal so that the bolt holes of the gasket align with the holes in the pedestal top plate.

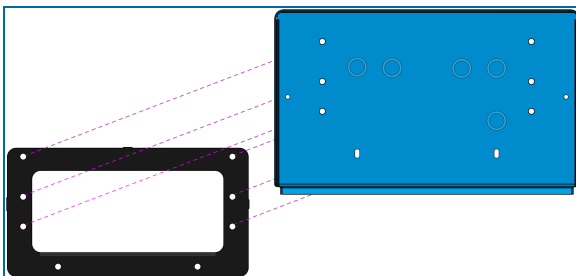

Put the enclosure on the top plate/ and gasket of the pedestal so that the bolt holes of the enclosure align with the holes in the pedestal top plate and gasket.

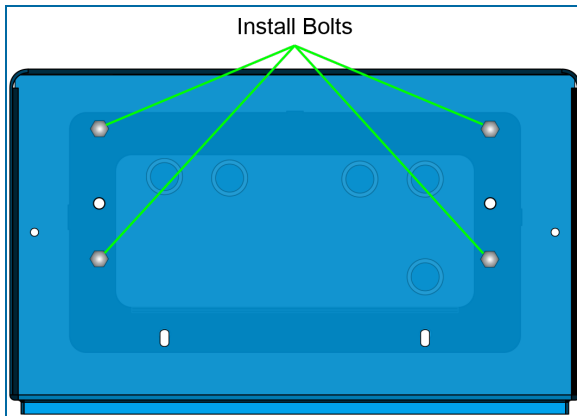

Put the four (4) bolts through the holes and tighten them. Use the provided washers and nuts.



NOTE: The bolts can be put through the holes from the top, inside the enclosure with the washers and nuts on the bottom in the pedestal or from the opposite side (the bolts put through from the bottom, inside the pedestal and the washers and nuts on the top in the enclosure).

4.3 Enclosure Installation on a Legacy Pedestal

(P/N 20-4137)

A PV300E terminal can be installed on an OPW-FMS legacy pedestal (P/N 20-4137) where it will replace a different terminal.

Disconnect all wiring to the terminal to be replaced.

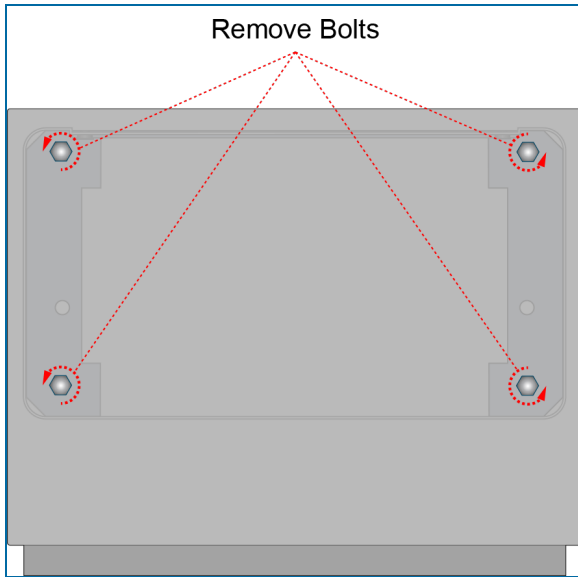

Remove the bolts that hold the terminal to be replaced. Remove the terminal head. Inspect the gasket. Replace it if it is worn.

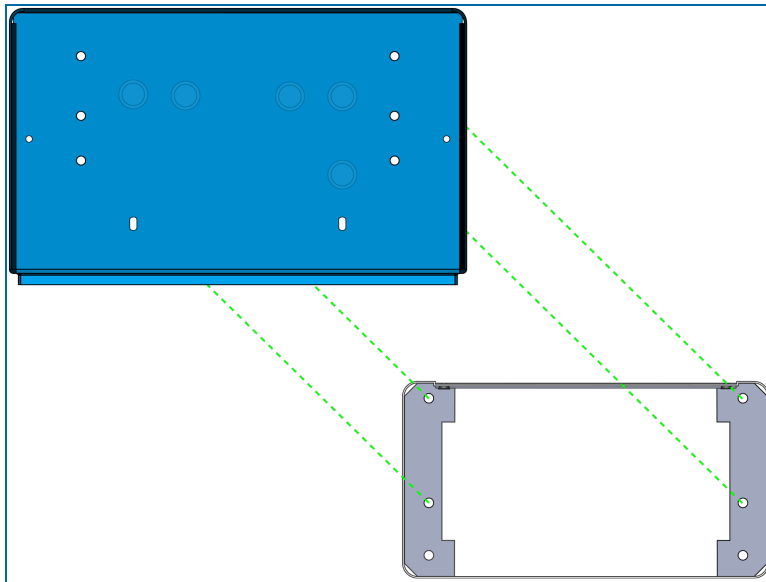

Put the PV300E enclosure on the top plate/ and gasket of the pedestal so that the bolt holes of the enclosure align with the holes in the pedestal top plate and gasket.

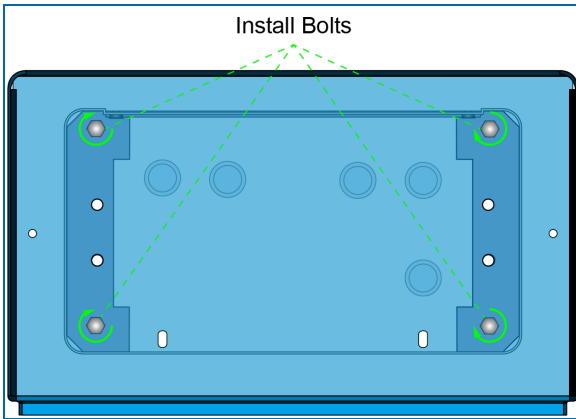

Put the four (4) bolts through the holes and tighten them. Use the provided washers and nuts.



NOTE: The bolts can be put through the holes from the top, inside the enclosure with the washers and nuts on the bottom in the pedestal or from the opposite side (the bolts put through from the bottom, inside the pedestal and the washers and nuts on the top in the enclosure).

Section 5 Receipt Printer Installation



WARNING: To prevent dangerous conditions, make sure all power to the terminal is disconnected when you do the procedures that follow.



The Receipt Printer is not factory installed. To prevent damage during shipping, the printer comes in a box inside the carton with the enclosure assembly.

The printer must be installed after the physical pedestal and enclosure installation is complete and before the terminal configuration.



Carefully remove the **Receipt Printer** from the box.

5.1 Zebra Printer

The instructions that follow show how to field install a Zebra receipt printer.

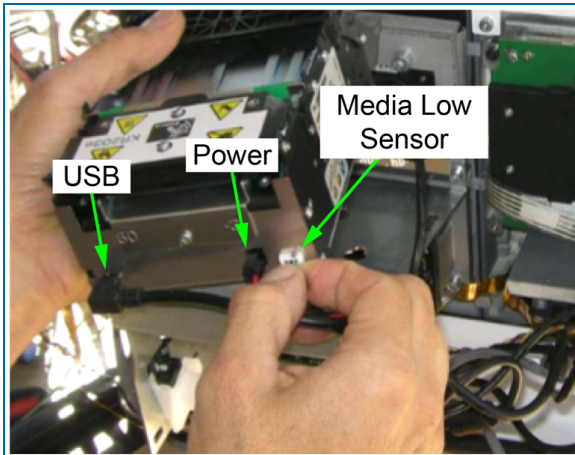

Connect the three (3) printer cables as shown in the photo. The USB and power cables are pre-connected to their sources under the cover to the right of the printer bracket. The cover does not need to be removed. The Media Low sensor cable is pre-connected to its socket in the paper spool assembly.

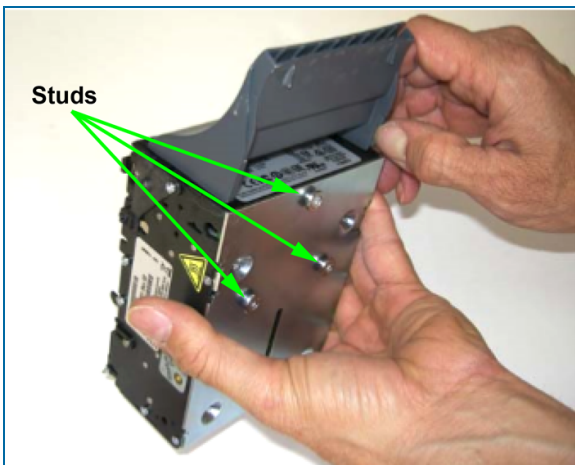

On the bottom of the printer you will see three (3) studs.

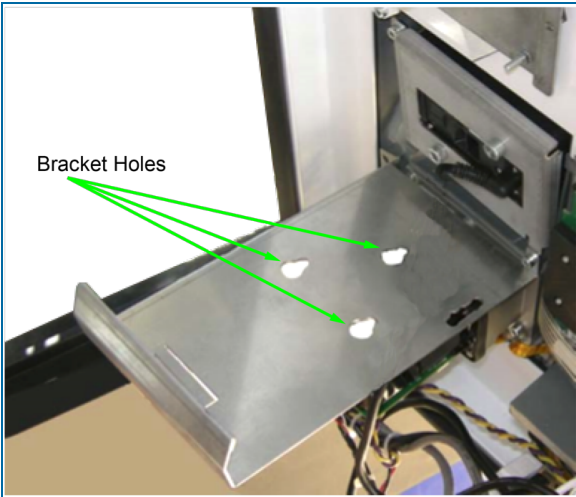

The studs will go into the three (3) holes in the bracket.

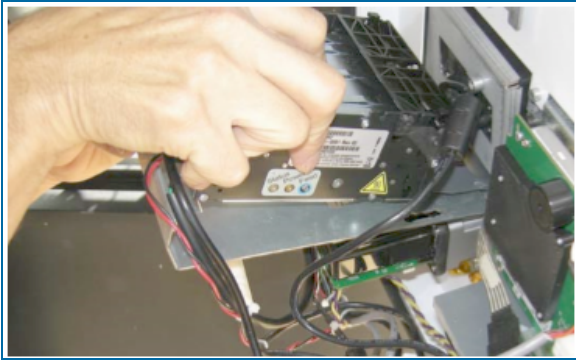

Put the printer on the bracket so that the studs align with the holes. Push the printer forward until it stops.

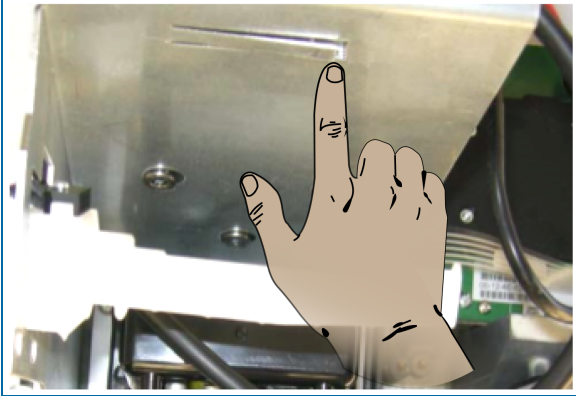

There is a latch on the bottom of the bracket. Push this latch up to lock the printer in position.

5.2 Load Receipt Printer Paper



IMPORTANT: When the printer is out of paper during normal operation, the terminal must be set in Maintenance Mode before you unlock and open the terminal. If you do not obey this instruction the terminal can be put into a BREACHED condition. Refer to M1024-MM Maintenance Mode Reference Guide for instructions to set the terminal in Maintenance Mode.

Set the Terminal in Maintenance Mode

Unlock and open the terminal door to get access to the printer.

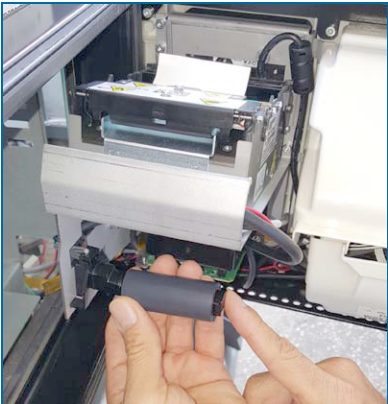

Remove the old paper core.

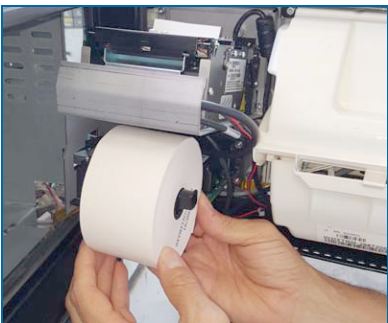

Put the new paper roll on the spindle.

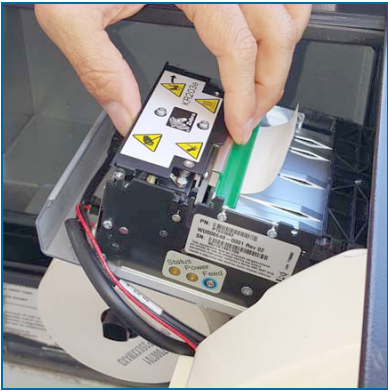

Push the green lever in.

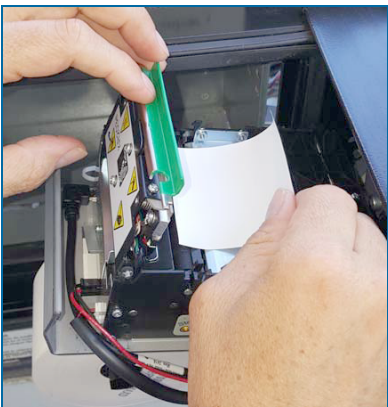

Lift the print head to release the old paper and pull it out.



Put the new paper into the slot in the printer.



The printer will automatically advance and cut the paper.

Close and lock the terminal door.

Set the terminal back in Operational Mode (refer to M1024-MM Maintenance Mode Reference Guide)

5.3 Citizen Printer Installation

The instructions that follow show how to field-install a Citizen receipt printer.

The data and power cables are pre-connected to their sources under the cover to the right of the printer bracket. The cover does not need to be removed.

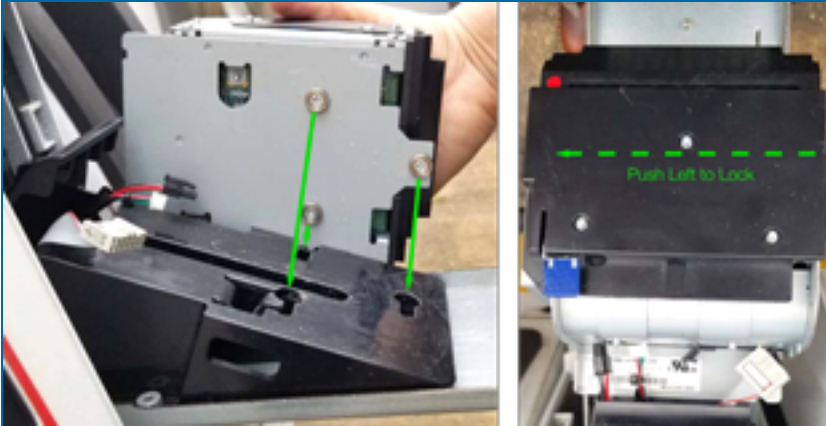

Align the screws in the bottom of the printer unit with the holes of the factory installed bracket. Make sure that no cables get caught under the unit. When the screws are in the bracket holes, push the unit to the left until it clicks.

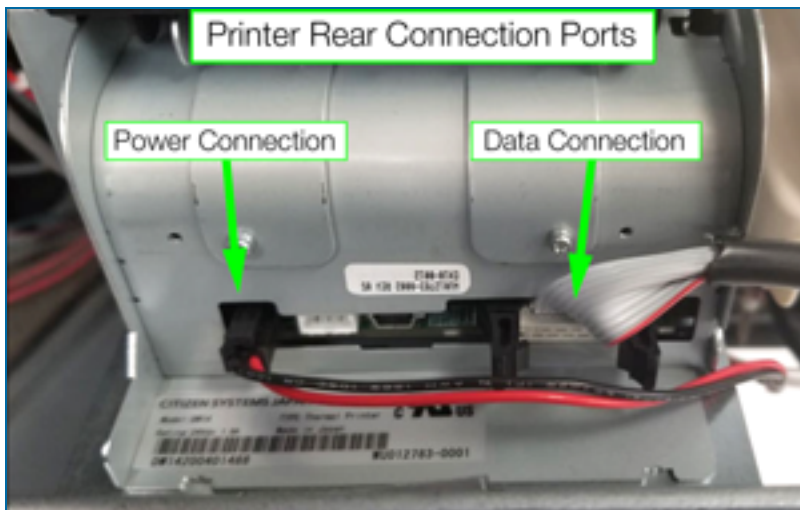

Find the Data Cable end with the mark, P50. Connect it to the snap-in connector on the right rear of the printer as shown above.

Connect the printer's Power Cable to the power connector on the left rear of the printer.

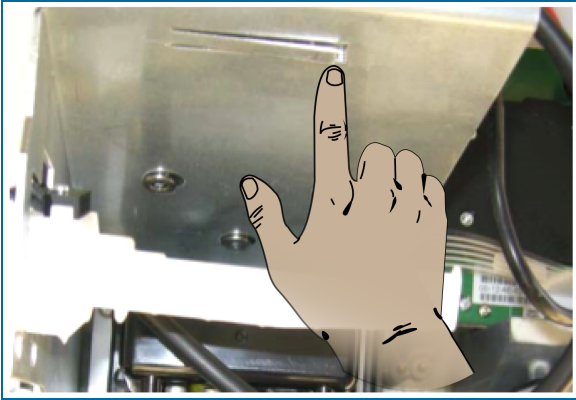

There is a latch on the bottom of the bracket. Push this latch up to lock the printer in position.

5.4 Replacement: Old Zebra to New Citizen Printer

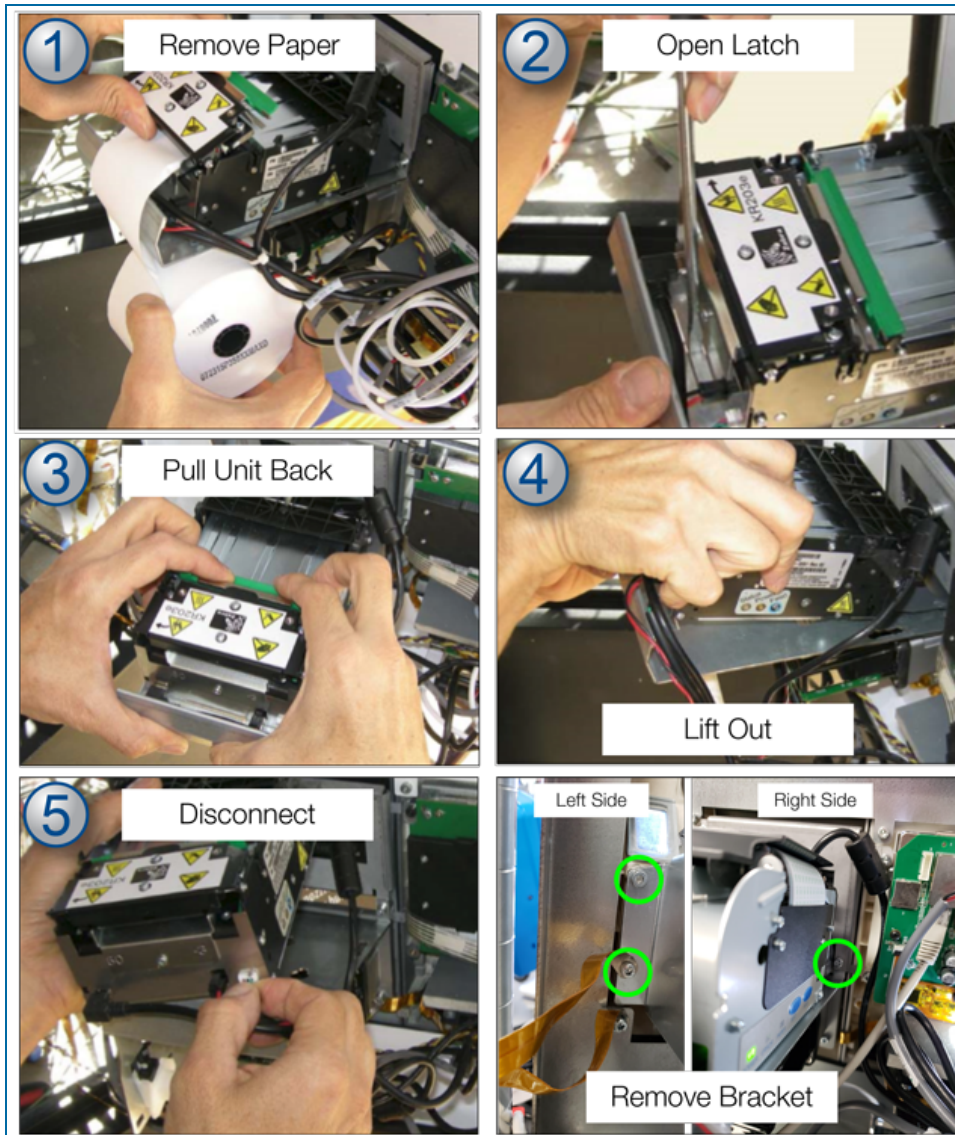

1. Remove the receipt paper from the printhead and remove the paper spool.
2. Push down on the metal latch with a screwdriver until it bends below the bottom of the bracket.
3. Pull the unit back to disengage it.
4. Lift the printer out.
5. Disconnect the Power, USB and Media Sensor cables from the back of the unit.
6. Remove the three (3) screws that hold the printer bracket to remove the bracket. Do not remove the ground strap from the ground screw below the bracket.

5.4.1 Install the Citizen Printer

- Unpack the Citizen replacement printer.
- Install the bracket for the Citizen printer with the same screws that were removed above. Be sure to connect the ground strap to the left bottom screw.
- Refer to the installation instructions in the previous section above.

5.4.2 Cable Connections



NOTE: The USB cable that was used on the Zebra printer is not used for the Citizen printer.



The Citizen printer Data Cable has the ends marked P7 and P50.



To connect the P7 end of the Data cable it is necessary to remove the SPM (Secure Payment Module) cover. Push the latch tab of the SVM (Secure Video Module) cover up to release. Pull the SPM cover out.

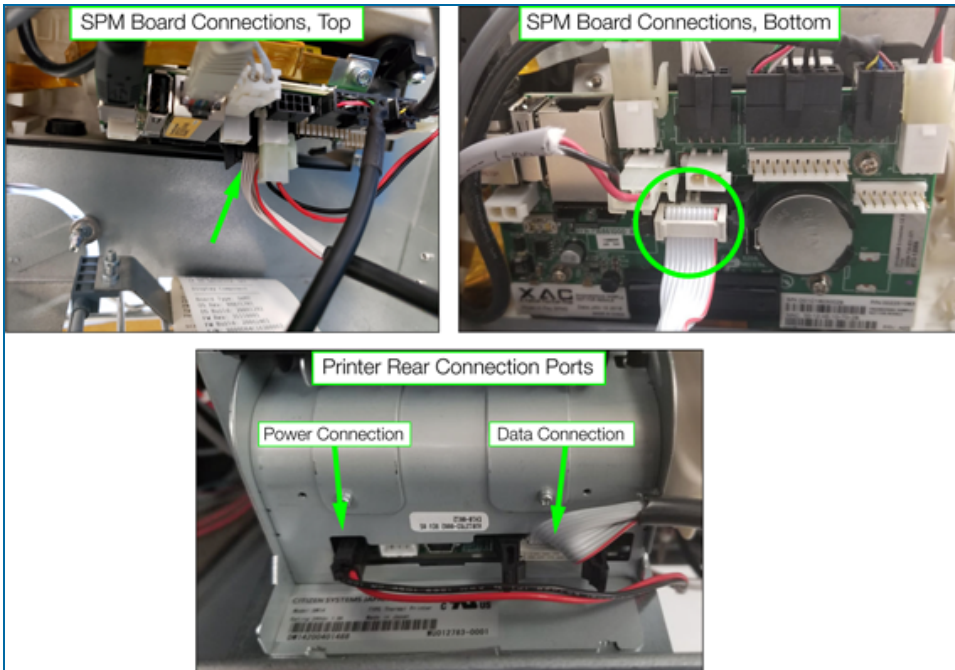

The top images above show the location of the 10-pin snap-in connector (marked J16 on the board). Connect the P7 end of the Data Cable to this connector. Make sure the red wire of the cable points to the right.

The printer connection ports are shown in the bottom photo above.

- Connect the P50 end of the Data Cable to the 10-pin snap-in connector on the right rear of the printer. Make sure the red wire points to the right.
- Connect the Power Cable to the power connector on the left rear of the printer.

Put the SPM cover back in position.

5.4.3 Install Paper

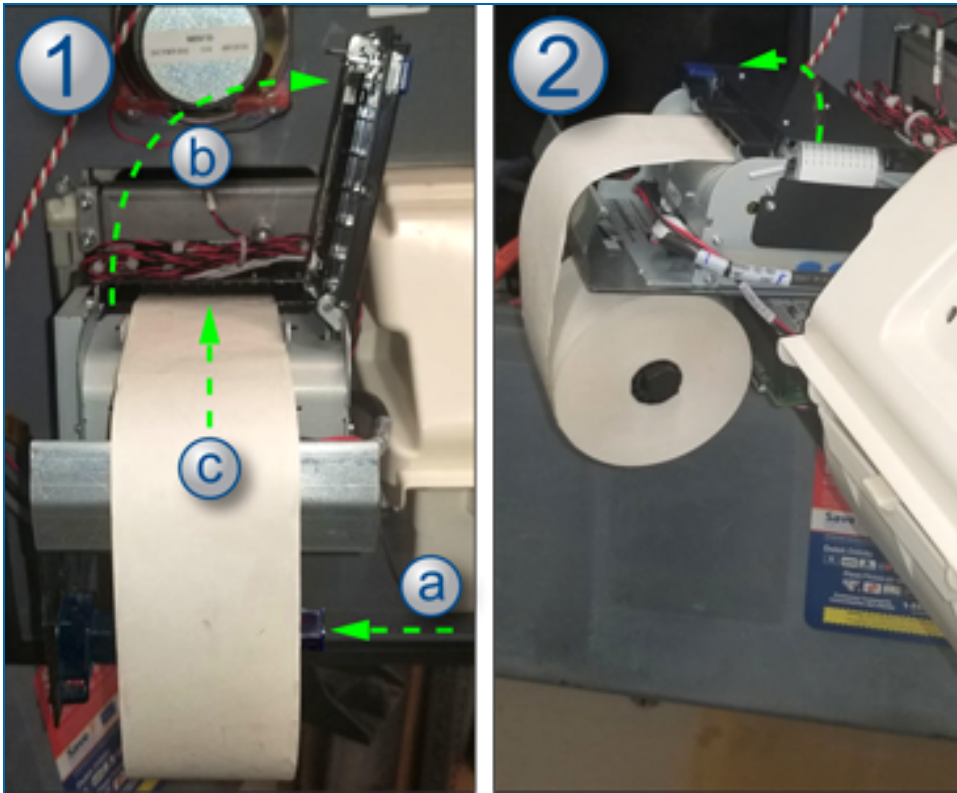

1. Install the paper roll.
 - a. Put the paper roll on the spindle. Make sure the paper is over the top of the roll.
 - b. Open the printhead.
 - c. Feed the paper through the printhead.
2. Close the printhead.

You can now close and lock the unit. Supply power to the terminal.

Section 6 Wiring

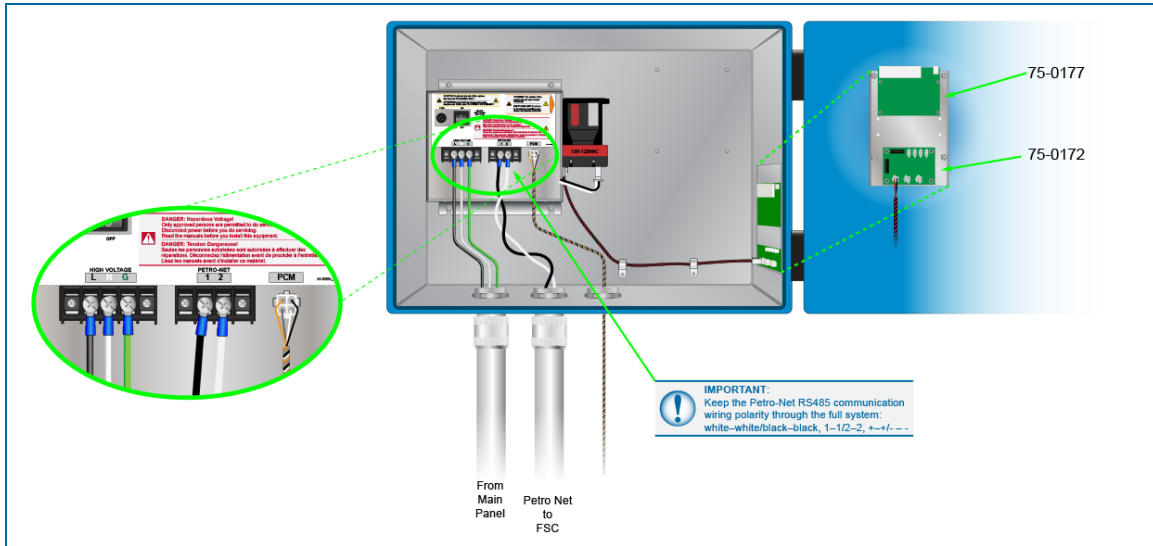

The illustration above shows the connections for power, communication and applicable Pump Control Modules (optional).

- Connect the power wires to the High Voltage terminal block as shown.
 - Black to Line
 - White to Neutral
 - Green to Ground
- Connect the Petro Net (RS485) wires to the Petro-Net terminal block.



IMPORTANT: Keep the Petro-Net RS485 communication wiring polarity through the full system: white-white/black-black, 1-1/2-2, + - / - -

- If PCMs are used, plug the 4-pin Molex connector into the PCM plug as shown.

All other internal connections are pre-wired at the factory.

For more information on Pump Control Module installation and operation, see [M00-20-0340 PCM Installation, Operation and Maintenance](#).



IMPORTANT: Pump Control Module (PCM) boards cannot be shipped with Division 2 specified PV300E terminals. Refer to ["Class I, Division 2, Group B and Group D Hazardous Area Installations" on page 6](#) for more information on DIV 2 installations with wireless radio and Pump Control Modules. Refer to [M00-20-0340 PCM Installation, Operation and Maintenance](#) for information on PCM remote enclosure and pedestal installation

Section 7 Complete the Installation

When the pedestal, terminal, conduit and wiring installations are done, you can complete the installation.



NOTICE: Do a check of the wiring before you apply power to the system components. Line (L) voltage applied to low-voltage inputs will damage the system.

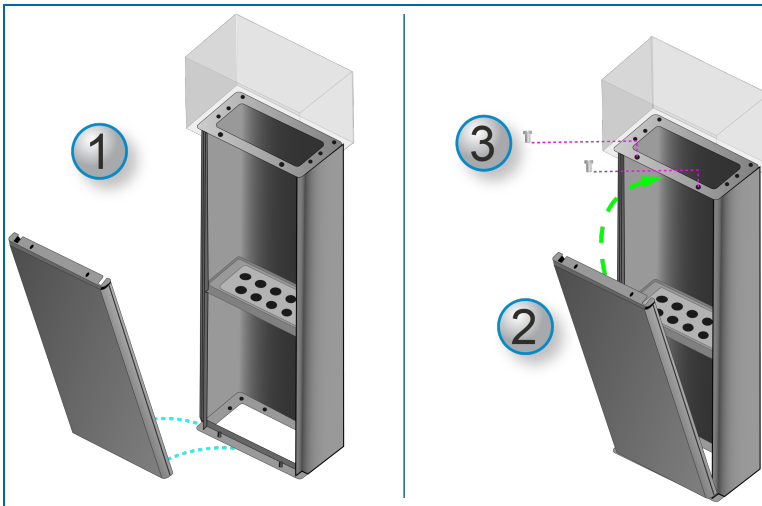

Install the pedestal door:

1. Put the two (2) holes in the bottom of the door over the door pins in the front of the pedestal base.
2. Move the top of the door into position as shown in the illustration.
3. Use the two (2) supplied hex bolts to assemble the door to the terminal as shown in the illustration. Make sure that the bolts are tight.

You can now energize the system.

Section 8 Maintenance

The PV300E Terminal is designed for years of trouble-free use. For maximum service life, it is recommended that the maintenance items that follow be done at regular intervals.

Cabinet and Door

Wipe down terminals with warm water, mild detergent (dish soap) and a non-abrasive cloth. To protect the finish of the Terminal cabinet and pedestal, a commercially available car wax can be applied.



IMPORTANT: DO NOT use a power washer or hose to rinse off the system!

Lexan Display Cover and Weather shield

Do not use petroleum-based cleaners or harsh detergents to clean the Lexan display Cover or Weather shield.

Keypad

Wipe down the keypad with warm water, mild detergent (dish soap) and a non-abrasive cloth. A damaged keypad should be replaced.

Door Locks

Lubricate door locks every six months, or as needed. Use graphite or molybdenum disulfide ("Moly-B") dry lubricant. Do not apply too much lubricant.

Heaters

Make sure the heater(s) work correctly during periods of cold weather.

Section 9 Optional Wireless Antenna Installation

P/N 20-7091 - PV300E Antenna Installation Kit



IMPORTANT: Wireless Terminal Radio installations are not permitted in a Class I, Division 2, Group B hazardous location. Refer to "[Class I, Division 2, Group B and Group D Hazardous Area Installations](#)" on page 6 for more information on DIV 2 installations with wireless radio and Pump Control Modules.

9.1 Terminal Radio Installation

DANGER: To prevent the possibility of electrical shock, de-energize the system before you do the procedure below.

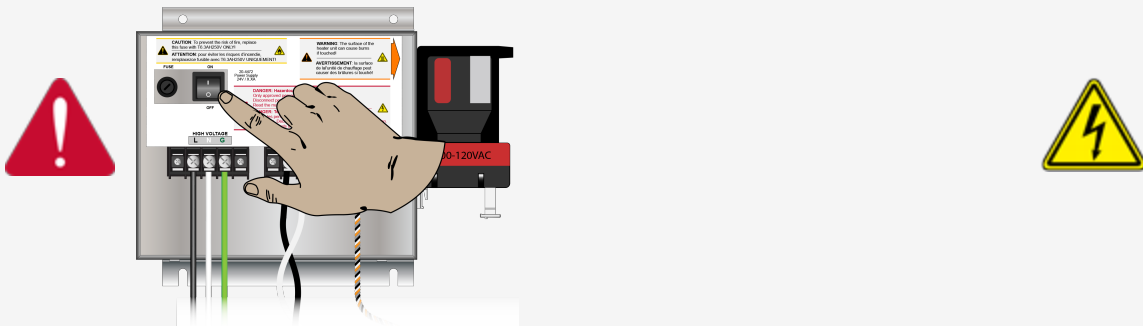

ATTENTION: Electrostatic Sensitive Device - To prevent damage to electrostatic sensitive components, wear a static dissipative strap when you install the antenna board assembly in the procedure that follows.

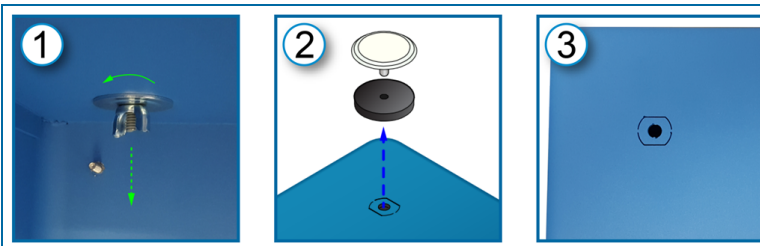

To install the AvalAN® antenna to the enclosure for wireless operation:

1. Loosen and remove the hole plug wing-nut and washer from the inside of the enclosure.
2. Remove the hole plug assembly from the knockout on the top of the enclosure.
3. Carefully punch out the knockout.



IMPORTANT: There can be two different antenna knockout types (see the image below). The revision 0 type ("double D") must be removed with a 7/8" Greenlee punch. The revision 1 type (circular) can be removed with a hammer and screwdriver.

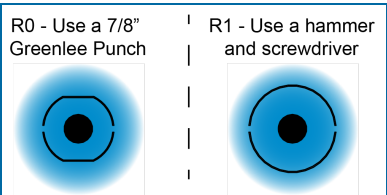

IMPORTANT: Make sure the knockout is punched out clean and that the top of the enclosure around the hole does not get bent. File the edges of the hole if necessary. Make sure the enclosure is clean and no filings remain in the bottom of the enclosure.

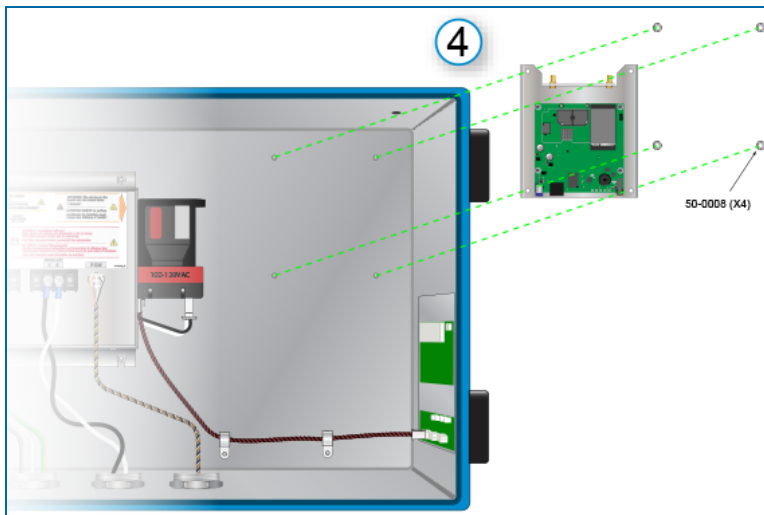

Install the board and bracket assembly:

4. Put the board and bracket assembly onto the four (4) threaded studs in the upper right corner on the back wall of the enclosure. Install the four (4) 50-0008 nuts and tighten them.

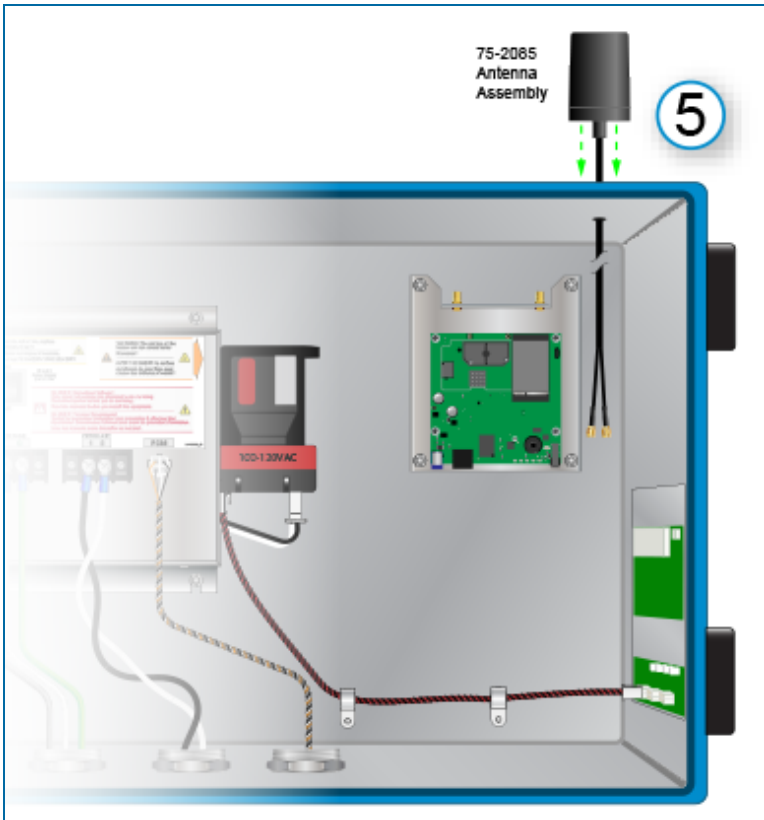

Install the antenna:

5. Put the wire leads of the antenna through the knockout hole. Put the bulkhead fitting part of the antenna through the hole so that the bottom of the antenna is flush with the top of the enclosure.



NOTE: If the bulkhead fitting part of the antenna does not go through the hole easily, use a file to increase the dimension of the hole sufficient for clearance. Be sure to clean the filings from the bottom of the enclosure.

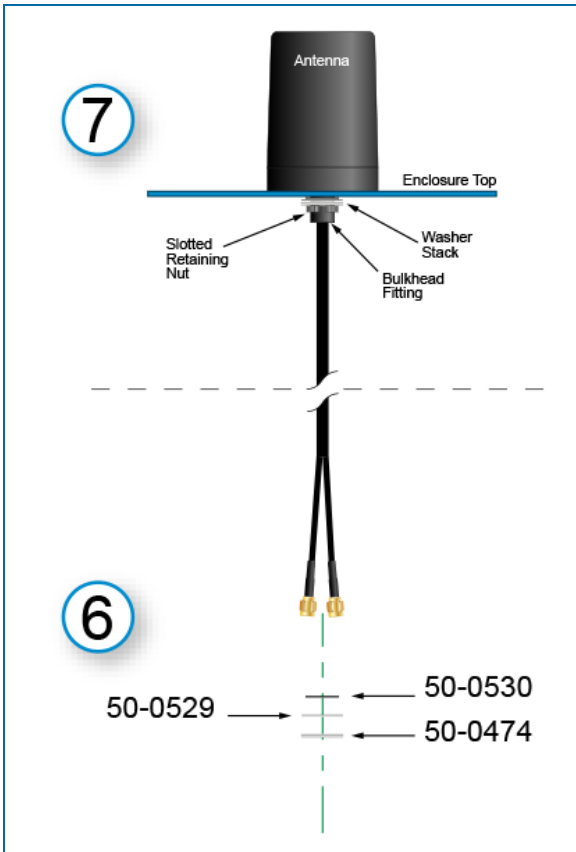

6. Put the wire leads, one at a time, through the three washers so they are in a stack in this order from top to bottom:
 - 50-0530 small plastic washer
 - 50-0529 large plastic washer
 - 50-0528 metal washer
7. Push the washer stack up so it is flush with the enclosure. Put the slotted nut (that came with the antenna assembly) onto the bulkhead fitting tightly under the washer stack and push until it clicks into position.

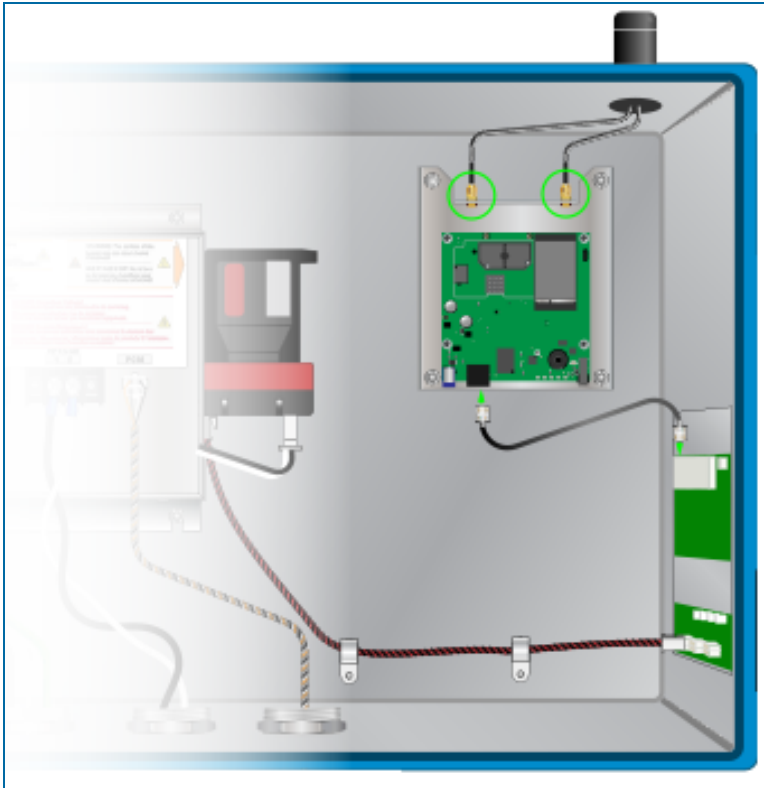

8. Attach the cable connectors of the antenna leads to the antenna connectors on the wireless radio board and bracket assembly (polarity is not important. Turn the connectors clockwise to tighten them.). Attach the 12-3005-18-BLK from the Ethernet connector of the Antenna board to Ethernet In & PoE port of the 5-Port Ethernet Switch (see the illustration below).

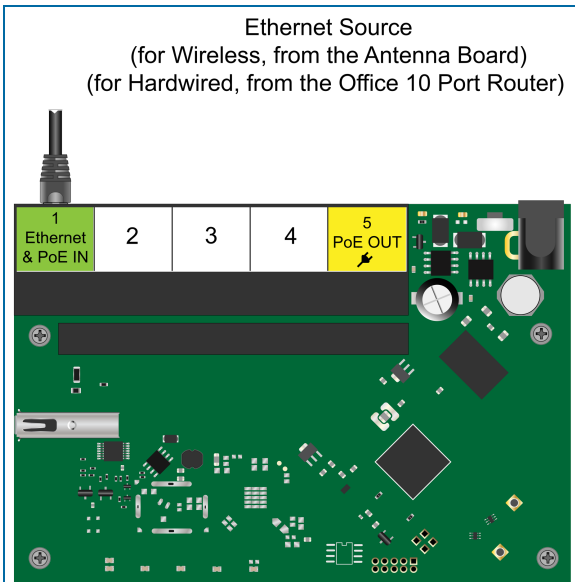

9.2 Access Point Installation

You must make a decision as to where your Access point unit should be installed:

The recommended installation is in a window that has a line-of-sight that is not blocked to the terminals where the internal antenna boards are installed.

As an alternative, the Access Point unit can be installed on a back wall of the office or store with a clear view to the terminals.

9.2.1 Window Installation (recommended)



IMPORTANT: The antennas must have a clearance of at least two (2) inches.

1. Clean the surface area of the window where the unit will be installed. Make sure the area is clean and dry before you go to the next step.



2. Remove the backing from one side of the adhesive pad. Install the pad on the flat side of the antenna bracket as shown in the photo above.
3. Remove the adhesive from the other side of the adhesive. Put the bracket on the cleaned area window. Apply pressure and hold it in position for 10-15 seconds to let the adhesive bond correctly to the glass.
4. Assemble the antennas to the Access Point unit.
5. Connect one end of an Ethernet (Cat 6 recommended) cable to the Ethernet port of the AvaLAN Access Point.



NOTE: The cable length must be a maximum of 300 feet (100 m).

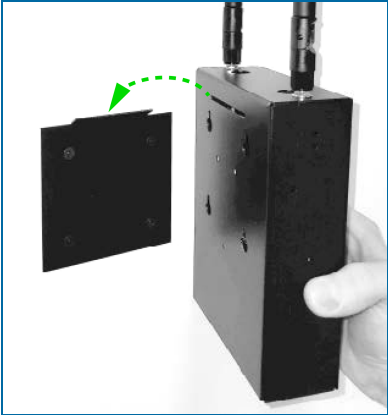

6. Put the horizontal slot on the back of the Access Point over the lip of the bracket (refer to the photo above). Push down to put the Access Point in position.
7. Connect the other end of the Ethernet cable to the RJ45 jack of the AW-PoE Power Over Ethernet Injector (included).
8. Connect the RJ45 connector of the AW-PoE injector to an open LAN port of your system's TP Link router.
9. Connect the P5 socket connector of the AW-PoE adapter to the external power supply (included).
10. Connect the 24 VDC power supply to a 120 VAC outlet. A green LED on the PoE injector will come on to show that power has been applied.
11. Connect the P5 socket connector of the AW-POE adapter to the external power supply (included).

9.2.2 Wall Installation

To install the unit on a wall, replace steps 1 - 3 above with the procedure that follows.

- Use four (4) screws applicable to the wall material (not included).
- Drill guide holes and anchors as necessary (use the hole pattern of the bracket as a guide).
- Install the screws through the four (4) holes of the bracket. Make sure the bracket lip points out.

9.2.3 Pair the Access Point with the Terminal Radios

1. Make sure that each of the terminal units' power supplies are on. Make sure you have the terminal radio Pairing Keys ready.
2. Apply power to the Access Point and wait a minimum of 45 seconds.
3. Put the Access Point's Pairing Key into the USB port of the Access Point. Wait for the confirmation tone (beep).

4. **Within 15 seconds**, remove the Access Point key and put the first terminal radio's Pairing Key into the Access Point USB port. Wait for up to 30 seconds for the confirmation tone (beep).
5. Repeat steps 3 and 4 for each of the terminal radio Pairing Keys.



NOTE: If the pairing procedure is unsatisfactory, you will hear a failure tone. Remove the terminal radio's Pairing Key. Make sure the terminal radio is on. Repeat steps 3 and 4 until you hear the confirmation tone.



IMPORTANT: Keep the Pairing Keys together in a safe location so they can be easily found if necessary.

Appendix A - Component Connections

Typical Site External Component Connections

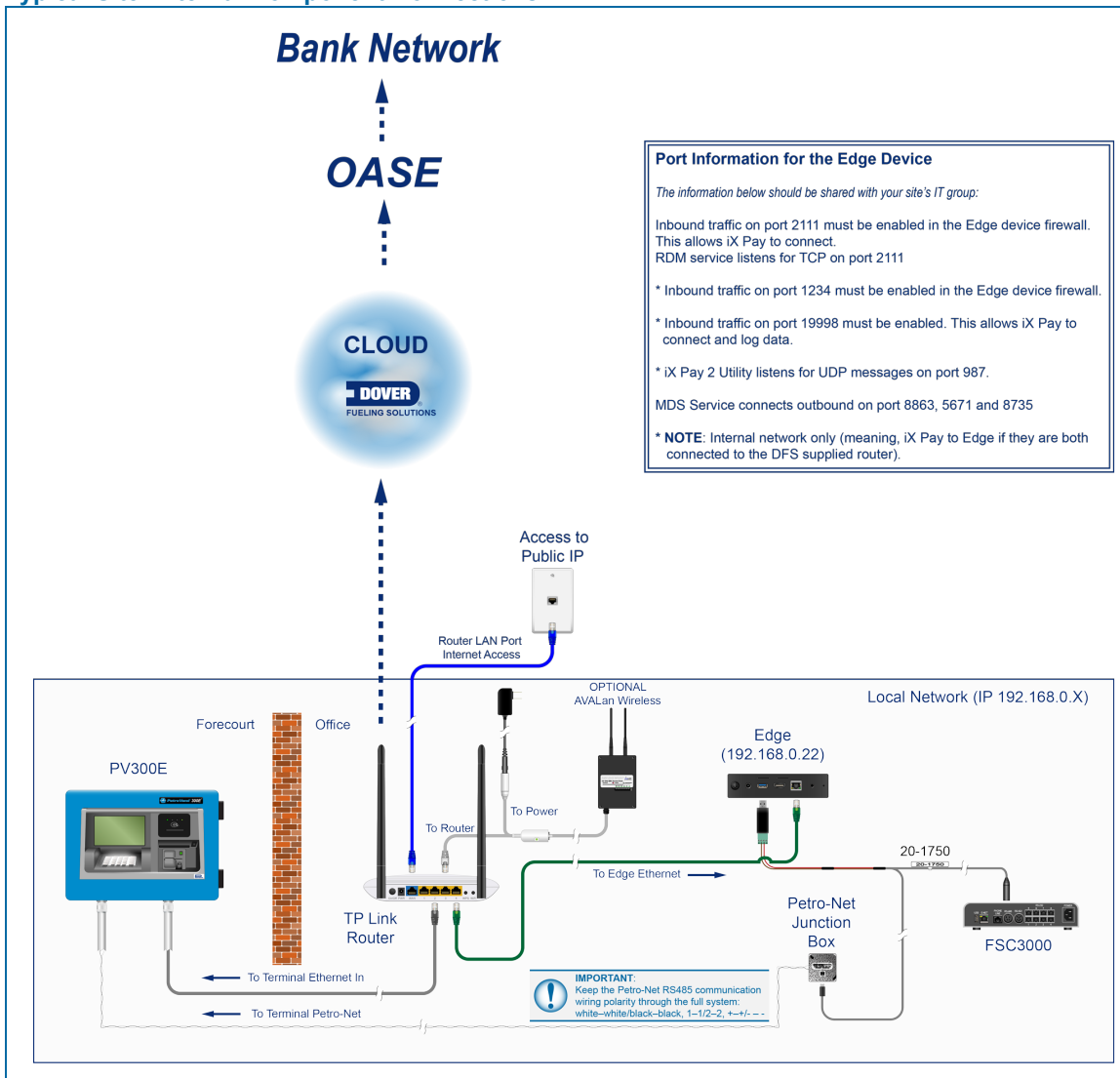

- Use the 20-1750 "Y" cable to connect:
 - Barrel connector to the FSC3000 RS485 port.
 - RS485 to USB adapter connector to an open USB port on the Edge
 - Petro-Net connector to the Petro-Net Junction Box.
- Connect an Ethernet cable from your Internet access to the TP Link Router WAN port.
- Connect an Ethernet cable from an open TP Link LAN port to the Edge Ethernet port.

- Connect an Ethernet cable from an open TP Link Wan port to the left port of the terminal's router board port block. See ["Wiring" on page 42](#) for more information on terminal wiring.



IMPORTANT: The Ethernet cable must be installed in the terminal when the power and Petro-Net wiring is installed. It is recommended to use a dedicated conduit for this cable.



INFORMATION: See ["Wiring" on page 42](#) for more information on terminal wiring.

- Connect Petro-Net wiring from the Petro-Net Junction Box to the terminal's Petro-Net terminal block.



IMPORTANT: The Petro-Net wiring must be installed in the terminal when the power and Ethernet wiring is installed. It is recommended to use a dedicated conduit for this wiring.



NOTE: Keep the Petro-Net RS485 communication wiring polarity through the full system: white–white/black–black, 1–1/2–2, +–+/- – –



INFORMATION: See ["Wiring" on page 42](#) for more information on terminal wiring.

Optional AvaLAN Wireless Connection

If the optional AvaLAN Wireless Access Point is installed, connect the included Power Injector adapter:

- Connect one end of an Ethernet (Cat 6 recommended) cable to the Ethernet port of the AvaLAN Access Point.



NOTE: The cable length must be a maximum of 300 feet (100 m).

- Connect the other end of the Ethernet cable to the RJ45 jack of the AW-PoE Power Over Ethernet Injector (included).
- Connect the RJ45 connector of the AW-PoE injector to an open LAN port of your system's TP Link router.
- Connect the P5 socket connector of the AW-PoE adapter to the external power supply (included).
- Connect the 24 VDC power supply to a 120 VAC outlet. A green LED on the PoE injector will come on to show that power has been applied.



INFORMATION: Refer to "[Optional Wireless Antenna Installation](#)" on page 46 for more information about the AvaLAN wireless option.

Appendix B - Door Removal and Assembly

If it becomes necessary to remove the door assembly to do maintenance work do the procedure that follows.



INFORMATION: Refer to the instructions in M1024-MM PV300E Maintenance Mode. When the terminal has been put in Maintenance Mode, put the Power Supply switch in the OFF position to de-energized the system.

WARNING: De-energize the Terminal before you do this procedure! Push the Terminal rocker switch on the Power Supply to the O position.

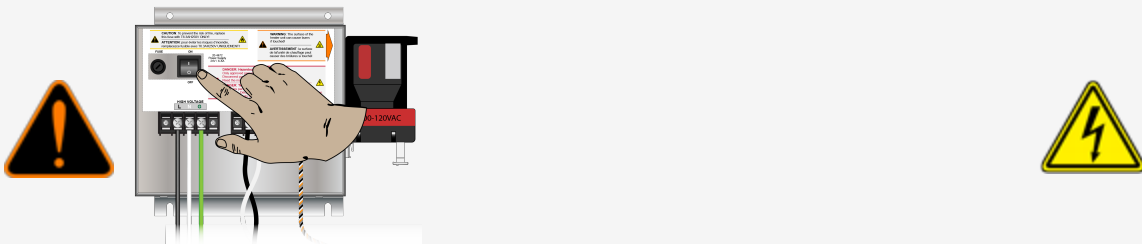

Make sure all electrical power from the main breaker is OFF before you do the procedure below!

Door Assembly Removal

- Unlock and open the **door** of the unit.

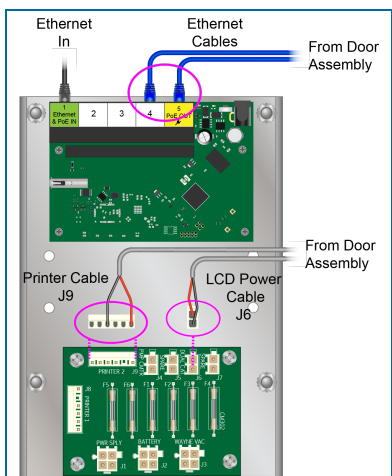

- Disconnect the wiring from the door assembly (refer to the illustration above):
 - Disconnect the two (2) blue **Ethernet cables** from the Five-port Router Board. The board is installed along the right side inner wall of the enclosure.
 - Disconnect the **LCD Power Cable** from the J6 connector socket of the Fuse Board. The Fuse Board is installed along the right side inner wall of the enclosure below the Five-port Router Board.
 - Disconnect the **Printer Cable** from the J9 connector socket of the Fuse Board.

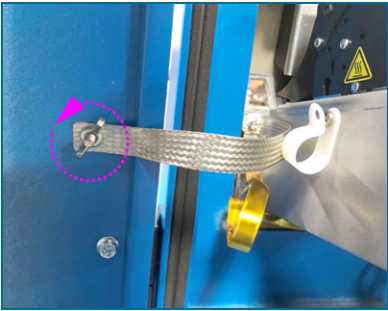

- Turn the **wing nut** that holds the Ground Strap counterclockwise to remove the nut and the strap from the ground post. Put the wing nut back on the post. You will use it to connect the Ground Strap again when the door is put back on the enclosure.

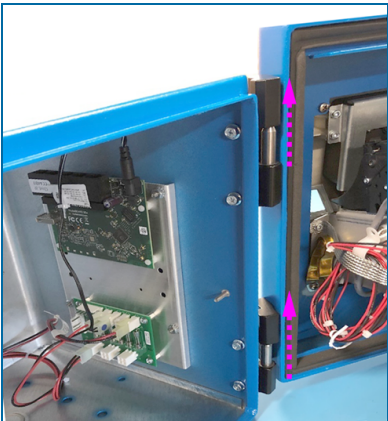

- Carefully lift the Door Assembly straight up so that the hinges are fully disconnected.
- Maintenance can now be done.



NOTE: Put a tarp or other cover over the open enclosure to keep out dirt, dust or other unwanted material.

Assemble the Door to the Enclosure

When maintenance is complete, do the procedure that follows to assemble the Door to the Enclosure.

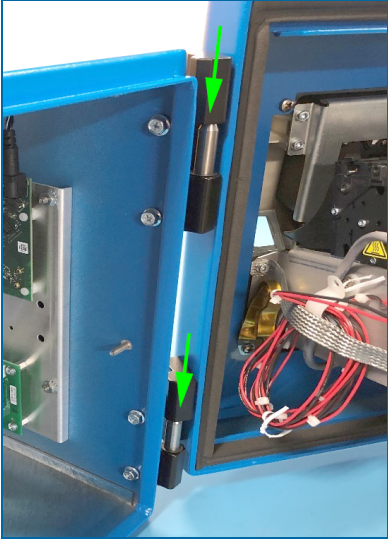

Align the hinges of the Door Assembly with the hinge pins of the enclosure. Carefully lower the Door Assembly over the pins.

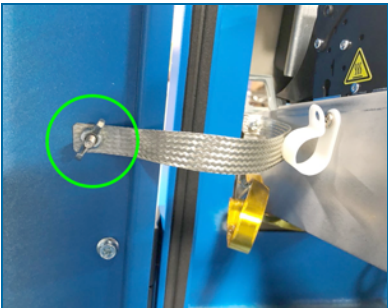

Remove the wing nut from its post in the side of the Enclosure. Put the hole of the ground strap over the post. Put the wing nut back on the post and tighten it.

Connect the Door Assembly Wires

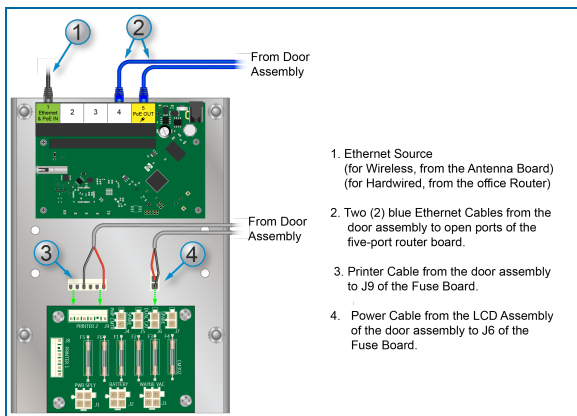

1. Connect the Ethernet Source. The port farthest to the left of the Five-Port Router inside the enclosure (along the right wall) is the Ethernet In port. Use an Ethernet cable to connect the Ethernet source to this port as shown in the illustration.
 - If your Source is from the optional Antenna connect as shown in ["Optional Wireless Antenna Installation"](#) on page 46.
 - If your source is hardwired, the routing of the Ethernet cable should be from the Router inside the office.
2. Connect the two (2) blue Ethernet cables from the Door Assembly to two (2) of the open ports of the Five-Port Router Board as shown in the illustration.
3. Connect the Printer Cable from the Door Assembly to the J9 connector of the Fuse Board as shown in the illustration.
4. Connect the LCD Assembly Power Cable from the Door Assembly to the J6 connector of the Fuse Board as shown in the illustration.

Put the Terminal Back in Operational Mode



WARNING: To prevent dangerous conditions, make sure that it is safe to supply power to the unit when maintenance work is completed.



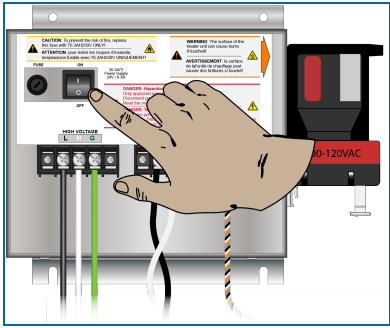

- Put the Power Supply switch in the ON position to energized the system.
- Close and lock the door.



INFORMATION: Refer to the instructions in [M1024-MM PV300E Maintenance Mode](#) for instructions on how to put the terminal back in Operational Mode.

Appendix C - Service Technician Tools

For Service Technicians: The tools in the list that follows are required for all service calls:

- HDMI Cable
- HDMI Monitor
- Keyboard and Mouse

Revisions FMM1020

<i>Revision #</i>	<i>ECO</i>	<i>Effective</i>	<i>Software Version</i>	<i>Key Changes</i>
0	1769	6/29/2020	N/A	Initial Release
1	1847	1/22/2021		Aluminum enclosure conduit knock-outs, additional pedestal dimensions, Complete the Installation section, receipt printer installation, AVAAn radio installation, Component Connections Appendix, Door Removal and Assembly Appendix, Tech Service Tools Appendix
2	2048	6/22/2022		Citizen Printer installation and replacement.
2.1	PN	5/18/2023		Add pedestal height dimension illustration.
3	EC20468	1/30/2024		Class I, Division 2, Group B & D installations, update heading formats. UL verbiage correction.



NOTE: It is possible that older software versions might not support all features

Warranty

OPW Fuel Management Systems warrants that all OPW Tank Gauge and Petro Vend Fuel Control systems supplied by OPW Fuel Management Systems to the Original Purchaser will be free from defects in material and/or workmanship under normal use and service for a period of 12 months from the date of installation or 15 months from the date of shipment from OPW. Additionally, OPW Fuel Management Systems warrants that all upgrades and replacement parts (new and remanufactured) supplied by OPW Fuel Management Systems will be free from defects in material and workmanship under normal use and service for a period of 90 days from the date of installation or for the remainder of the system's original warranty, whichever is greater, as set forth in the first sentence of this statement. The foregoing warranties will not extend to goods subjected to misuse, neglect, accident, or improper installation or maintenance or which have been altered or repaired by anyone other than OPW Fuel Management Systems or its authorized representative. The buyer's acceptance of delivery of the goods constitutes acceptance of the foregoing warranties and remedies, and all conditions and limitations thereof.

If a claim is made within the warranted time period that any equipment and/or remanufactured part is defective in material or workmanship under normal use and service, such equipment and/or remanufactured part shall be returned to OPW Fuel Management Systems, freight prepaid. If such equipment or remanufactured part is found by OPW Fuel Management Systems in its sole judgment to be defective in material or workmanship under normal use and service, OPW Fuel Management Systems shall, at its sole option, repair or replace such equipment and/or remanufactured part (excluding, in all instances, fuses, ink cartridges, batteries, other consumable items, etc.) OPW Fuel Management Systems shall not be held responsible for data loss or retrieval on returned products.

The warranties, as set forth above, are made expressly in lieu of all other warranties, either expressed or implied (including, without limitation, warranties of merchantability and fitness for any particular purpose and of all other obligations or liabilities on OPW Fuel Management Systems' part.) Further, OPW Fuel Management Systems neither assumes, nor authorizes any other person to assume for it, any other liability in connection with the sale of the systems, or any new/replacement part that has been subject to any damage from any act of nature or any force majeure. Any terms proposed by the Original Purchaser either orally or in writing are expressly rejected. The terms and conditions expressed in this document may only be changed upon the express written consent of OPW Fuel Management Systems.

The term "Original Purchaser" as used in these warranties shall be deemed to mean the authorized OPW Fuel Management Systems' distributor to which the system or any new/replacement part was originally sold. These warranties may be assigned by the original purchaser to any of its customers who purchase any OPW Fuel Management Systems' systems or new/replacement parts. This document shall be governed by and construed in accordance with the law of the State of Illinois. OPW Fuel Management Systems and Original Purchaser agree that any legal action or proceeding under or with respect to this document may ONLY be brought in the courts of the State of Illinois, or the United States District Court having jurisdiction in the City of Hodgkins, Illinois. Original Purchaser expressly consents to personal jurisdiction in any of the above-mentioned forums and agrees to waive all defenses based on improper venue or inconvenient form should an action be brought therein.

The sole liability of OPW Fuel Management Systems, for any breach of warranty, shall be as set forth above. OPW Fuel Management Systems does not warrant against damage caused by accident, abuse, faulty or improper installation or operation. In no event shall manufacturer's liability on any claim for damages arising out of the manufacture, sale, delivery or use of the goods exceed the original purchase price of the goods. In no event shall OPW Fuel Management Systems be liable for any direct, indirect, incidental or consequential damage or loss of product.

TERMS

Ex-works our factory, Hodgkins, Illinois, USA

Installation not included.

All trade names are registered. Patents pending.

Subject to engineering improvement and/or other changes.

