



THERE'S THE OLD WAY... OR THERE'S THE

THE SITESENTINEL® iSITE™ AST FLEX PROBE

Leading the way in AST inventory monitoring

Until now, monitoring of products in above-ground storage tanks has been inaccurate at best. Many AST tank gauging devices are available, but none have the precision and accuracy of OPW's SiteSentinel® iSite™.

The 7100V Series flexible probe uses field proven magnetostrictive technology to allow greater precision and reliability. This probe is ideal for liquid level monitoring of product and water levels in a wide variety of liquids in above ground storage tanks, including gasoline, diesel, ethanol, biodiesel, lubricants and some chemicals.



Part of the
SiteSentinel®
family of products



INTEGRATED

All probe electronics are integrated into the sensing tube, eliminating the bulky enclosure at the top of the probe and offering greater options for installation and mounting in aboveground storage tanks.



ACCURATE

OPW's NEW SiteSentinel® iSite™ uses proven magnetostrictive technology that accurately measures product level changes to a resolution of .010".

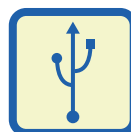

INSTALLATION

The flexible PVDF probe comes coiled with a threaded fitting on the end of the probe which allows for ease of installation.



INNOVATIVE

OPW's new water float can detect a minimum of 2-1/2" of water in the bottom of a tank, ensuring product quality.



Specifications

- Input Voltage: 23–28 VDC
- Tank Probe: Flexible PVDF to a max. of 5' (15.15m)
- Enclosure: Material PVDF
- Resolution: 0.010" Inventory Mode
- Linearity: +/- 0.01% of Full Scale, +/- 0.010" (.254mm), whichever is greater
- Repeatability: +/- 0.001% of Full Scale, +/- 0.00025" (.00635mm), whichever is greater
- Temperature Accuracy: Absolute +/- 2° F (1.11o C)
- Temperature Measurement Resolution: +/- 0.01° F (.02° C)
- Temperature Sensing Range: -40° F to +150° F (-40° C to +65° C)
- Operating Temperature Range: -40° F to +160° F (-40° C to +71° C)
- Water Float Lift-Off: 2-1/2" at 70° F (21° C)
- Distance to VSmart Module: Up to 1000' using twisted-pair wire
- Environment: NEMA 4
- Listings: UL, Intrinsically Safe
- Maximum Tank Capacity: 99,999,999 gallons (99,999,999 liters)



Probe Length Availability

The flexible AST magnetostrictive probe is available in lengths from 24" to 600." Reference the following for ordering information:

- 193" (16') to 216" (18') 490cm (4.84m) to 548cm (5.45m)
- 217" (18') to 240" (20') 551cm (5.45m) to 609cm (6.06m)
- 241" (20') to 264" (22') 612cm (6.06m) to 670cm (6.66m)
- 265" (22') to 288" (24') 673cm (6.66m) to 731cm (7.27m)
- 289" (24') to 312" (26') 734cm (7.27m) to 792cm (7.87m)
- 313" (26') to 336" (28') 795cm (7.87m) to 853cm (8.48m)
- 337" (28') to 360" (30') 855cm (8.48m) to 914cm (9.09m)
- 361" (30') to 384" (32') 916cm (9.09m) to 975cm (9.69m)
- 385" (32') to 396" (33') 977cm (9.69m) to 1005cm (10m)
- 397" (33') to 408" (34') 1008cm (10m) to 1036cm (10.3m)
- 409" (34') to 420" (35') 1038cm (10.3m) to 1066cm (10.6m)
- 421" (35') to 432" (36') 1069cm (10.6m) to 1097cm (10.9m)
- 433" (36') to 444" (37') 1099cm (10.9m) to 1127cm (11.21m)
- 445" (37') to 456" (38') 1130cm (11.21m) to 1158cm (11.51m)
- 457" (38') to 468" (39') 1160cm (11.51m) to 1188cm (11.81m)
- 469" (39') to 480" (40') 1191cm (11.81m) to 1219cm (12.12m)
- 481" (40') to 492" (41') 1221cm (12.12m) to 1249cm (12.42m)
- 493" (41') to 504" (42') 1252cm (12.42m) to 1280cm (12.72m)
- 505" (42') to 516" (43') 1282cm (12.72m) to 1310cm (13.03m)
- 517" (43') to 528" (44') 1313cm (13.03m) to 1341cm (13.33m)
- 529" (44') to 540" (45') 1343cm (13.33m) to 1371cm (13.63m)
- 541" (45') to 552" (46') 1374cm (13.63m) to 1402cm (13.93m)
- 553" (46') to 564" (47') 1404cm (13.93m) to 1432cm (14.24m)
- 565" (47') to 576" (48') 1435cm (14.24m) to 1463cm (14.54m)
- 577" (48') to 588" (49') 1465cm (14.54m) to 1493cm (14.84m)
- 589" (49') to 600" (50') 1496cm (14.84m) to 1524cm (15.15m)

Certification

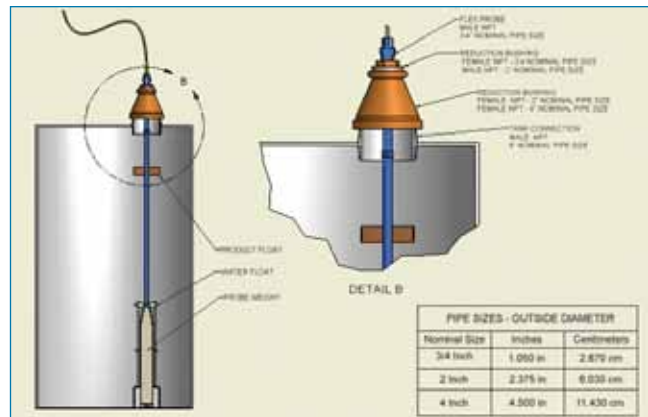
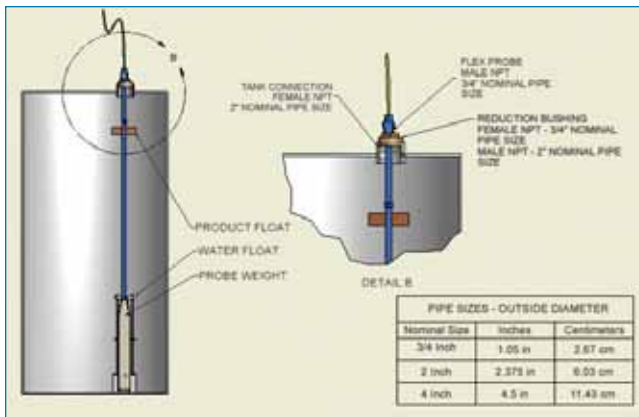

Flex Probe Installations Using Pipe Fittings



ONE COMPANY. ONE WORLD. ONE SOURCE.

6900 SANTA FE DRIVE • HODGKINS, IL USA 60525 • www.opwfmts.com • 708-485-4200 • (fax) 708-485-4630

NOTE: All information subject to engineering and/or other changes. All trade names are copyrighted. Patents Pending. ©2008 OPW Fuel Management Systems
©2008 Delaware Capital Formation, Inc. All Rights Reserved. DOVER and the DOVER logo are registered trademarks of Delaware Capital Formation, Inc., a wholly-owned subsidiary of Dover Corporation