

SIZE	3"	4"	COMMENTS
A	8"	9"	
D	3"	3"	
E	7-1/2"	9"	
F	6"	7-1/2"	
G	4 (3/4")	8 (3/4")	
H	5"	6-3/16"	
J	13/16"	1"	
K (SHIELD HT.)	9/16"	9/16"	
WEIGHT (LBS)	29.3	35	

PARTS LIST			
PART NO.	NAME OF PART	QTY	MATERIAL
1	BODY	1	SEE BELOW
2	O-RING SEAL	2	SEE BELOW
3	GLASS	2	STD
4	SHAFT SUPPORT	1	SST
5	INDICATOR	1	SEE BELOW
6	PROPELLER SHAFT	1	SST
7	TEFLON BUTTON	1	---
8	CAP PLATED STL	2	STL
9	SST TAG	1	SST
10	GASKET	2	NON ASBESTOS
11	SHIELD (OPTIONAL)	1	PLEXIGLASS

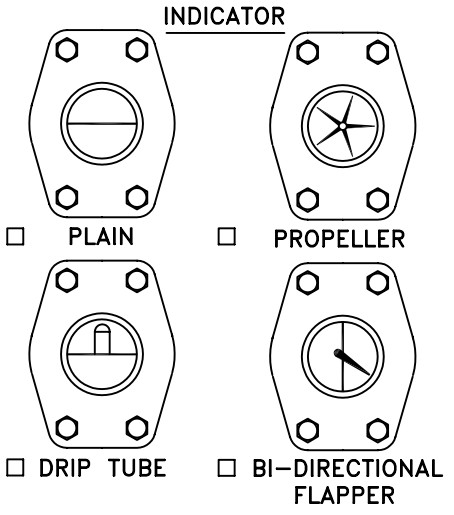

**STANDARD DESIGN MATERIALS:**

- SERIES OF UNIT:**  1500 (TEMPERED BOROSILICATE GLASS, TEFLON INDICATOR STND.)  
 1400 (ANNEALED BOROSILICATE GLASS, TEFLON INDICATOR STND.)
- METAL:**  ASTM A216 WCB CARBON STEEL  
 ASTM A351 316L STAINLESS STEEL
- OPTIONS:**  SHIELD KIT      **SEAL MATERIAL:**  VITON (1500 STD)  
 BUNA-N  
 NEOPRENE (1400 STD)  
 EPT  
 TEFLON

SERVICE RATINGS	MAX .PRESSURE	MAX. TEMP 1
1400 SERIES FLGD (6"-12")	150 PSI @250°F	250°F @150 PSI
1400 SERIES THRD/FLG (1/4"-4")	200 PSI @150°F	250°F @150 PSI
1500 SERIES FLGD (1"-12")	275 PSI @100°F	350°F @215 PSI
1500 SERIES THRD (1/4"-2")	400 PSI @150°F	350°F @200 PSI

1 STD NEOPRENE SEALS FOR 1400 SERIES AND VITON SEALS FOR 1500 SERIES.  
2 STL UNITS RATED @ 285 PSI MAX. @ 100°, & 350° MAX. @215 PSI  
3 TEMPERATURES UP TO 500°F POSSIBLE WITH SPECIAL HIGH TEMPERATURE SEALS (CONSULT FACTORY)

**FLANGED VISI-FLO SFI**

**Engineered Systems**

PH: 1-800-547-9393      5-12-2008  
FAX: 1-800-245-8536