

THIS DRAWING IS NOT TO BE SCALED. FOR ADDITIONAL INFORMATION, PLEASE CONTACT OUR ENGINEERING DEPT.

REVISIONS					
LTR	ECN #	DESCRIPTION	DRAWN	APPROVED	DATE
REL	41360	INITIAL RELEASE	SCK	NAC	10/13/03

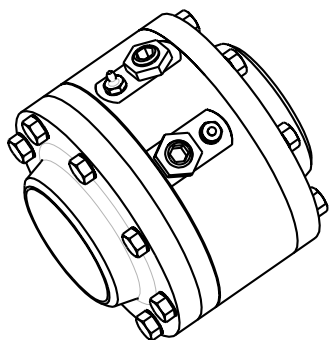

SCALE 0.350

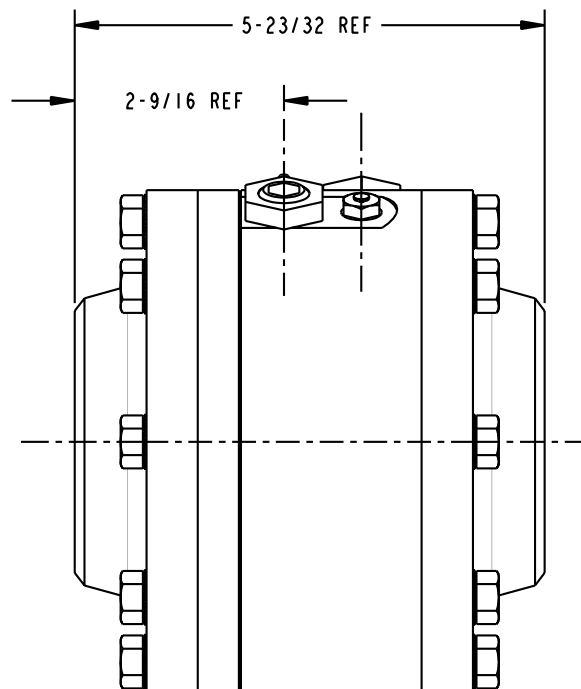
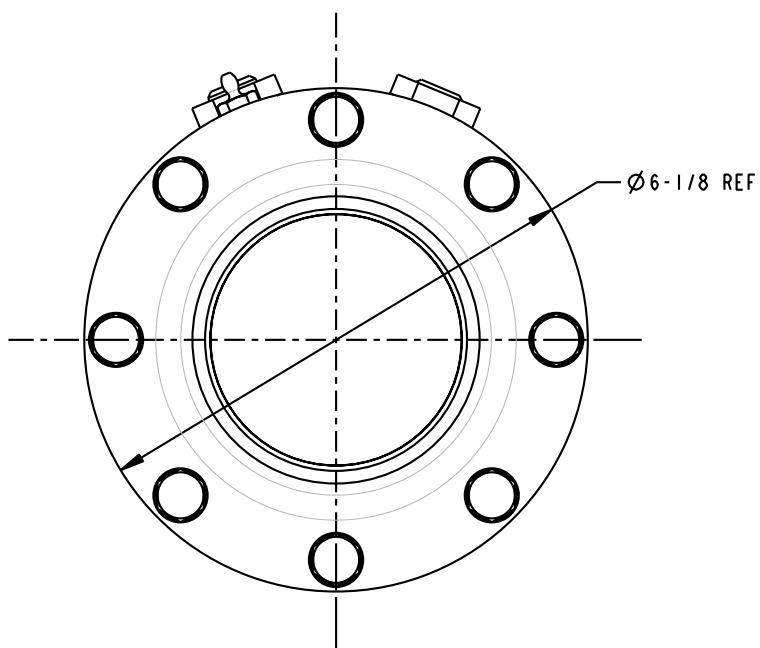

NOTES:

1. AIR TEST @ 5 psi & 70 psi, OR HYDROSTATIC TEST PER CUSTOMER SPECIFICATION.
2. MAXIMUM PRESSURE 500 psi.

CONFIDENTIAL THIS DOCUMENT CONTAINS INFORMATION WHICH IS PROPRIETARY TO OPW, AND SHOULD BE PROTECTED ACCORDINGLY.		DESCRIPTION: SWIVEL, 3" DSF STYLE 20W	
UNLESS OTHERWISE SPECIFIED TOLERANCES ON DIMENSIONS 3 DECIMALS +/- 0.005 2 DECIMALS +/- 0.015 1 DECIMAL +/- 0.030 ANGLES +/- 1/2 DEG MACHINED SURFACES 125 RMS MAX		SIGNATURES	MO-DA-YR
DRAWN: SCK		09/25/03	
CHECKED: NAC		10/13/03	
MATERIAL: -		WEIGHT: 25 lbs.	REV: REL
		SIZE: C	PART NUMBER: 8X20W-030X
		SCALE: 0.650	SHEET 1 OF 1
		3D GENERATED DRAWING	

OPW **Engineered Systems**
A **DOVER** Resources Company
Lebanon, Ohio 45036 USA