

A

B

C

D

THIS DRAWING IS NOT TO BE SCALED. FOR ADDITIONAL INFORMATION. PLEASE CONTACT OUR ENGINEERING DEPT.

REVISIONS				DRAWN	APPROVED	DATE
LTR	ECN #	DESCRIPTION				
-	-	-	-	-	-	-

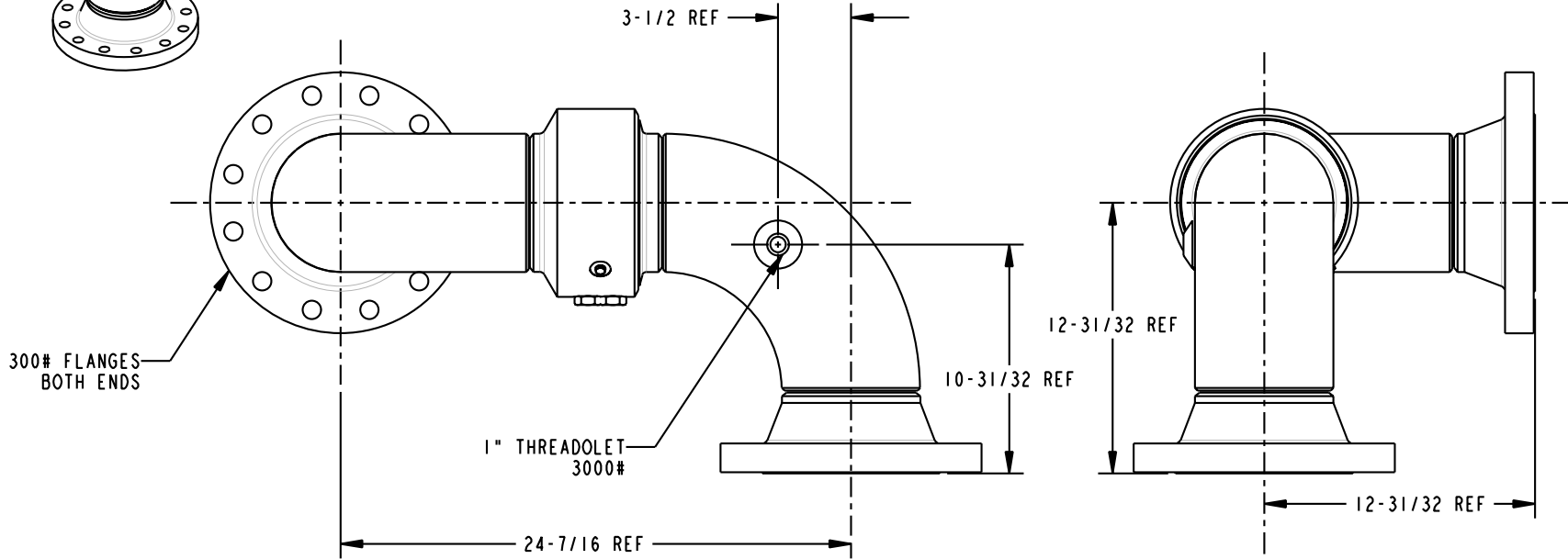
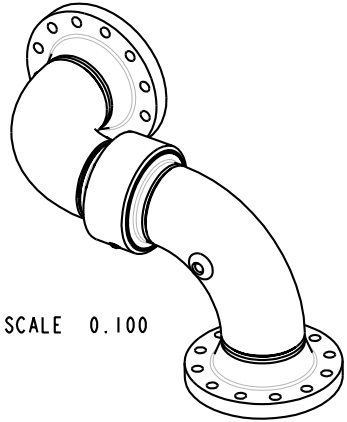

CONFIDENTIAL THIS DOCUMENT CONTAINS INFORMATION WHICH IS PROPRIETARY TO OPW, AND SHOULD BE PROTECTED ACCORDINGLY.

DESCRIPTION: 6" SWIVEL, CST, TFE, 300# FLGS

UNLESS OTHERWISE SPECIFIED
 TOLERANCES ON DIMENSIONS
 3 DECIMALS +/- 0.005
 2 DECIMALS +/- 0.015
 1 DECIMAL +/- 0.030
 ANGLES +/- 1/2 DEG
 MACHINED SURFACES 125 RMS MAX

SIGNATURES		MO-DA-YR	REV:
DRAWN:	SCK	06/30/05	-
CHECKED:	-	-	-
MATERIAL:	-	WEIGHT:	-

PART NUMBER:
3445F3-0603
SCALE: 0.180

OPW Engineered Systems
 A **DOVER** Resources Company
 Lebanon, Ohio 45036 USA

C SHEET 1 OF 1 3D GENERATED DRAWING

A

B

C

D