

A

B

C

D

THIS DRAWING IS NOT TO BE SCALED. FOR ADDITIONAL INFORMATION. PLEASE CONTACT OUR ENGINEERING DEPT.

REVISIONS				DRAWN	APPROVED	DATE
LTR	ECN #	DESCRIPTION				
-	-	-	-	-	-	-

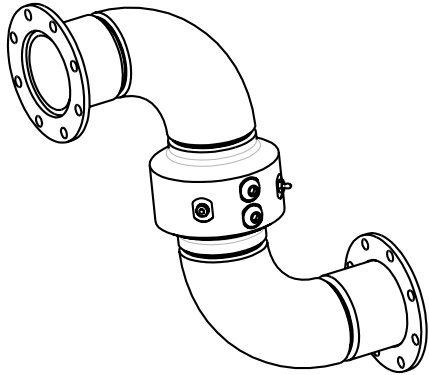

3" TTMA FLANGE BOTH ENDS

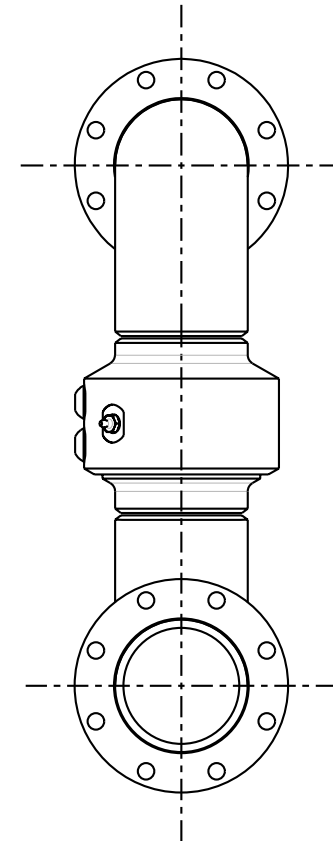
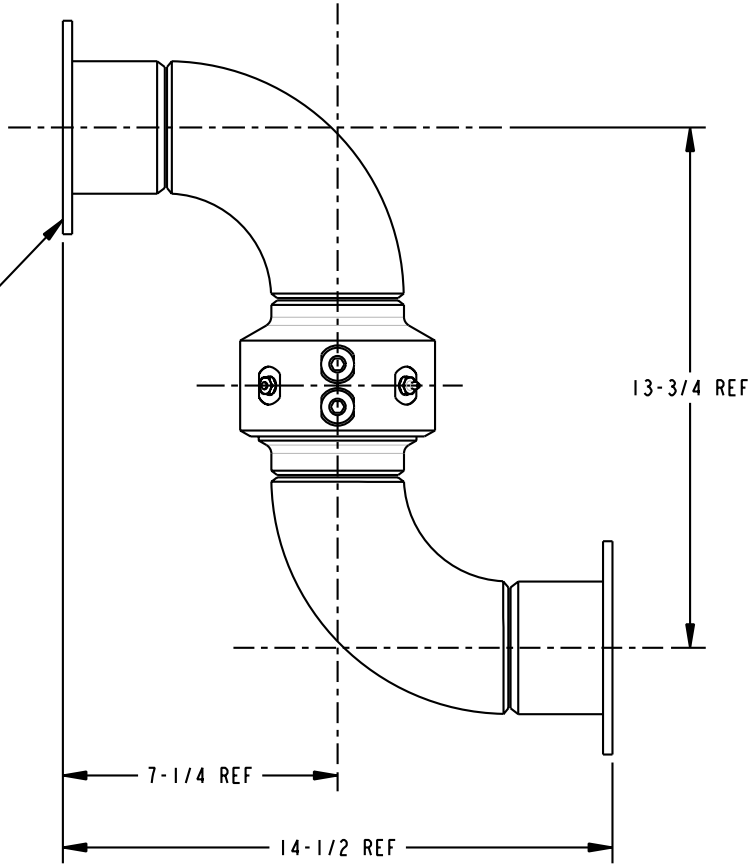

CONFIDENTIAL THIS DOCUMENT CONTAINS INFORMATION WHICH IS PROPRIETARY TO OPW, AND SHOULD BE PROTECTED ACCORDINGLY.

DESCRIPTION: 3" SWIVEL, CST, STYLE 40FTL

UNLESS OTHERWISE SPECIFIED
 TOLERANCES ON DIMENSIONS
 3 DECIMALS +/- 0.005
 2 DECIMALS +/- 0.015
 1 DECIMAL +/- 0.030
 ANGLES +/- 1/2 DEG
 MACHINED SURFACES 125 RMS MAX

SIGNATURES

MO-DA-YR

REV:

DRAWN: SCK

10/13/09

-

CHECKED:

-

SIZE:

MATERIAL: CST

WEIGHT:

-

REV: -

PART NUMBER:

3440FTL-03XX

C

SCALE: 0.300

SHEET 1 OF 1

OPW Engineered Systems
 A **DOVER** Resources Company
 Lebanon, Ohio 45036 USA

3D GENERATED DRAWING

A

B

C

D

1

1

2

2

3

3

4

4