

A

B

C

D

THIS DRAWING IS NOT TO BE SCALED. FOR ADDITIONAL INFORMATION. PLEASE CONTACT OUR ENGINEERING DEPT.

REVISIONS				DRAWN	APPROVED	DATE
LTR	ECN #	DESCRIPTION				
-	-	-	-	-	-	-

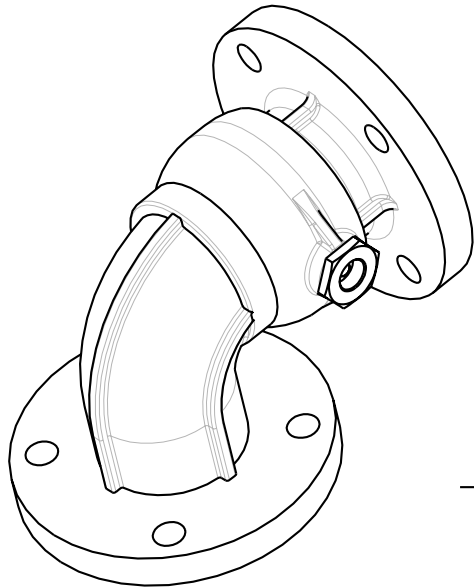

SCALE 0.350

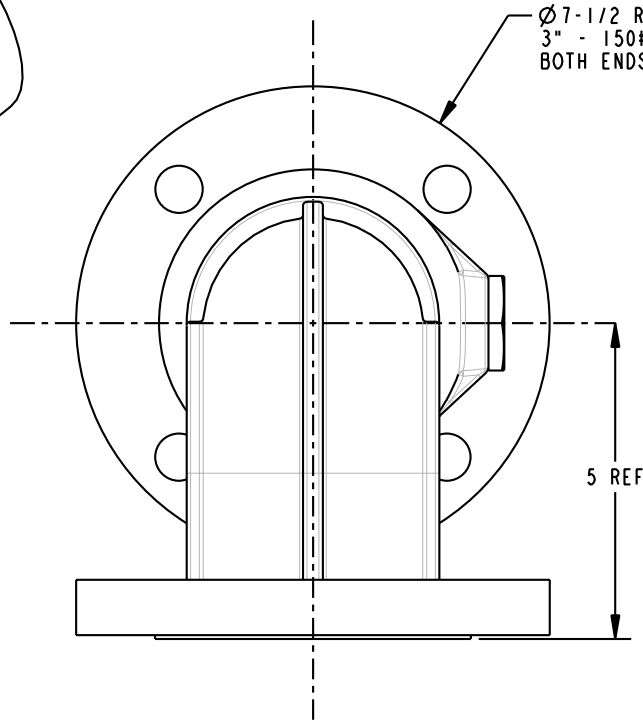

Ø7-1/2 REF  
3" - 150# FLANGE  
BOTH ENDS

5 REF

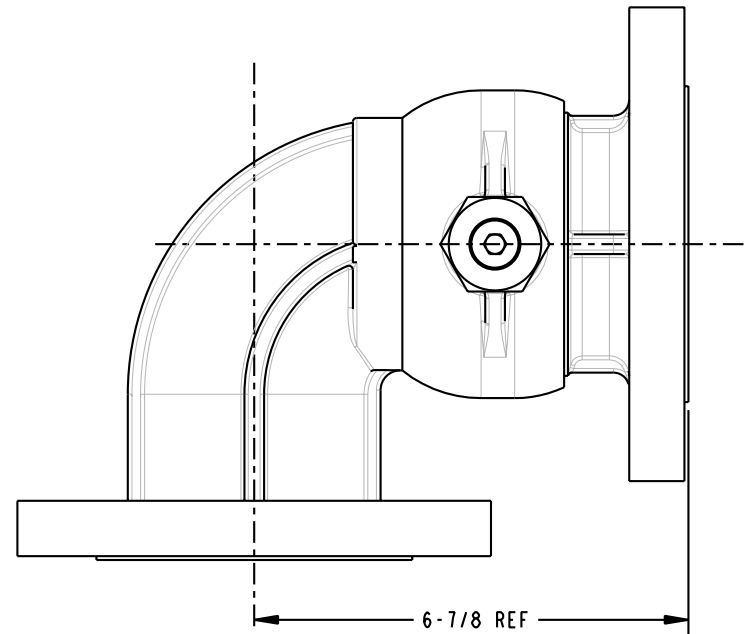

6-7/8 REF

**CONFIDENTIAL** THIS DOCUMENT CONTAINS INFORMATION WHICH IS PROPRIETARY TO OPW, AND SHOULD BE PROTECTED ACCORDINGLY.

DESCRIPTION: 3" SWIVEL,DI, STYLE 30F

UNLESS OTHERWISE SPECIFIED  
 TOLERANCES ON DIMENSIONS  
 3 DECIMALS +/- 0.005  
 2 DECIMALS +/- 0.015  
 1 DECIMAL +/- 0.030  
 ANGLES +/- 1/2 DEG  
 MACHINED SURFACES 125 RMS MAX

SIGNATURES		MO-DA-YR	REV:
DRAWN: SCK		01/31/07	-
CHECKED:			SIZE:
MATERIAL: DUCTILE IRON		WEIGHT:	C

PART NUMBER:	SCALE: 0.500	SHEET 1 OF 1
<b>3830F-03XX</b>		

**OPW** Engineered Systems  
 A **DOVER** Resources Company  
 Lebanon, Ohio 45036 USA

3D GENERATED DRAWING

A

B

C

D