

MATERIAL: DUCTILE IRON / STEEL / ALUMINUM
 VITON

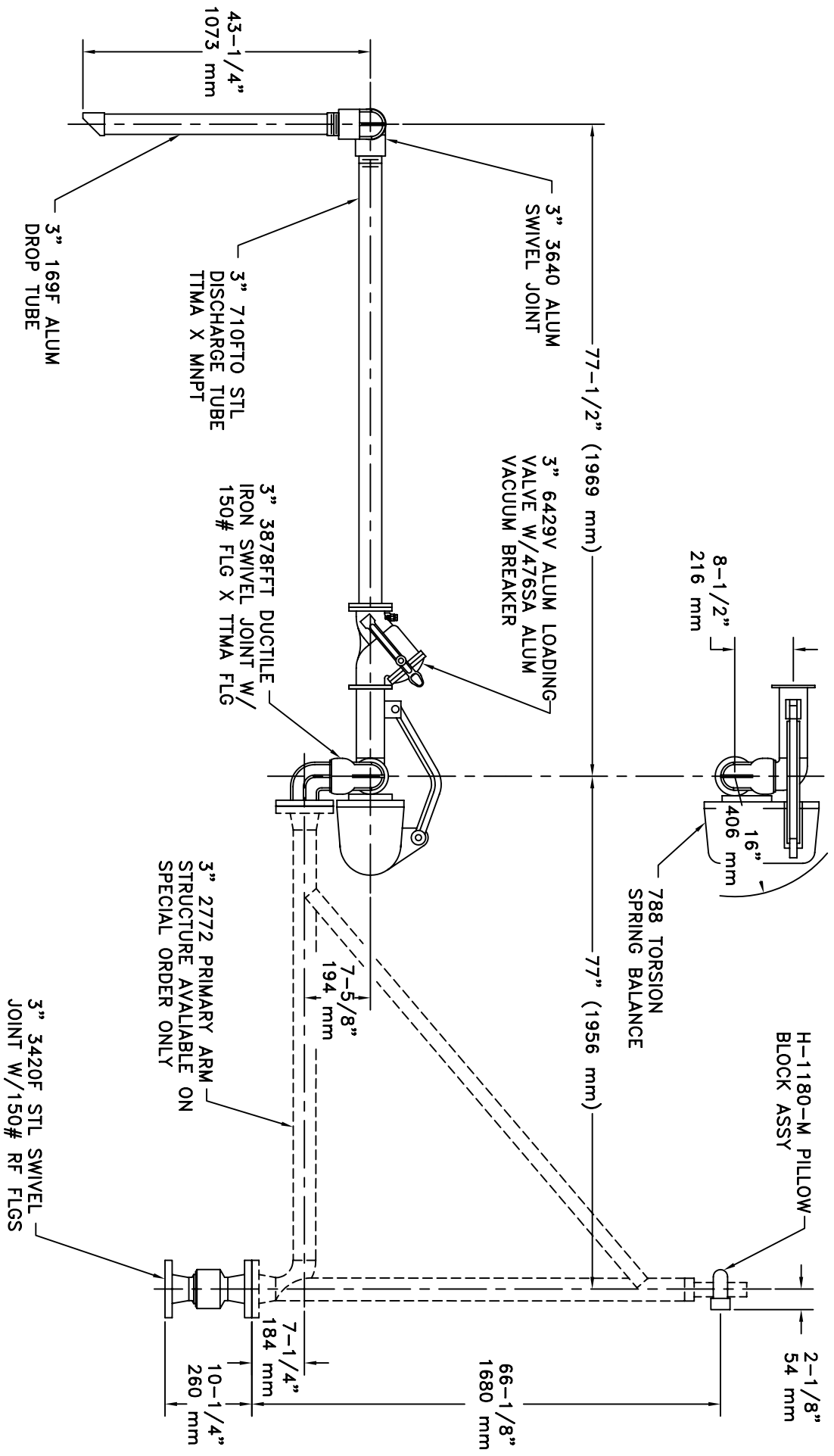

3" OPW B32F LIQUID LOADER



ARM IS DESIGNED FOR PRODUCT RETENTION TO POINT OF VALVE