

**A****B****C****D**

MATERIALS OF CONSTRUCTION	STEEL / ALUMINUM
SWIVEL JOINT SEALS	FDA NITRILE
PRODUCT	SOYBEAN OIL
WEIGHT	370 LBS
MOMENT LOAD AT SUPPORT	3900 IN-LBS
MOMENT LOAD AT INLET	17300 IN-LBS
FLANGE GASKETS	GARLOCK 3500
TEST PRESSURE	90 PSI
PRODUCT RETENTION	NO
RADIOGRAPHIC INSPECTION	NO
PMI TEST	NO
TIG PURGE	NO

THIS DRAWING IS NOT TO BE SCALED. FOR ADDITIONAL INFORMATION, PLEASE CONTACT OUR ENGINEERING DEPT.

REVISIONS			
LTR	ECN #	DESCRIPTION	DATE

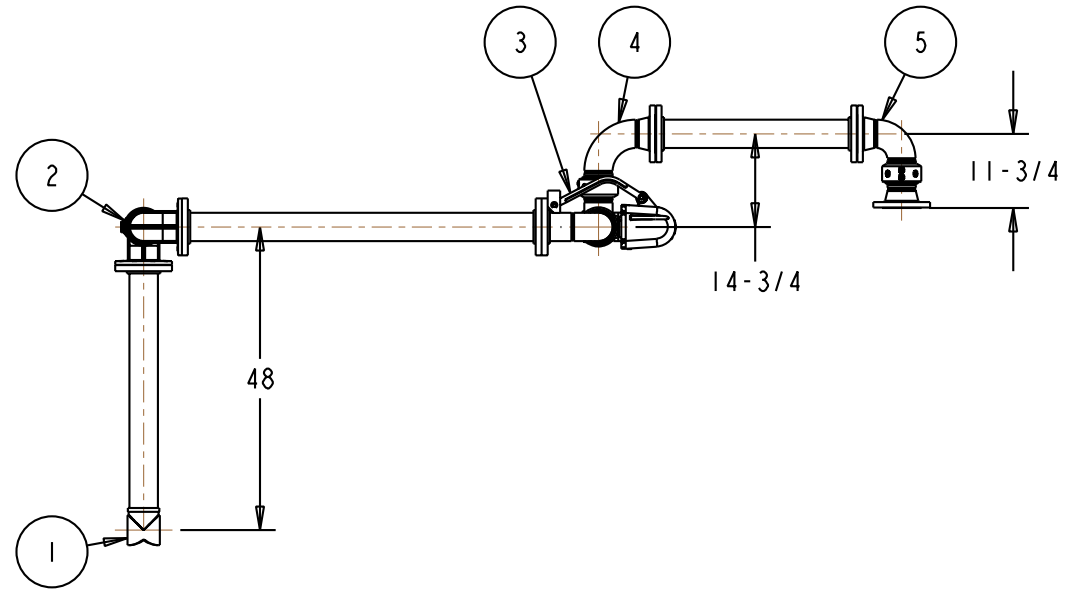
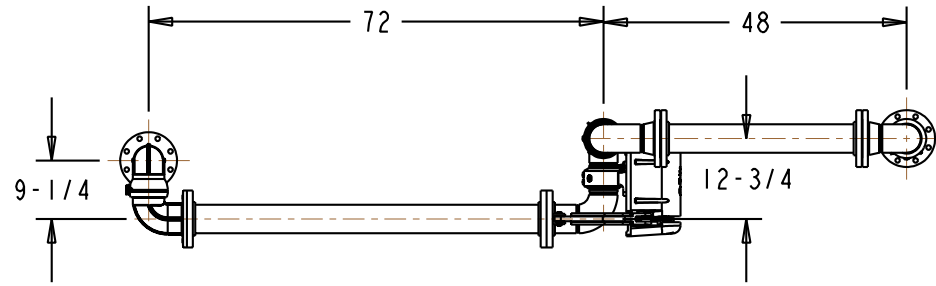

12	1	EA	HX99307	PIPE PKG, GT33F-J392, CST, SCH.40, 4"
11	1	EA	HX99307	PIPE PKG, GT33F-J392, AL, SCH.40, 4"
10	1	EA	HX99307	PIPE PKG, GT33F-392, AL, SCH.40, 4"
9	1	EA	LADOC-STD	LOADING ARM, NAME TAG AND HARDWARE
8	5	EA	FHK-150-04-CS-HT	FLG HARDWARE KIT, 150LB, CS, HI-TEMP, 4"
7	3	EA	H-10235-A	FLANGE, FFSO, 150#, AL, 4"
6	2	EA	H-08185-M	FLANGE, 150#, RFSO, CST, 4"
5	1	EA	3430F-0405	SWIVEL ASM, 3400, 150LB, FG NITRILE
4	1	EA	3478FSBLD-0405	4" SWIVEL, CST, FG NITRILE
3	1	EA	790ALH-0025	LEFT HAND EZ ADJUST 'A' SPRING BALANCE
2	1	EA	3640F-0405	4"SWIVEL, ALUM, FG NITRILE
1	1	EA	464-0200	4" ALUMINUM TEE DEFLECTOR
ITEM	QTY	UM	PART NUMBER	DESCRIPTION

**CONFIDENTIAL** THIS DOCUMENT CONTAINS INFORMATION WHICH IS PROPRIETARY TO OPW, AND SHOULD BE PROTECTED ACCORDINGLY.

DESCRIPTION: 4" LOADING ARM, CST/AL, FDA NITRILE, TEE DEFLECTOR, UF INLET, DFLH, 48X72X48

SIGNATURES		MO-DA-YR	REV:
DRAWN:	TES	08-DEC-10	-
CHECKED:	-	-	-
MATERIAL:	WEIGHT:	SIZE:	PART NUMBER:
Carbon Steel		C	GT33F-J392

SCALE: 0.050		SHEET 1 OF 4		3D GENERATED DRAWING	
--------------	--	--------------	--	----------------------	--

**A****B****C****D**