

MATERIALS OF CONSTRUCTION	316L STAINLESS STEEL
SWIVEL JOINT SEALS	PTFE
PRODUCT	SULFURIC ACID 93%
ESTIMATED WEIGHT	360 LBS
MOMENT LOAD AT SPRING	5,500 IN-LBS
MOMENT LOAD AT INLET	20,000 IN-LBS
FLANGE GASKETS	N/A
TEST PRESSURE	90 PSI
PRODUCT RETENTION	NO
WEIGHT BY OTHERS	N/A

2	1	EA	790A-0020	EZ ADJUST TORSION SPRING BALANCE
1	1	EA	8958FSW	3" SWIVEL, ENDURA DSF, SS, 3"
ITEM	QTY	UM	PART NUMBER	DESCRIPTION

THIS DRAWING IS NOT TO BE SCALED. FOR ADDITIONAL INFORMATION, PLEASE CONTACT OUR ENGINEERING DEPT.

REVISIONS					
LTR	ECN #	DESCRIPTION	DRAWN	APPROVED	DATE
-	-	-	-	-	-

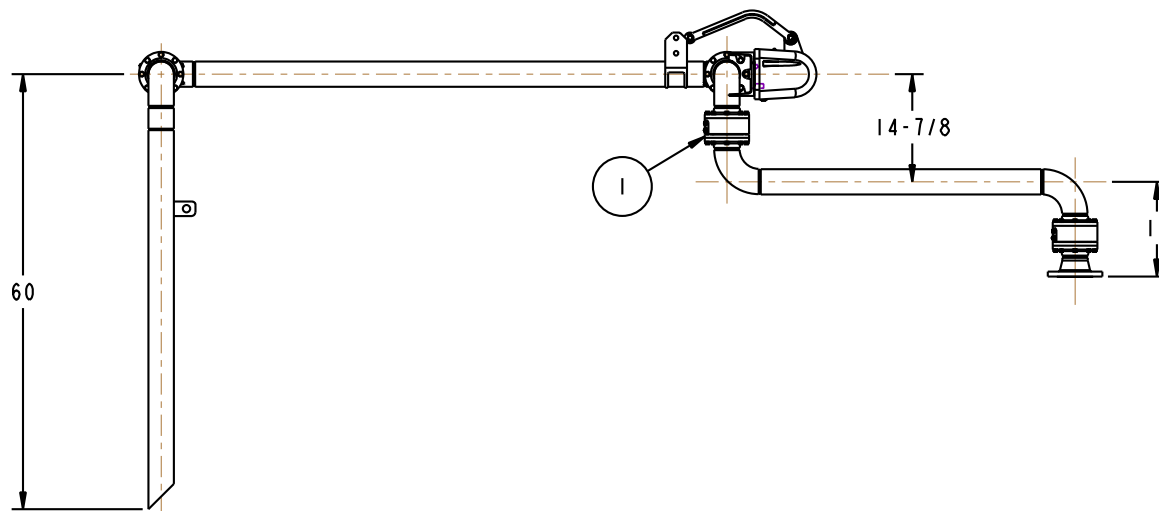
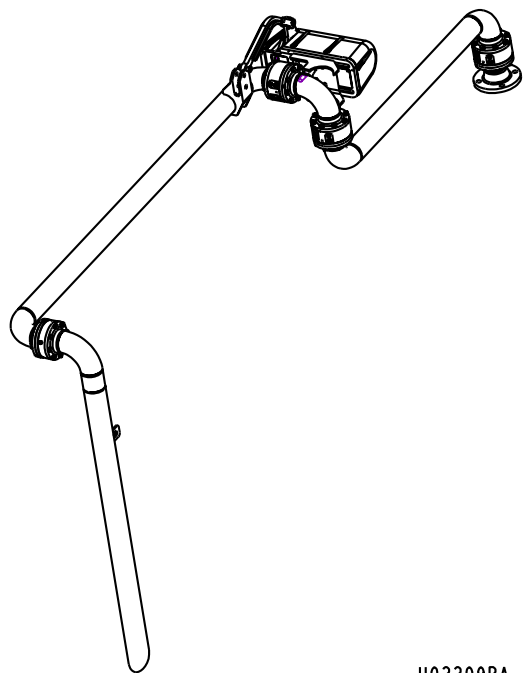
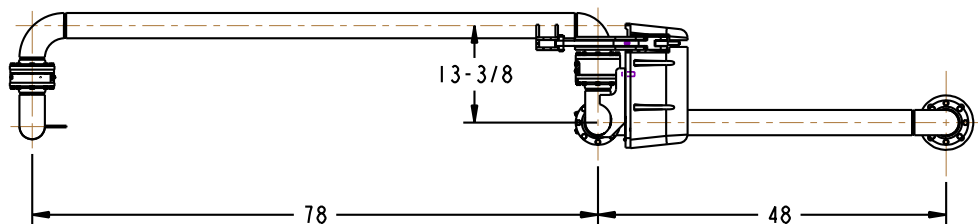

CONFIDENTIAL THIS DOCUMENT CONTAINS INFORMATION WHICH IS PROPRIETARY TO OPW, AND SHOULD BE PROTECTED ACCORDINGLY.

DESCRIPTION: 3" LOADING ARM, SK19330A

H02209PA 1 INSTRUCTION SHEET
H30446M 1 ALUM NAME PLATE
H30447M 2 SST TIE BANDS

SIGNATURES		MO-DA-YR
DRAWN:	JLP	3/03/09
CHECKED:	-	-
MATERIAL:	SST	WEIGHT:

REV:	-	PART NUMBER:	EGT32F-H230
SIZE:	D	SCALE:	0.080
SHEET 1 OF 3		3D GENERATED DRAWING	

OPW **Engineered Systems**
A **ROBERT** Resources Company
Lebanon, Ohio 45036 USA