

MATERIALS OF CONSTRUCTION	316L STAINLESS STEEL
SWIVEL JOINT SEALS	PTFE
PRODUCT	MEMBRANE CAUSTIC
ESTIMATED WEIGHT	360 LBS
MOMENT LOAD AT SPRING	12,100 IN-LBS
FLANGE GASKETS	GARLOCK 3510
TEST PRESSURE	90 PSI
PRODUCT RETENTION	NO
WEIGHT BY OTHERS	TRACE & INSULATION @ 2.5 LBS/FT

8	1	EA	788LLH-0045	LOCKDOWN UNIT
7	1	EA	790CLH-0045	LEFT HAND EZ ADJUST 'C' SPRING BALANCE
6	1	EA	3958FSBD-0403	4" SWIVEL, SST
5	1	EA	3940FO-0403	4" SWIVEL, SST
4	1	EA	634B-SS40-H770	4" SST KAMLOK DUST CAP
3	1	EA	633A-SS40	4" SST AUTOLOK ADAPTOR
2	1	EA	N/A	4" CST PIPE SPOOL
1	1	EA	N/A	4" CST DROP PIPE SPOOL W/HANDLES
ITEM	QTY	UM	PART NUMBER	DESCRIPTION

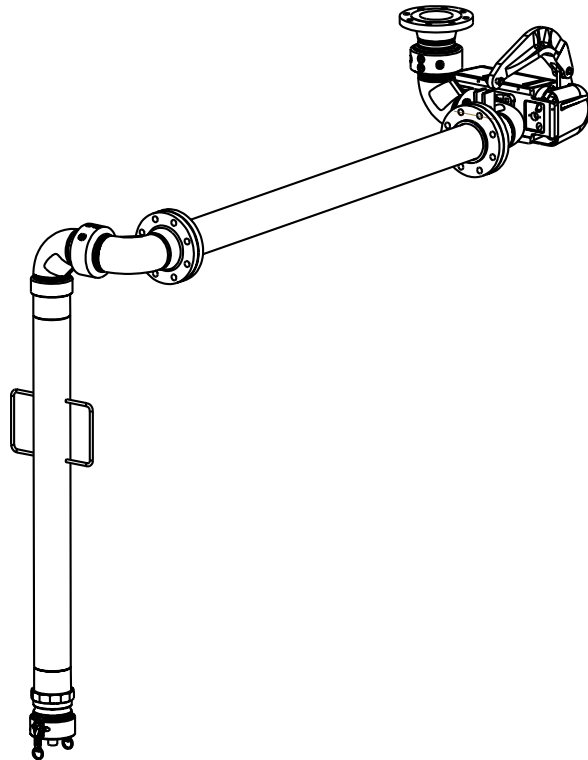

THIS DRAWING IS NOT TO BE SCALED. FOR ADDITIONAL INFORMATION, PLEASE CONTACT OUR ENGINEERING DEPT.

REVISIONS					
LTR	ECN #	DESCRIPTION	DRAWN	APPROVED	DATE
-	-	-	-	-	-

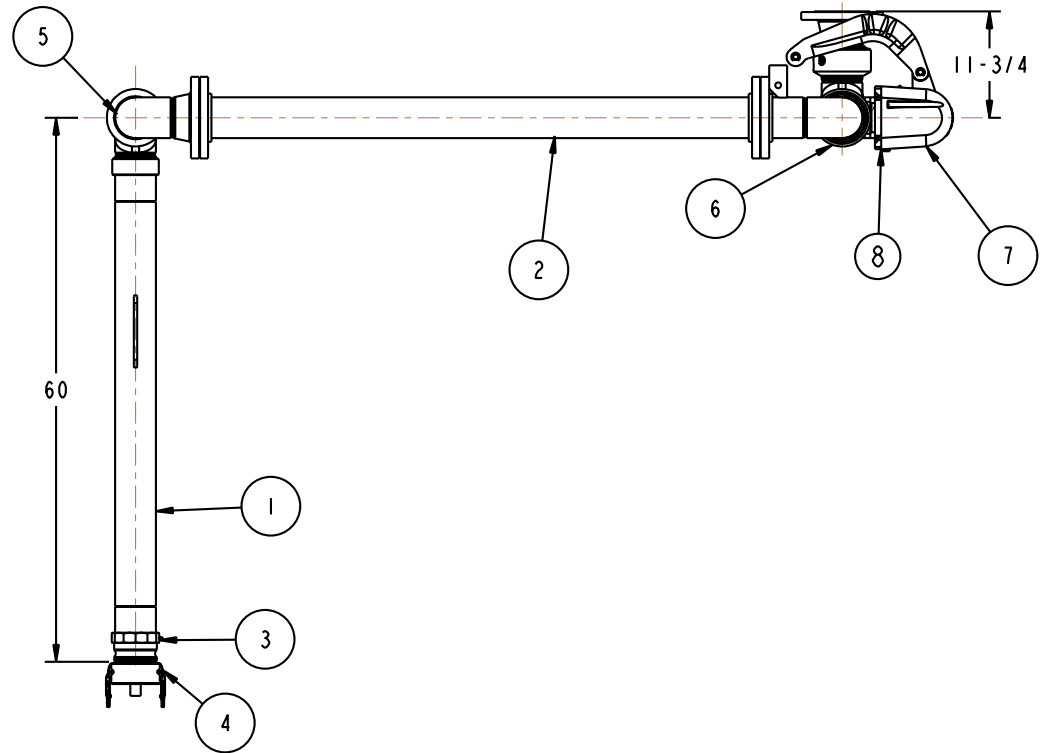
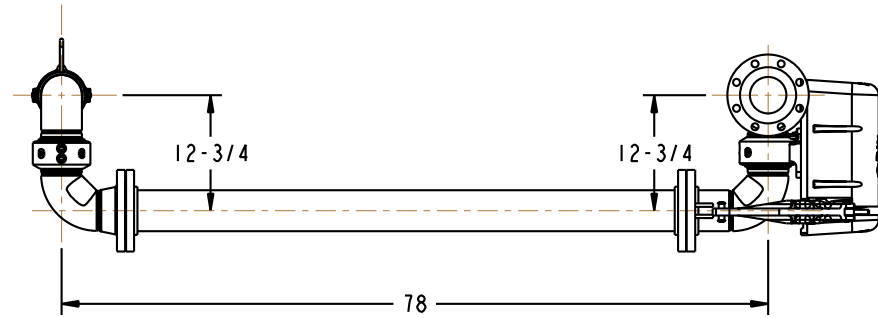

CONFIDENTIAL THIS DOCUMENT CONTAINS INFORMATION WHICH IS PROPRIETARY TO OPW, AND SHOULD BE PROTECTED ACCORDINGLY.

DESCRIPTION: 4" TOP LOADING ARM, DFLH

SIGNATURES	MO-DA-YR
DRAWN: JLP	1/21/10
CHECKED:	-
MATERIAL:	WEIGHT:

REV: -  
SIZE: D

PART NUMBER:  
**J33F-H768**  
SCALE: 0.100 SHEET 1 OF 3

**OPW Engineered Systems**  
A BOSTED Resources Company  
Lebanon, Ohio 45036 USA  
3D GENERATED DRAWING