

MATERIALS OF CONSTRUCTION	316L STAINLESS STEEL
SWIVEL JOINT SEALS	PTFE ENCAPSULATED FLUOROCARBON
PRODUCT	50% CAUSTIC SODA
ESTIMATED WEIGHT	400 LBS
MOMENT LOAD AT SPRING	4325 IN-LBS
MOMENT LOAD AT INLET	25,050 IN-LBS
FLANGE GASKETS	GARLOCK 3510
FLANGE HARDWARE PER ANSI B16.5	A193 GR B7 FLUOROPOLYMER COATED (LIGHT BLUE) STUD BOLTS A194 GR 2H HVY HEX FLUOROPOLYMER COATED (LIGHT BLUE) NUT
TEST PRESSURE	225 PSI
PRODUCT RETENTION	NO
WEIGHT BY OTHERS	NO
RADIOGRAPHIC INSPECTION	5% FLOW PASSAGE WELDS
MATERIAL TEST REPORTS	REQUIRED
TAG LOADING ARMS	PO# SPTNK-150673 / PROJECT CU-220 RAIL ARMS ALA-810 B

6	I	EA	H-01180-M	PILLOW BLOCK BEARING
5	I	EA	788LLH-0045	LOCKDOWN UNIT, LEFT HAND
4	I	EA	790ALH-0025	LEFT HAND EZ ADJUST 'A' SPRING BALANCE
3	I	EA	3958FSBWD	3" WELDED SWIVEL ASSY, SST
2	I	EA	3920F	3" SWIVEL ASSY W/POSITION SWITCH & LOCKING DEVICE
1	I	EA	N/A	3" BOOM ASSY W/SST WETTED PARTS
ITEM	QTY	UM	PART NUMBER	DESCRIPTION

THIS DRAWING IS NOT TO BE SCALED. FOR ADDITIONAL INFORMATION, PLEASE CONTACT OUR ENGINEERING DEPT.

REVISIONS					
LTR	ECN #	DESCRIPTION	DRAWN	APPROVED	DATE
-	-	-	-	-	-

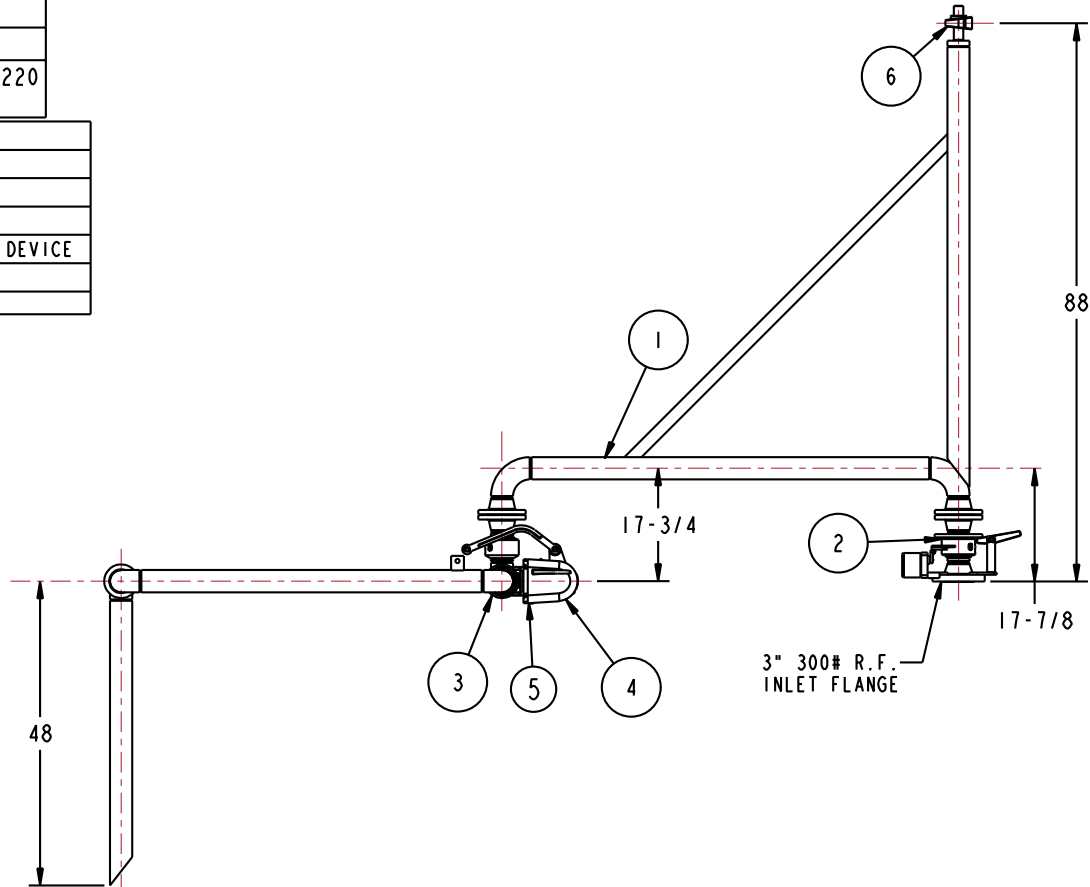
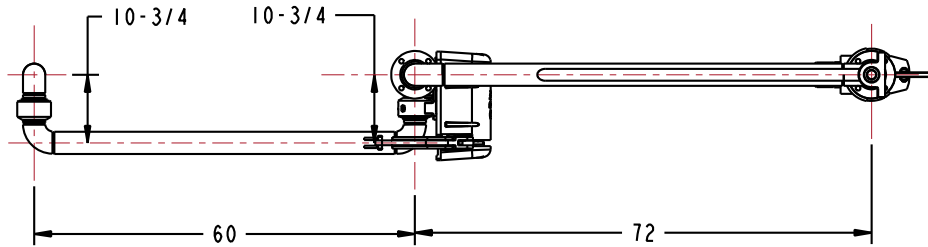

CONFIDENTIAL THIS DOCUMENT CONTAINS INFORMATION WHICH IS PROPRIETARY TO OPW, AND SHOULD BE PROTECTED ACCORDINGLY.

SIGNATURES		MO-DA-YR	REV:	DESCRIPTION: 3" TOP LOADING ARM, DFLH	
DRAWN: BJB		1/21/10	-	PART NUMBER: B33F-H748	
CHECKED:			SIZE: D	SCALE: 0.070 SHEET 1 OF 7	
MATERIAL:	WEIGHT:			3D GENERATED DRAWING	

OPW Engineered Systems
A **ROBERT** Resources Company
Lebanon, Ohio 45036 USA

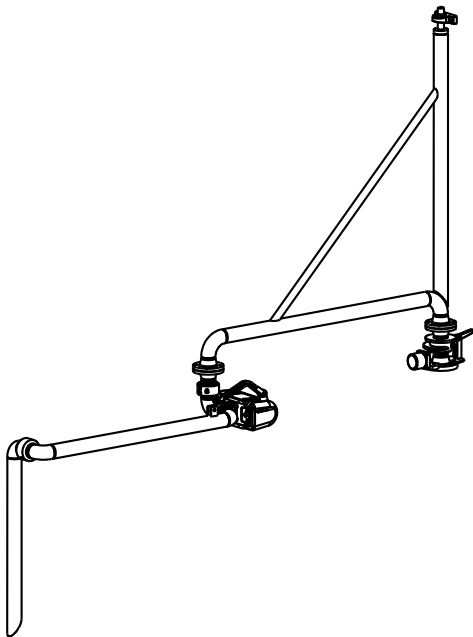

THIS DRAWING IS NOT TO BE SCALED. FOR ADDITIONAL INFORMATION, PLEASE CONTACT OUR ENGINEERING DEPT.

6	1	EA	H31954	TAIL-EF, 3900, 300# FLG, 3"
5	1	EA	HX98539	SWITCH, ROTARY LEVER,
4	1	EA	HX98527	SWITCH BRACKET, SST
3	1	EA	HX98538	MICRO SWITCH
2	1	EA	N/A	LOCKING DEVICE
1	1	EA	N/A	BODY, CF, SST, 3"
ITEM	QTY	UM	PART NUMBER	DESCRIPTION

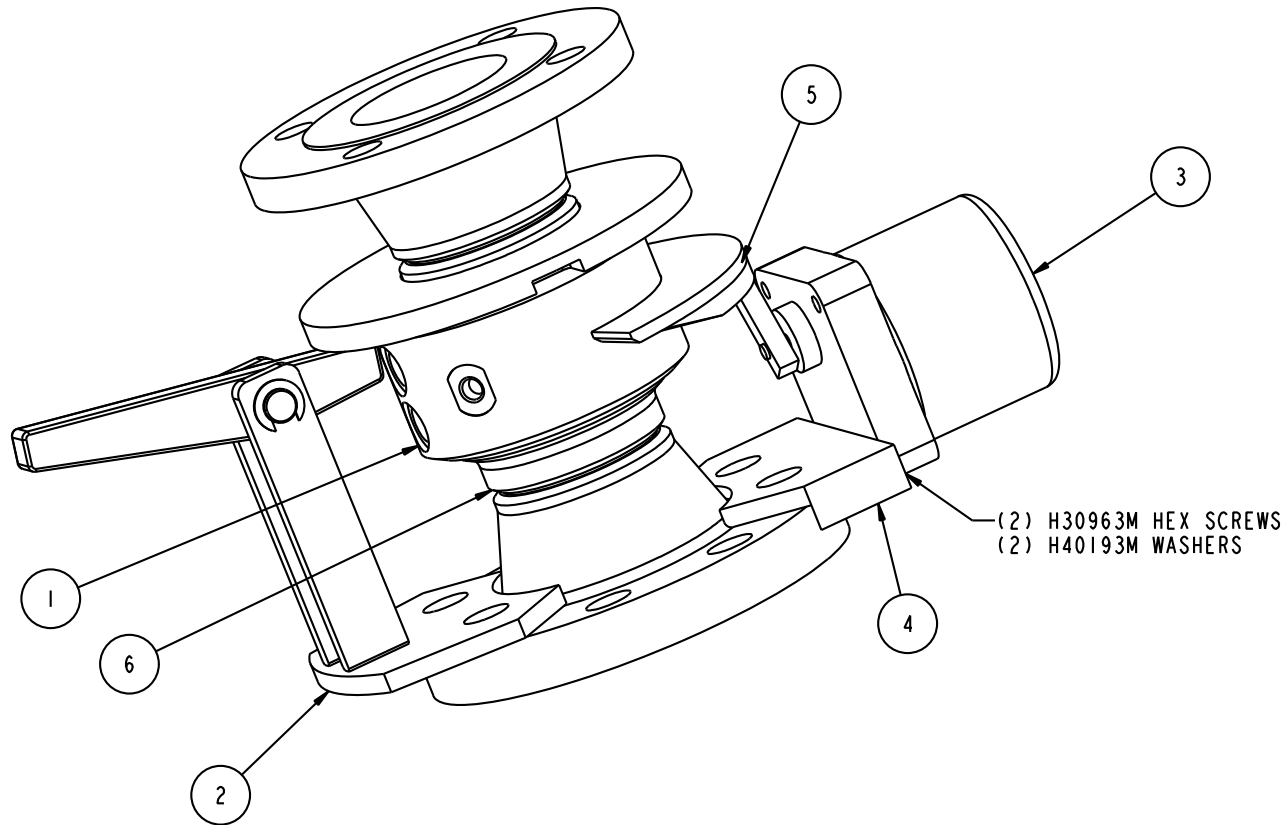

CONFIDENTIAL THIS DOCUMENT CONTAINS INFORMATION WHICH IS PROPRIETARY TO OPW, AND SHOULD BE PROTECTED ACCORDINGLY.			DESCRIPTION: 3" TOP LOADING ARM, DFLH	
SIGNATURES		MO-DA-YR	REV:	PART NUMBER:
DRAWN: BJB		1/21/10	-	B33F-H748
CHECKED:		-	SIZE:	D
MATERIAL:		WEIGHT:	SCALE: 0.070 SHEET 2 OF 7	
			Engineered Systems <small>A BOSTED Resources Company</small> Lebanon, Ohio 45036 USA 3D GENERATED DRAWING	