

A

B

C

D

THIS DRAWING IS NOT TO BE SCALED. FOR ADDITIONAL INFORMATION. PLEASE CONTACT OUR ENGINEERING DEPT.

REVISIONS

LTR	ECN #	DESCRIPTION	DRAWN	APPROVED	DATE
-	-	-	-	-	-

MATERIALS OF CONSTRUCTION	CARBON STEEL
SWIVEL JOINT SEALS	FLUOROCARBON
PRODUCT	ASPHALT
WEIGHT	290 LBS
MOMENT LOAD AT SUPPORT	10800 IN-LBS
MOMENT LOAD AT INLET	10800 IN-LBS
FLANGE GASKETS	GARLOCK
TEST PRESSURE	90 PSI
PRODUCT RETENTION	NO
RADIOGRAPHIC INSPECTION	NO
PMI TEST	NO
TIG PURGE	NO
WEIGHT BY OTHERS	YES, NOT TO EXCEED 2.5LBS/FT

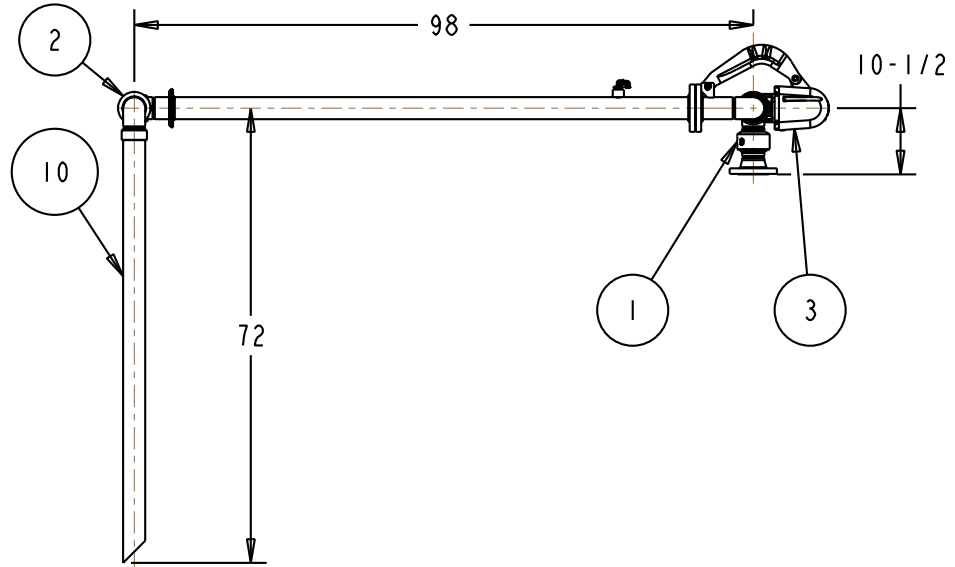
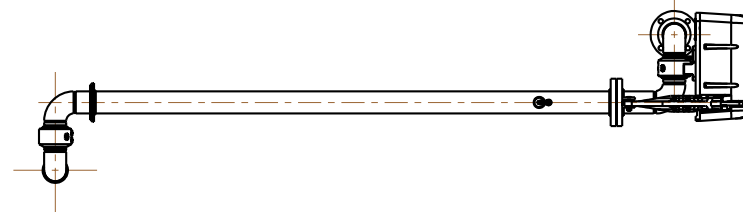

ITEM	QTY	UM	PART NUMBER	DESCRIPTION
11	1	EA	489-0060	VACUUM BREAKER, SST, 1" FNPT
10	2	EA	HX98945	PIPE PKG, J32F-J206, CST, 3
9	1	EA	LADOC-STD	LOADING ARM, NAME TAG AND HARDWARE
8	1	EA	C03286M	FLANGE, CST, TTMA, FORMED, 3"
7	1	EA	H08183M	FLANGE, 150#, RFSO, CST, 3"
6	1	EA	FHK-TTMA-03-CS	FLANGE HARDWARE KIT, TTMA, CS, 3"
5	1	EA	FHK-150-03-CS	FLANGE HARDWARE KIT, 150LB, CS, 3"
4	1	EA	P-13016-CST	COUPLING, HALF, 3000#, CST, 1"
3	1	EA	790CLH-0045	LEFT HAND EZ ADJUST 'C' SPRING BALANCE
2	1	EA	3440FTO-0302-J206	SWIVEL ASM, TTMA X THRD, ALL GFLT, CST, 3"
1	1	EA	3456FSB-0302-J206	3" 3400 SWIVEL, SPRING BALANCE, ALL GFLT

CONFIDENTIAL THIS DOCUMENT CONTAINS INFORMATION WHICH IS PROPRIETARY TO OPW, AND SHOULD BE PROTECTED ACCORDINGLY.

DESCRIPTION: 4" LOADING ARM, CST, FLUOROCARBON, 98 X 72

SIGNATURES		MO-DA-YR	REV:	PART NUMBER:	
DRAWN:	TES	09-SEP-10	-	J32F-J206	
CHECKED:	-	-	SIZE:	SCALE: 0.050 SHEET 1 OF 4	
MATERIAL:	WEIGHT:	C		3D GENERATED DRAWING	
Carbon Steel					

A

B

C

D

OPW Engineered Systems  
A DOVER Resources Company  
Lebanon, Ohio 45036 USA