

MATERIALS OF CONSTRUCTION	CARBON STEEL
SWIVEL JOINT SEALS	FLUOROCARBON GFLT
PRODUCT	ASPHALT EMULSION
ESTIMATED WEIGHT	250 LBS
MOMENT LOAD AT SPRING	7400 IN-LBS
FLANGE GASKETS	KLINGER SIL C5400
TEST PRESSURE	90 PSI
PRODUCT RETENTION	NO
WEIGHT BY OTHERS	NO

6	I	EA	788L-0040	LOCKDOWN UNIT
5	I	EA	790B-0030	RIGHT HAND EZ ADJUST 'B' SPRING BALANCE
4	I	EA	3458FSB-0302	3" SWIVEL, CST
3	I	EA	3440FT-0302	3" SWIVEL, CST
2	I	EA	N/A	3" CST PIPE SPOOL
1	I		N/A	3" CST DROP TUBE
ITEM	QTY	UM	PART NUMBER	DESCRIPTION

THIS DRAWING IS NOT TO BE SCALED. FOR ADDITIONAL INFORMATION, PLEASE CONTACT OUR ENGINEERING DEPT.

REVISIONS					
LTR	ECN #	DESCRIPTION	DRAWN	APPROVED	DATE
-	-	-	-	-	-

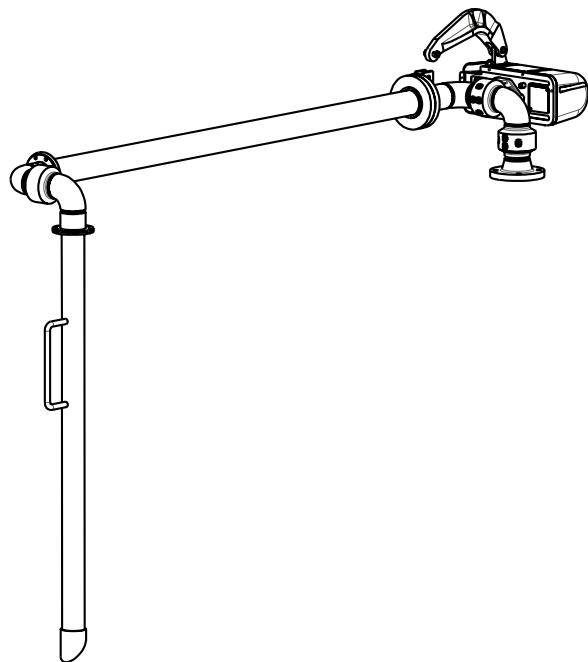
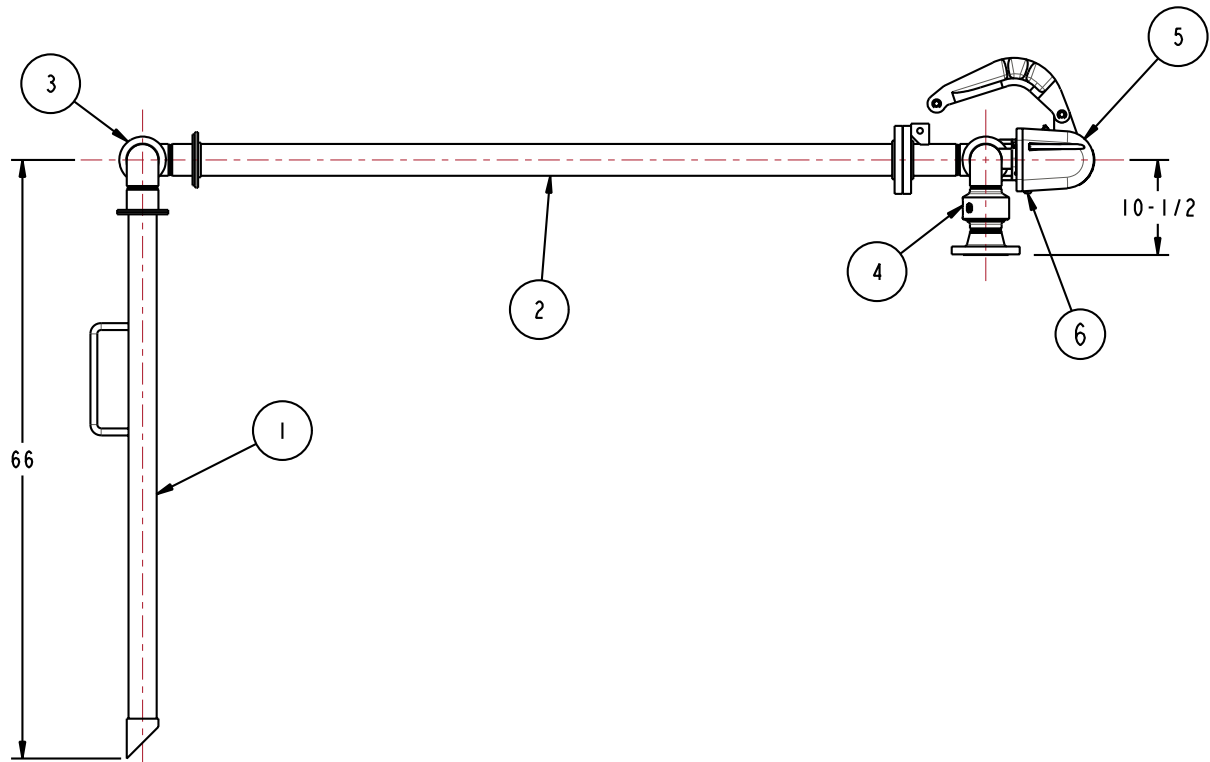
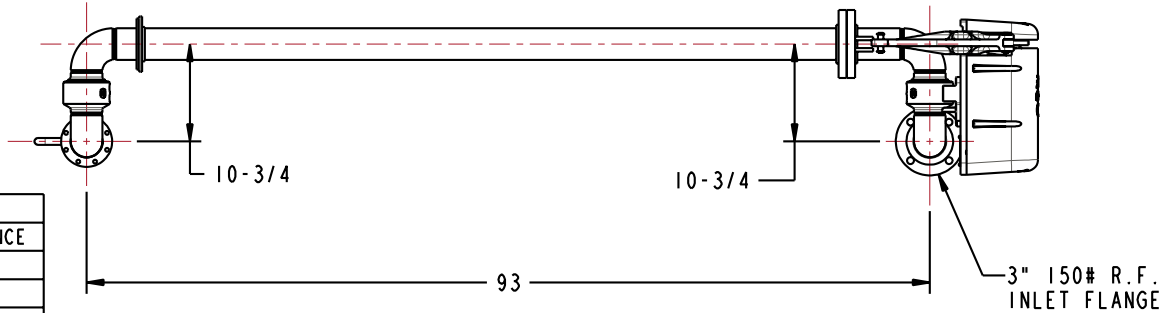

CONFIDENTIAL THIS DOCUMENT CONTAINS INFORMATION WHICH IS PROPRIETARY TO OPW, AND SHOULD BE PROTECTED ACCORDINGLY.

DESCRIPTION: 3" TOP LOADING ARM, UFRH

SIGNATURES		MO-DA-YR
DRAWN: BJB		1/15/10
CHECKED:		
MATERIAL: CST	WEIGHT:	

REV: -	PART NUMBER:
SIZE: D	J32F-H762
SCALE: 0.100	SHEET 1 OF 2

OPW Engineered Systems
 A **ROBERT** Resources Company
 Lebanon, Ohio 45036 USA
 3D GENERATED DRAWING