

MATERIALS OF CONSTRUCTION	CARBON STEEL
SWIVEL JOINT SEALS	FLUOROCARBON GFLT
PRODUCT	ASPHALT EMULSION
ESTIMATED WEIGHT	300 LBS
MOMENT LOAD AT SPRING	9750 IN-LBS
FLANGE GASKETS	KLINGER SIL C5400
TEST PRESSURE	90 PSI
PRODUCT RETENTION	NO
WEIGHT BY OTHERS	NO

6	1	EA	788LLH-0045	LOCKDOWN UNIT
5	1	EA	790CLH-0045	LEFT HAND EZ ADJUST 'C' SPRING BALANCE
4	1	EA	3456FSB-0402	4" SWIVEL, CST
3	1	EA	3440FT-0402	4" SWIVEL, CST
2	1	EA	N/A	4" CST PIPE SPOOL
1	1	EA	N/A	4" CST DROP TUBE ASSY W/HANDLE
ITEM	QTY	UM	PART NUMBER	DESCRIPTION

THIS DRAWING IS NOT TO BE SCALED. FOR ADDITIONAL INFORMATION, PLEASE CONTACT OUR ENGINEERING DEPT.

REVISIONS					
LTR	ECN #	DESCRIPTION	DRAWN	APPROVED	DATE
-	-	-	-	-	-

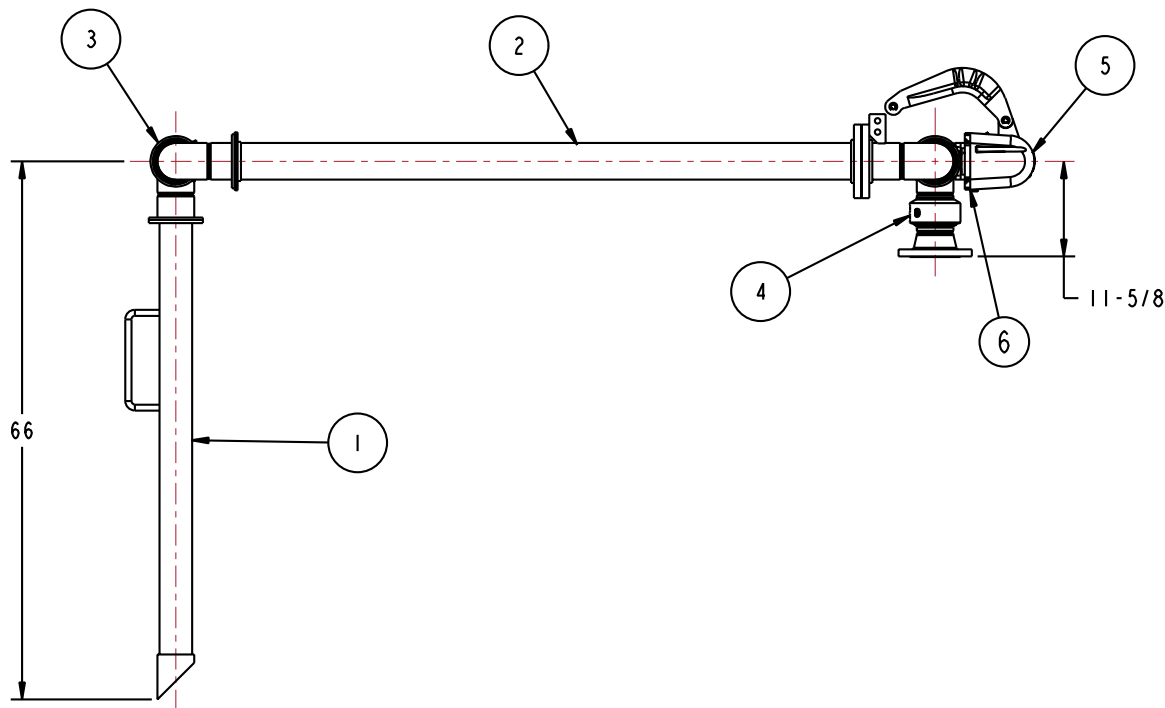
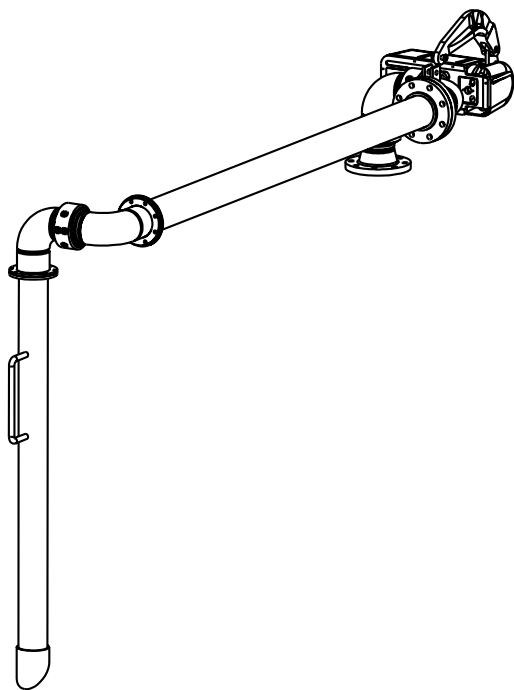
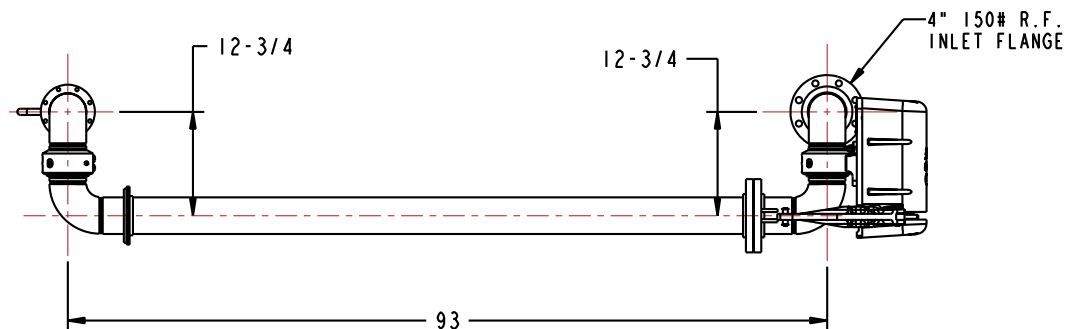

CONFIDENTIAL THIS DOCUMENT CONTAINS INFORMATION WHICH IS PROPRIETARY TO OPW, AND SHOULD BE PROTECTED ACCORDINGLY.

DESCRIPTION: 4" TOP LOADING ARM, UFLH

SIGNATURES	MO-DA-YR
DRAWN: BJB	1/14/10
CHECKED:	-
MATERIAL:	WEIGHT:

REV: -
SIZE: D

PART NUMBER:
J32F-H761
SCALE: 0.090

OPW **Engineered Systems**
A **ROBERT** Resources Company
Lebanon, Ohio 45036 USA
3D GENERATED DRAWING

SHEET 1 OF 2