

MATERIALS OF CONSTRUCTION	CARBON STEEL
SWIVEL JOINT SEALS	FLUOROCARBON
PRODUCT	ASPHALT EMULSION
ESTIMATED WEIGHT	300 LBS
MOMENT LOAD AT SPRING	9700 IN-LBS
FLANGE GASKETS	KLINGER SIL C5400
TEST PRESSURE	90 PSI
PRODUCT RETENTION	NO
WEIGHT BY OTHERS	NO

5	I	EA	790CLH-0045	LEFT HAND EZ ADJUST 'C' SPRING BALANCE
4	I	EA	3458FSBD-0402	4" SWIVEL, CST
3	I	EA	3440FTO-0402	4" SWIVEL, CST
2	I	EA	N/A	4" CST PIPE SPOOL
1	I	EA	N/A	4" CST DROP TUBE ASSY
ITEM	QTY	UM	PART NUMBER	DESCRIPTION

THIS DRAWING IS NOT TO BE SCALED. FOR ADDITIONAL INFORMATION, PLEASE CONTACT OUR ENGINEERING DEPT.

REVISIONS					
LTR	ECN #	DESCRIPTION	DRAWN	APPROVED	DATE
-	-	-	-	-	-

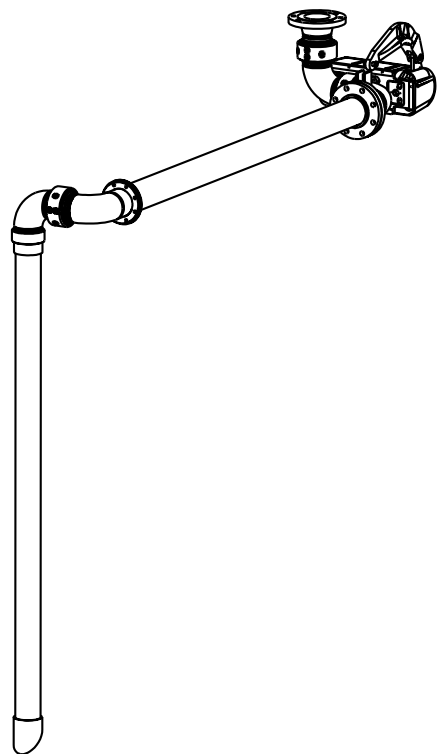
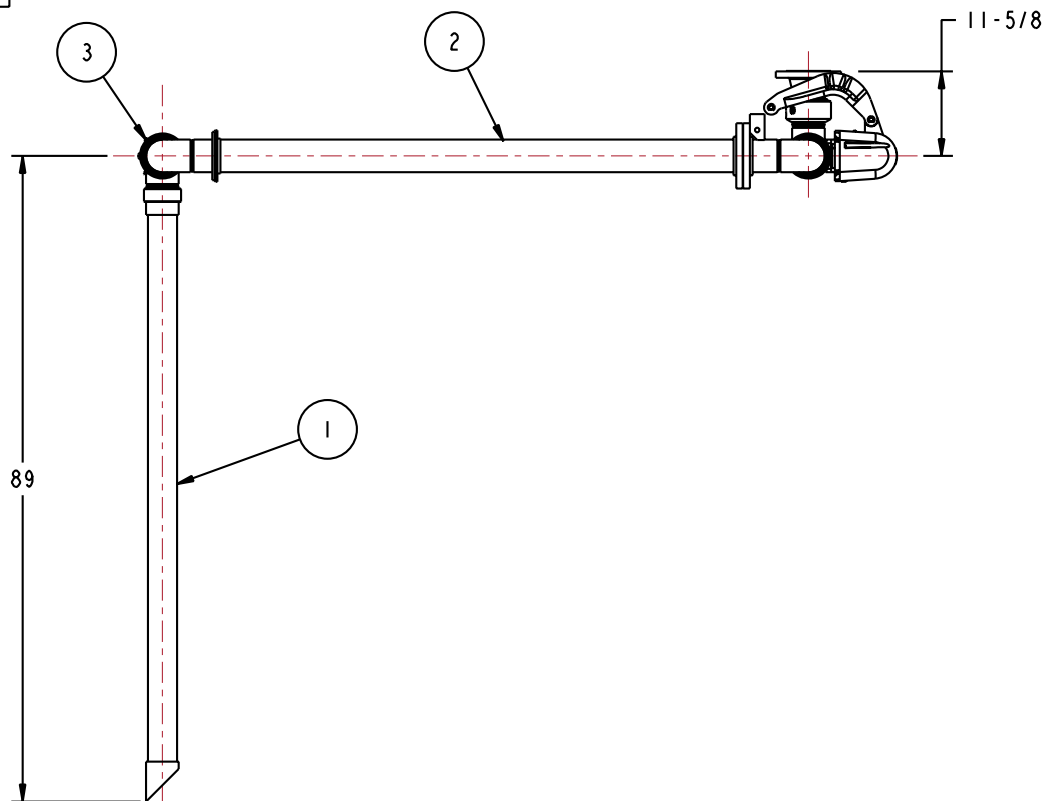
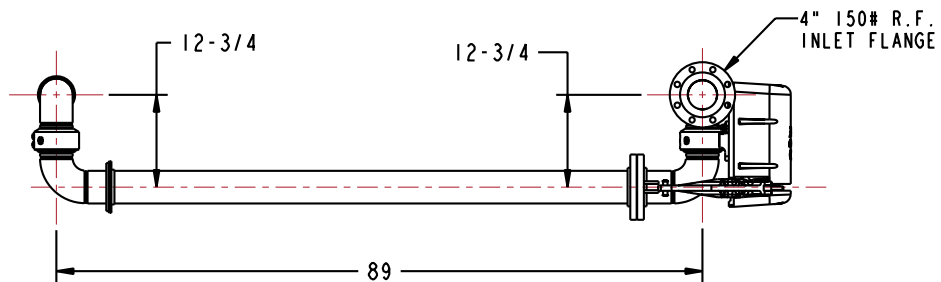

CONFIDENTIAL THIS DOCUMENT CONTAINS INFORMATION WHICH IS PROPRIETARY TO OPW, AND SHOULD BE PROTECTED ACCORDINGLY.

DESCRIPTION: 4" TOP LOADING ARM, DFLH

SIGNATURES		MO-DA-YR
DRAWN: BJB		8/18/09
CHECKED:		
MATERIAL:	WEIGHT:	

REV: -	PART NUMBER:
SIZE: D	J33F-H510
SCALE: 0.080 SHEET 1 OF 2	

OPW Engineered Systems
 A **ROBERT** Resources Company
 Lebanon, Ohio 45036 USA
 3D GENERATED DRAWING