

MATERIALS OF CONSTRUCTION	CARBON STEEL
SWIVEL JOINT SEALS	MAIN: FLUOROCARBON GFLT DUST: FLUOROCARBON GFLT
PRODUCT	ASPHALT EMULSION
ESTIMATED WEIGHT	325 LBS
MOMENT LOAD AT SPRING	10,150 IN-LBS
FLANGE GASKETS	GARLOCK GYLON 3500
TEST PRESSURE	90 PSI
PRODUCT RETENTION	NO
WEIGHT BY OTHERS	NO

ITEM	QTY	UM	PART NUMBER	DESCRIPTION
5	1	EA	790C-0050	RIGHT HAND EZ ADJUST 'C' SPRING BALANCE
4	1	EA	3456FSBD	4" SWIVEL, CST
3	1	EA	3440FTO	4" SWIVEL, CST
2	1	EA	N/A	4" CST PIPE SPOOL
1	1	EA	N/A	4" CST DROP TUBE ASSY

THIS DRAWING IS NOT TO BE SCALED. FOR ADDITIONAL INFORMATION, PLEASE CONTACT OUR ENGINEERING DEPT.

REVISIONS					
LTR	ECN #	DESCRIPTION	DRAWN	APPROVED	DATE
-	-	-	-	-	-

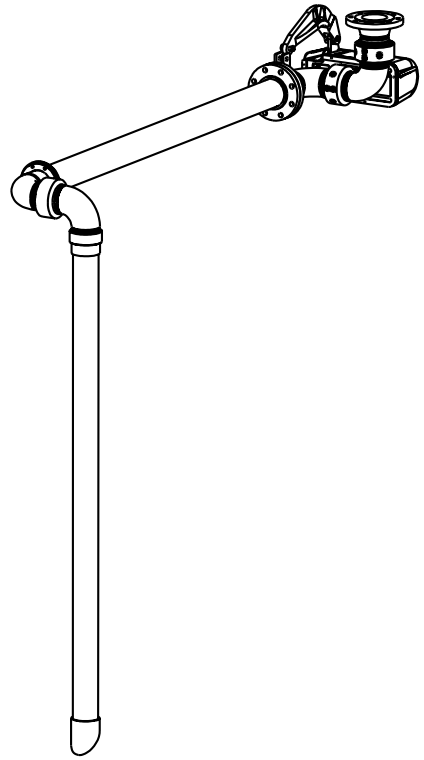
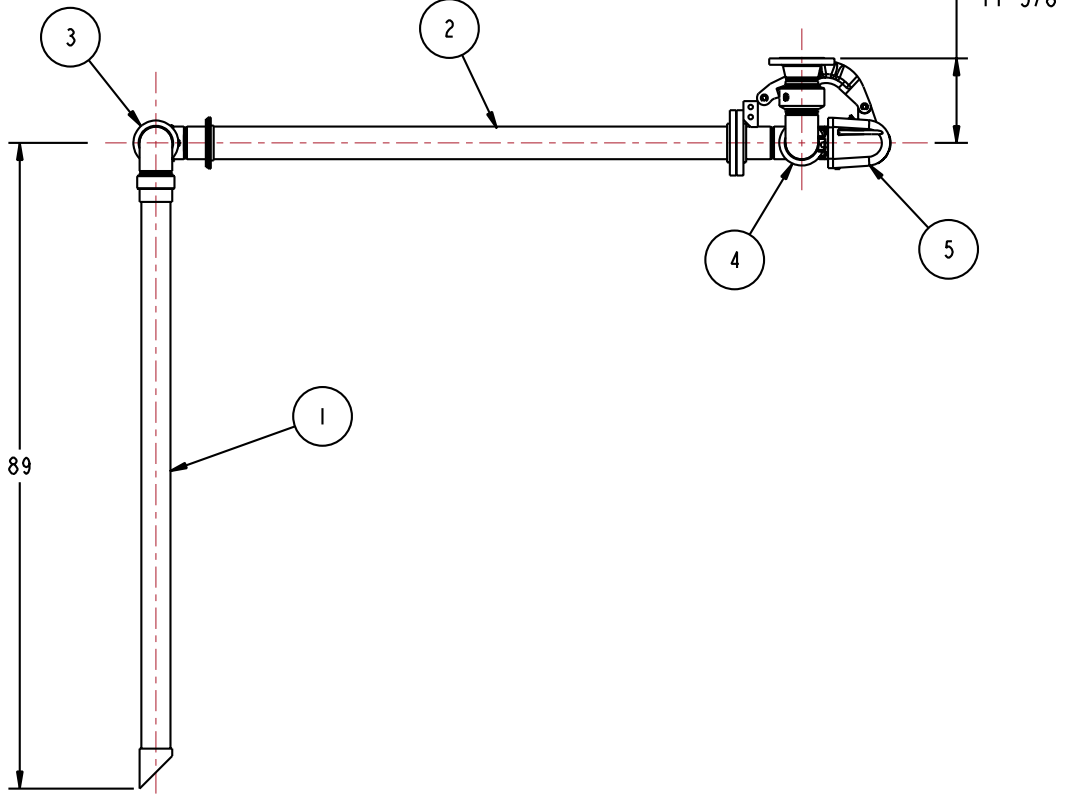
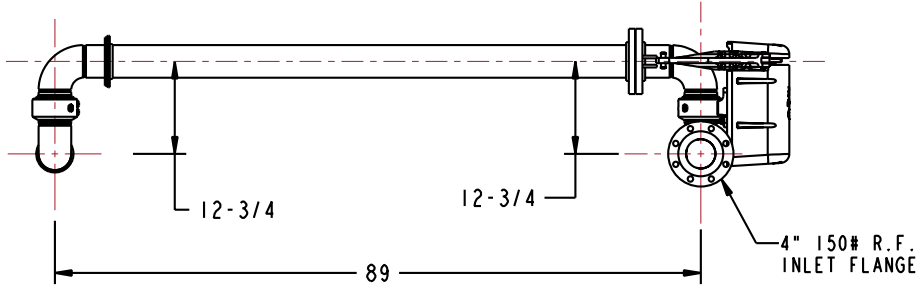

CONFIDENTIAL THIS DOCUMENT CONTAINS INFORMATION WHICH IS PROPRIETARY TO OPW, AND SHOULD BE PROTECTED ACCORDINGLY.

SIGNATURES		MO-DA-YR	REV:	DESCRIPTION: 4" TOP LOADING ARM, DFRH	
DRAWN:	BJB	3/9/10	-	PART NUMBER: <b>J33F-H869</b>	
CHECKED:	-	-	SIZE: D	SCALE: 0.080 SHEET 1 OF 2	
MATERIAL:	WEIGHT:	-	3D GENERATED DRAWING		

