

MATERIALS OF CONSTRUCTION	CARBON STEEL
SWIVEL JOINT SEALS	MAIN: FLUOROCARBON GFLT ENVIRONMENTAL: FLUOROCARBON GFLT
PRODUCT	ASPHALT & ASPHALT EMULSIONS
ESTIMATED WEIGHT	300 LBS
MOMENT LOAD AT SPRING	9800 IN-LBS
FLANGE GASKETS	GARLOCK GYLON 3500
TEST PRESSURE	90 PSI
PRODUCT RETENTION	NO
WEIGHT BY OTHERS	TRACE & INSULATION @ 2.5 LBS/FT

6	1	EA	788LLH-0045	LOCKDOWN UNIT
5	1	EA	790CLH-0045	LEFT HAND EZ ADJUST 'C' SPRING BALANCE
4	1	EA	3458FSBD	4" SWIVEL, CST
3	1	EA	3444FT	4" SWIVEL, CST
2	1	EA	N/A	4" CST PIPE SPOOL W/HANDLE & BUCKET HOOK
1	1	EA	N/A	4" CST PIPE SPOOL
ITEM	QTY	UM	PART NUMBER	DESCRIPTION

THIS DRAWING IS NOT TO BE SCALED. FOR ADDITIONAL INFORMATION, PLEASE CONTACT OUR ENGINEERING DEPT.

REVISIONS					
LTR	ECN #	DESCRIPTION	DRAWN	APPROVED	DATE
-	-	-	-	-	-

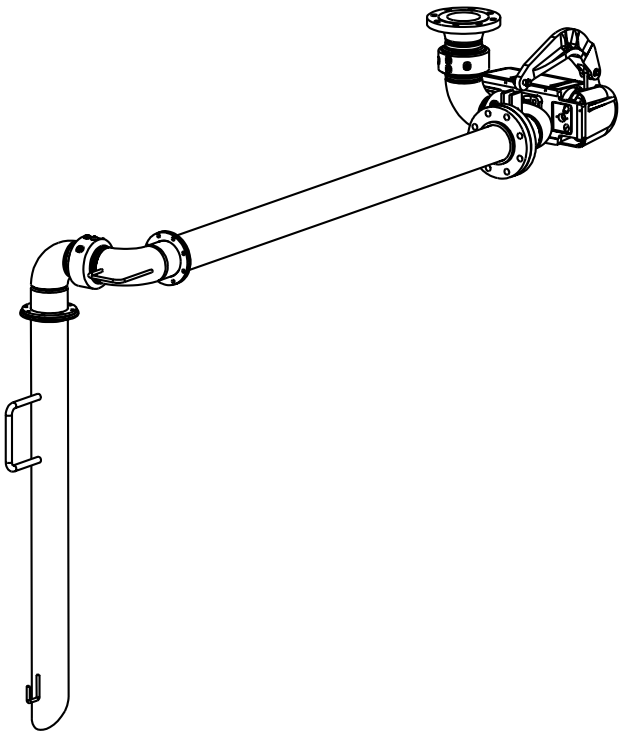
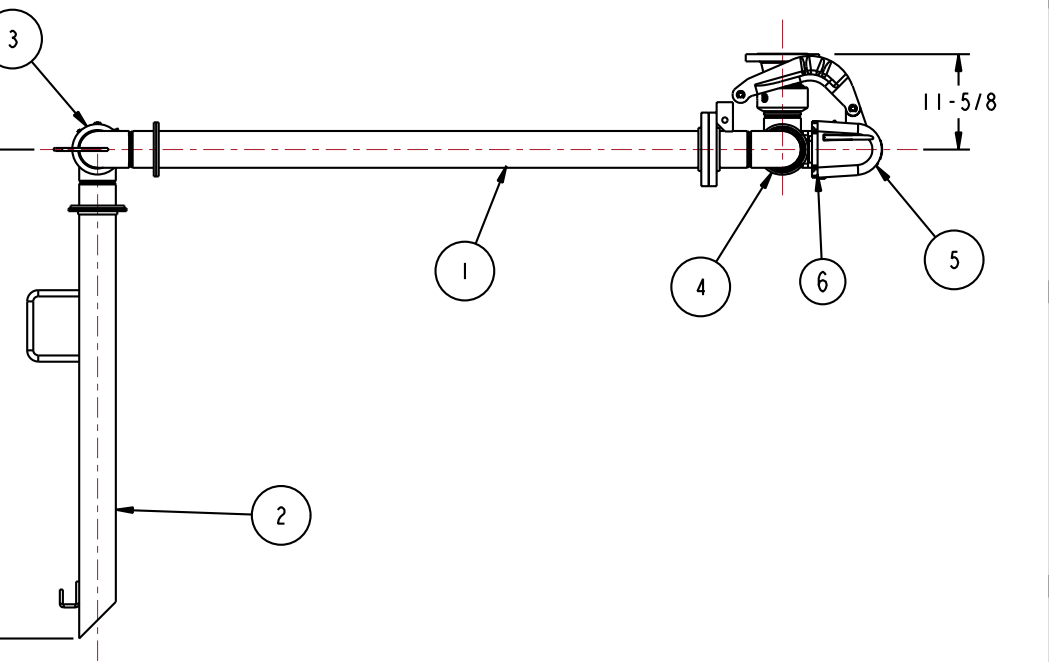
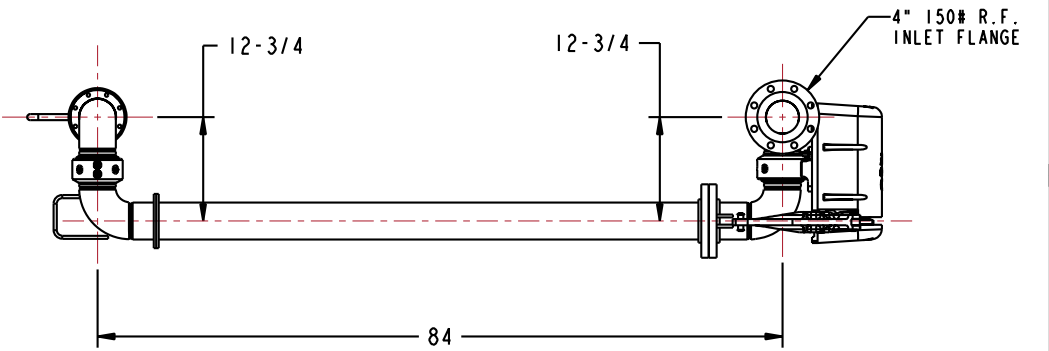

CONFIDENTIAL THIS DOCUMENT CONTAINS INFORMATION WHICH IS PROPRIETARY TO OPW, AND SHOULD BE PROTECTED ACCORDINGLY.

DESCRIPTION: 4" TOP LOADING ARM, DFLH

SIGNATURES	MO-DA-YR
DRAWN: BJB	2/26/10
CHECKED:	
MATERIAL:	WEIGHT:

REV: -	PART NUMBER:
SIZE: D	J33F-H855
SCALE: 0.090 SHEET 1 OF 3	

OPW Engineered Systems
A **ROBERT** Resources Company
Lebanon, Ohio 45036 USA
3D GENERATED DRAWING