

MATERIALS OF CONSTRUCTION	CARBON STEEL
SWIVEL JOINT SEALS	FLUOROCARBON GFLT
PRODUCT	ASPHALT
ESTIMATED WEIGHT	290 LBS
MOMENT LOAD AT SPRING	7,500 IN-LBS
FLANGE GASKETS	KLINGER SIL C5400
TEST PRESSURE	90 PSI
PRODUCT RETENTION	NO
WEIGHT BY OTHERS	TRACE & INSULATION @ 2.5 LBS/FT

6	I	EA	788L-0040	LOCKDOWN UNIT
5	I	EA	790C-0050	RIGHT HAND EZ ADJUST 'C' SPRING BALANCE
4	I	EA	3456FSBD-0402	4" SWIVEL, CST
3	I	EA	3444FT-A145	4" SWIVEL, CST
2	I	EA	N/A	4" CST PIPE SPOOL
1	I	EA	N/A	4" CST DROP PIPE SPOOL W/HANDLES
ITEM	QTY	UM	PART NUMBER	DESCRIPTION

THIS DRAWING IS NOT TO BE SCALED. FOR ADDITIONAL INFORMATION, PLEASE CONTACT OUR ENGINEERING DEPT.

REVISIONS					
LTR	ECN #	DESCRIPTION	DRAWN	APPROVED	DATE
-	-	-	-	-	-

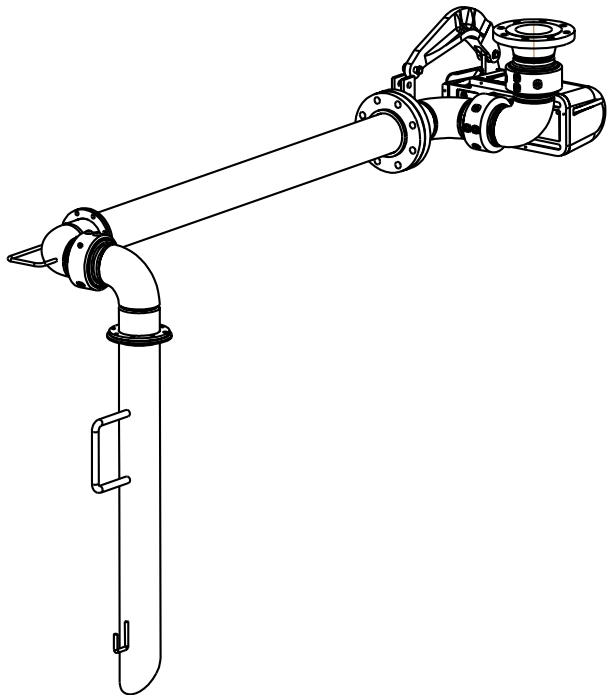
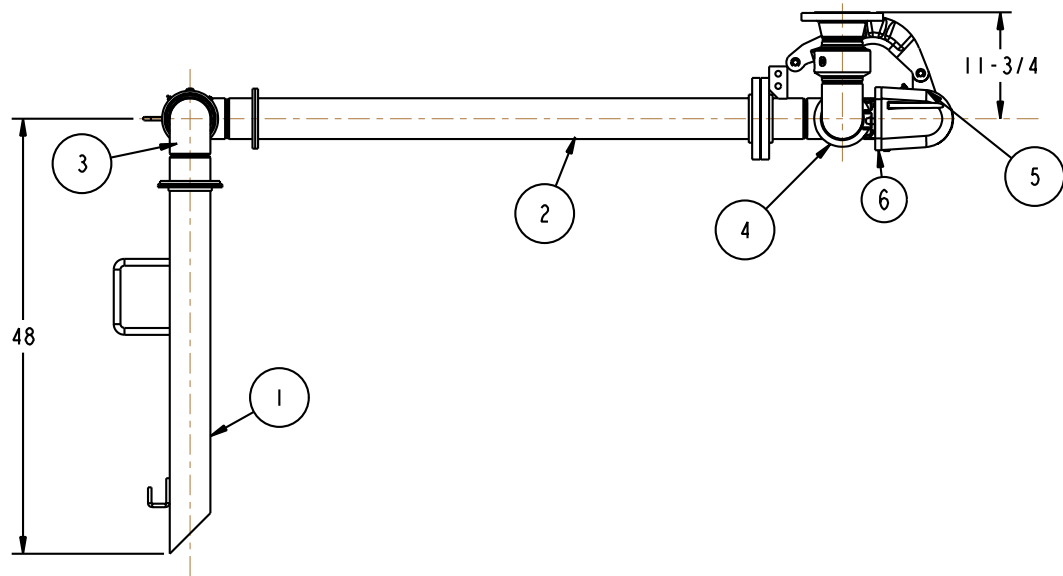
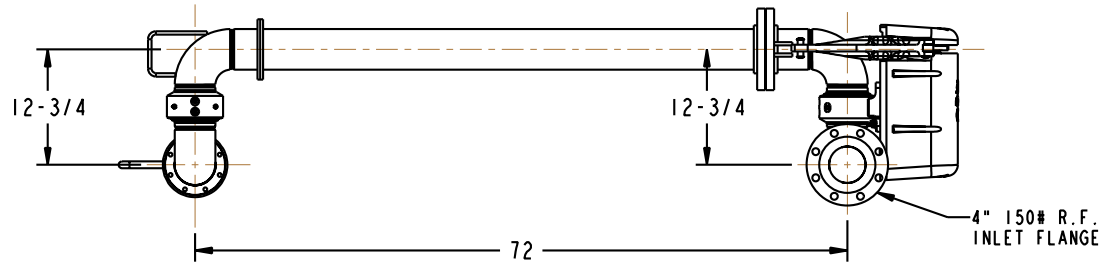

CONFIDENTIAL THIS DOCUMENT CONTAINS INFORMATION WHICH IS PROPRIETARY TO OPW, AND SHOULD BE PROTECTED ACCORDINGLY.

DESCRIPTION: 4" TOP LOADING ARM, DFRH

SIGNATURES		MO-DA-YR
DRAWN: JLP		12/07/09
CHECKED: -		-
MATERIAL:	WEIGHT:	-

REV: -  
SIZE: D

PART NUMBER:  
**J33F-H710**

**OPW Engineered Systems**  
A **ROBERT** Resources Company  
Lebanon, Ohio 45036 USA  
3D GENERATED DRAWING

SCALE: 0.100 SHEET 1 OF 3