

MATERIALS OF CONSTRUCTION	CARBON STEEL
SWIVEL JOINT SEALS	MAIN SEAL: FLUOROCARBON GFLT DUST SEAL: FLUOROCARBON GFLT
PRODUCT	ASPHALT
ESTIMATED WEIGHT	450 LBS
MOMENT LOAD AT SPRING	8000 IN-LBS
MOMENT LOAD AT INLET	25,700 IN-LBS
FLANGE GASKETS	GARLOCK GYLON 3500
TEST PRESSURE	90 PSI
PRODUCT RETENTION	NO
WEIGHT BY OTHERS	NONE

7	I	EA	790B-0030	RIGHT HAND EZ ADJUST 'B' SPRING BALANCE
6	I	EA	3456FSBD	4" SWIVEL, CST
5	I	EA	3440FTO	4" SWIVEL, CST
4	I	EA	3430FL	4" SWIVEL, CST
3	I	EA	N/A	4" CST OBR PIPE SPOOL
2	I	EA	N/A	4" CST IBR PIPE SPOOL
1	I	EA	N/A	4" CST DROP PIPE SPOOL
ITEM	QTY	UM	PART NUMBER	DESCRIPTION

THIS DRAWING IS NOT TO BE SCALED. FOR ADDITIONAL INFORMATION, PLEASE CONTACT OUR ENGINEERING DEPT.

REVISIONS					
LTR	ECN #	DESCRIPTION	DRAWN	APPROVED	DATE
-	-	-	-	-	-

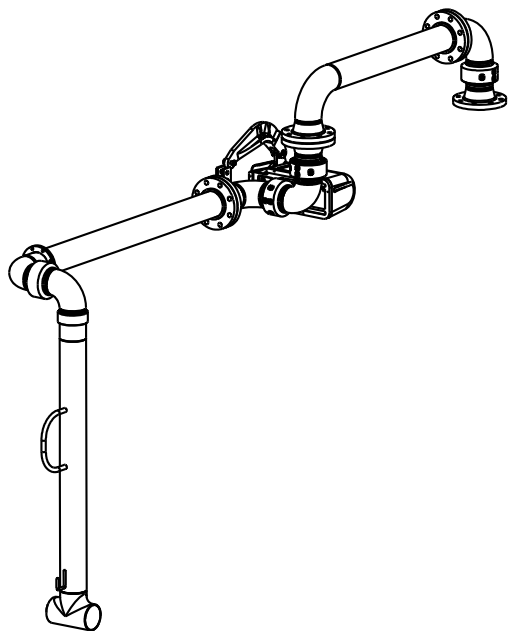
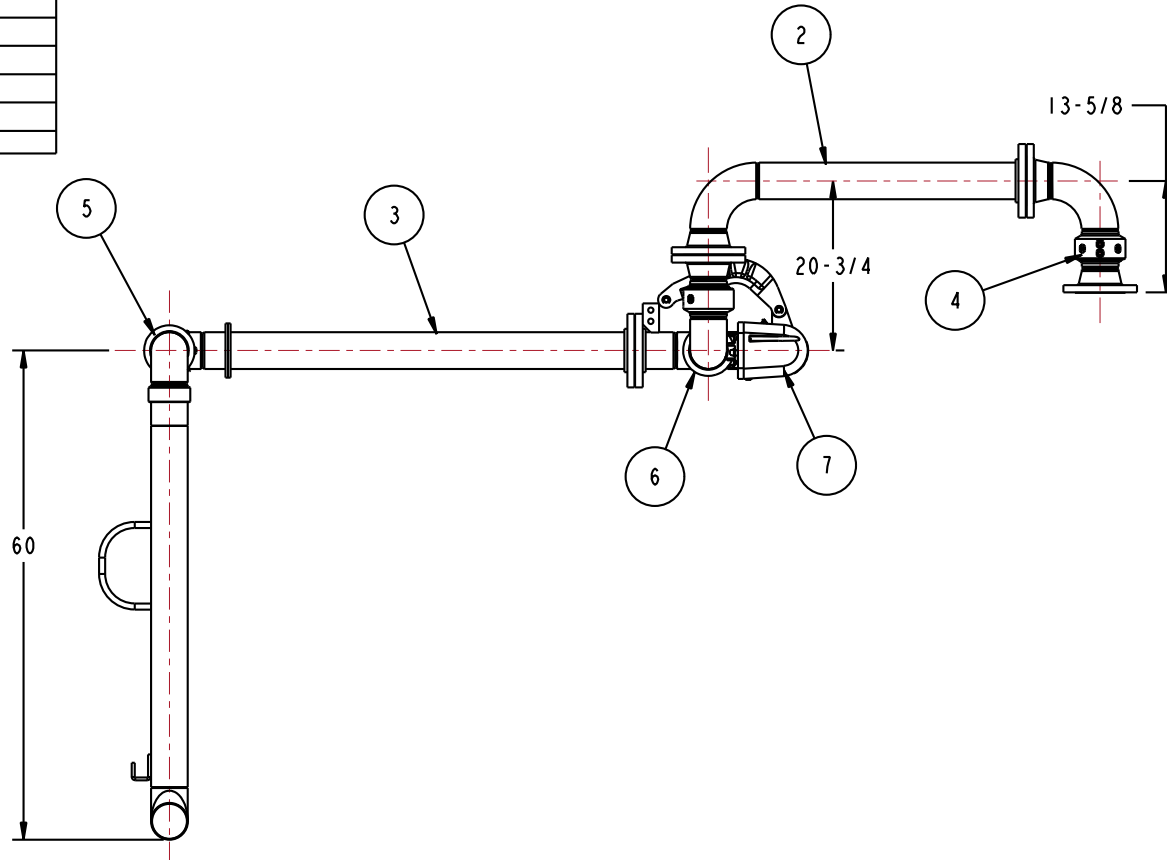
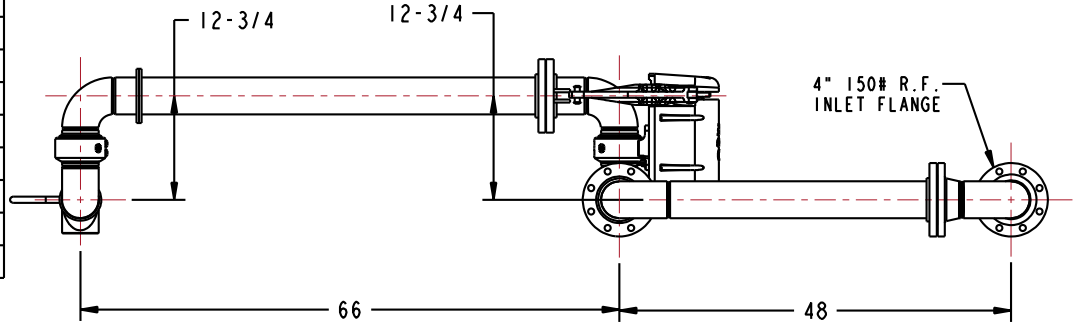

CONFIDENTIAL THIS DOCUMENT CONTAINS INFORMATION WHICH IS PROPRIETARY TO OPW, AND SHOULD BE PROTECTED ACCORDINGLY.

DESCRIPTION: 4" TOP LOADING ARM, DFRH

SIGNATURES		MO-DA-YR
DRAWN: BJB		3/22/10
CHECKED:		
MATERIAL:	WEIGHT:	

REV: -	PART NUMBER:
SIZE: D	<b>GT33F-H886</b>
SCALE: 0.090 SHEET 1 OF 4	

**OPW Engineered Systems**  
A **ROBERT** Resources Company  
Lebanon, Ohio 45036 USA  
3D GENERATED DRAWING