

MATERIALS OF CONSTRUCTION	CARBON STEEL
SWIVEL JOINT SEALS	MAIN SEAL: FLUOROCARBON GFLT DUST SEAL: FLUOROCARBON GFLT
PRODUCT	ASPHALT
ESTIMATED WEIGHT	450 LBS
MOMENT LOAD AT SPRING	6350 IN-LBS
MOMENT LOAD AT INLET	19,075 IN-LBS
FLANGE GASKETS	KLINGER SIL C5400
TEST PRESSURE	90 PSI
PRODUCT RETENTION	NO
WEIGHT BY OTHERS	TRACING & INSULATION @ 2.5 LBS/FT

8	I	EA	788L-0040	LOCKDOWN UNIT
7	I	EA	790A-0020	RIGHT HAND EZ ADJUST 'A' SPRING BALANCE
6	I	EA	3456FSBD	4" SWIVEL, CST
5	I	EA	3440FTO	4" SWIVEL, CST
4	I	EA	3430FL	4" SWIVEL, CST
3	I	EA	N/A	4" CST OBR PIPE SPOOL
2	I	EA	N/A	4" CST IBR PIPE SPOOL
1	I	EA	N/A	4" CST DROP TUBE ASSY
ITEM	QTY	UM	PART NUMBER	DESCRIPTION

THIS DRAWING IS NOT TO BE SCALED. FOR ADDITIONAL INFORMATION, PLEASE CONTACT OUR ENGINEERING DEPT.

REVISIONS					
LTR	ECN #	DESCRIPTION	DRAWN	APPROVED	DATE
-	-	-	-	-	-

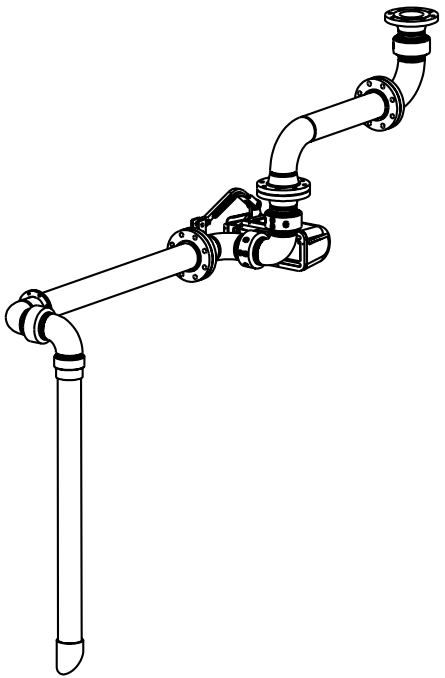
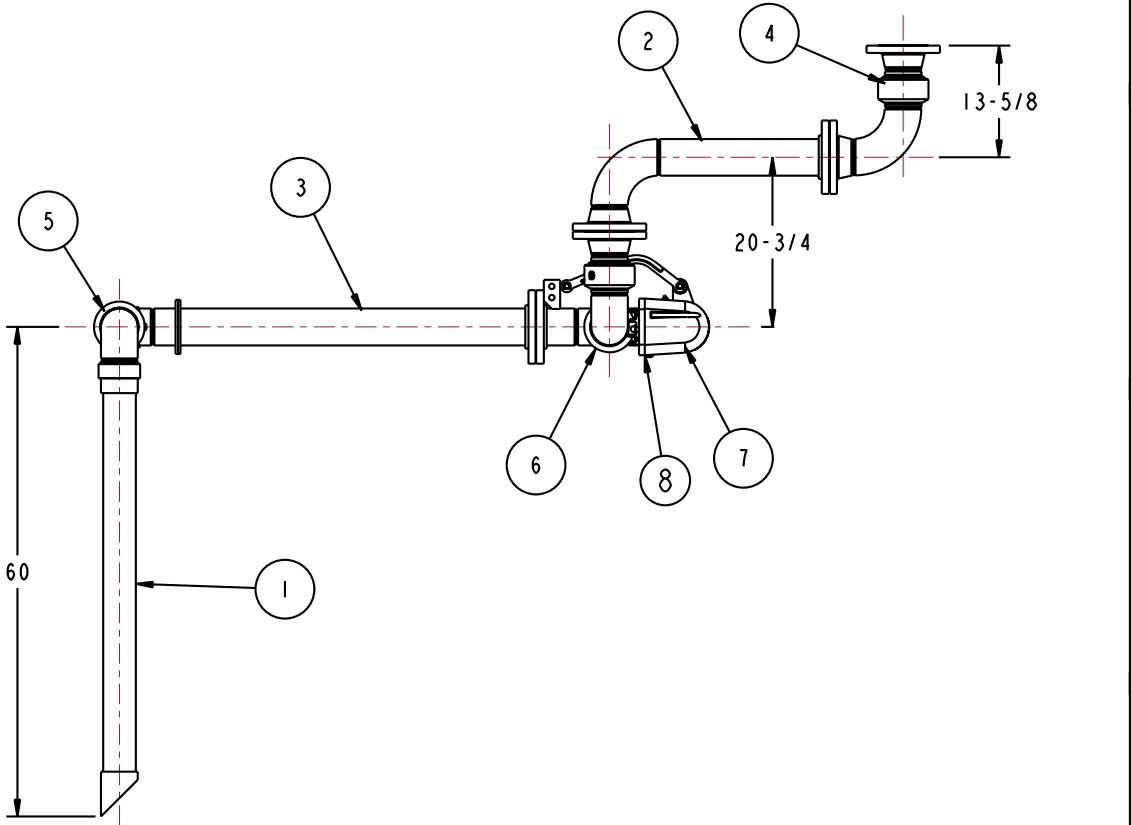
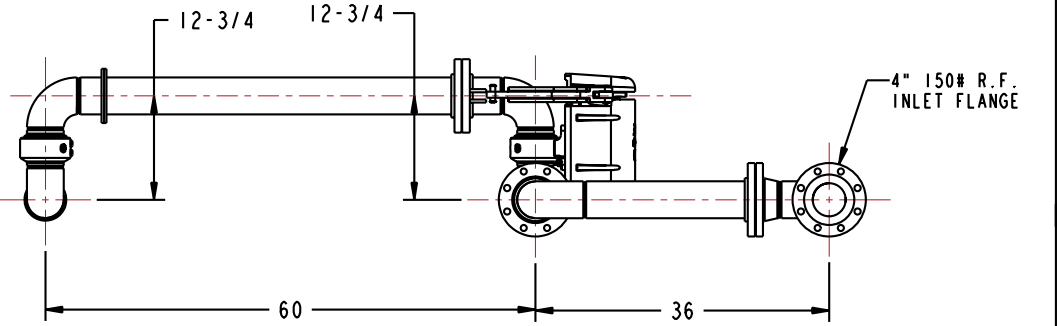

**CONFIDENTIAL** THIS DOCUMENT CONTAINS INFORMATION WHICH IS PROPRIETARY TO OPW, AND SHOULD BE PROTECTED ACCORDINGLY.

DESCRIPTION: 4" TOP LOADING ARM, DFRH

SIGNATURES	MO-DA-YR	REV:	PART NUMBER:
DRAWN: BJB	1/25/10	-	GT33F-H777
CHECKED:	-	SIZE:	D
MATERIAL:	WEIGHT:	SCALE: 0.090	SHEET 1 OF 3

OPW **Engineered Systems**  
A **ROBERT** Resources Company  
Lebanon, Ohio 45036 USA  
3D GENERATED DRAWING