

MATERIALS OF CONSTRUCTION	CARBON STEEL
SWIVEL JOINT SEALS	FLUOROCARBON GFLT
PRODUCT	ASPHALT
ESTIMATED WEIGHT	450 LBS
MOMENT LOAD AT SPRING	11,100 IN-LBS
FLANGE GASKETS	KLINGER SIL C5400
TEST PRESSURE	90 PSI
PRODUCT RETENTION	NO
WEIGHT BY OTHERS	INSULATION @ 2.5 LBS/FT

	6	EA	H30911M	3/4" STREET ELBOW
	2	EA	H30912M	SUPPLY/RETURN HOSE HOSE, 60" OAL
	2	EA	H30913M	JUMPER HOSE, 36" OAL
	4	I	EA 790C-0050	RIGHT HAND EZ ADJUST 'C' SPRING BALANCE
	3	I	EA 8458FS	4" SWIVEL ASSY, ENDURA DSF, CST, JKT'D
	2	I	EA 8240FW	4" SWIVEL ASSY, ENDURA DSF, CST
	1	I	EA HX98038	4" DUAL ELEMENT CONTRACE
ITEM	QTY	UM	PART NUMBER	DESCRIPTION

THIS DRAWING IS NOT TO BE SCALED. FOR ADDITIONAL INFORMATION, PLEASE CONTACT OUR ENGINEERING DEPT.

REVISIONS					
LTR	ECN #	DESCRIPTION	DRAWN	APPROVED	DATE
-	-	-	-	-	-

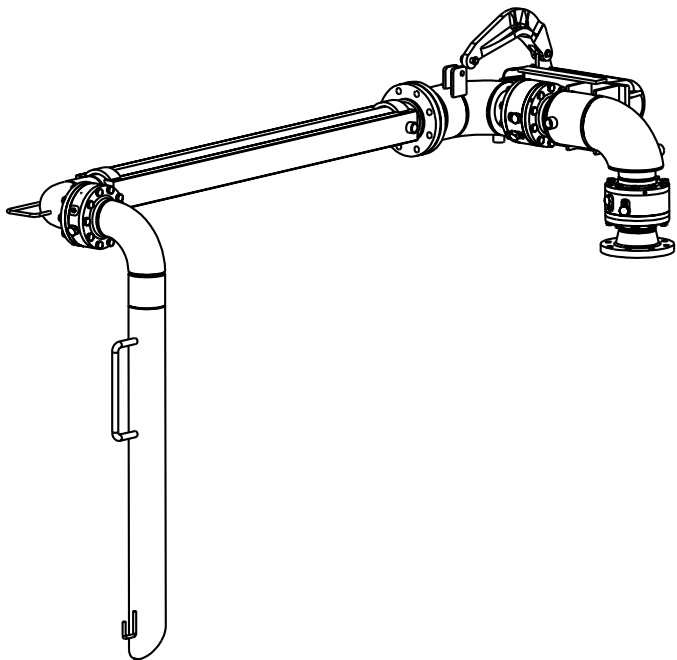
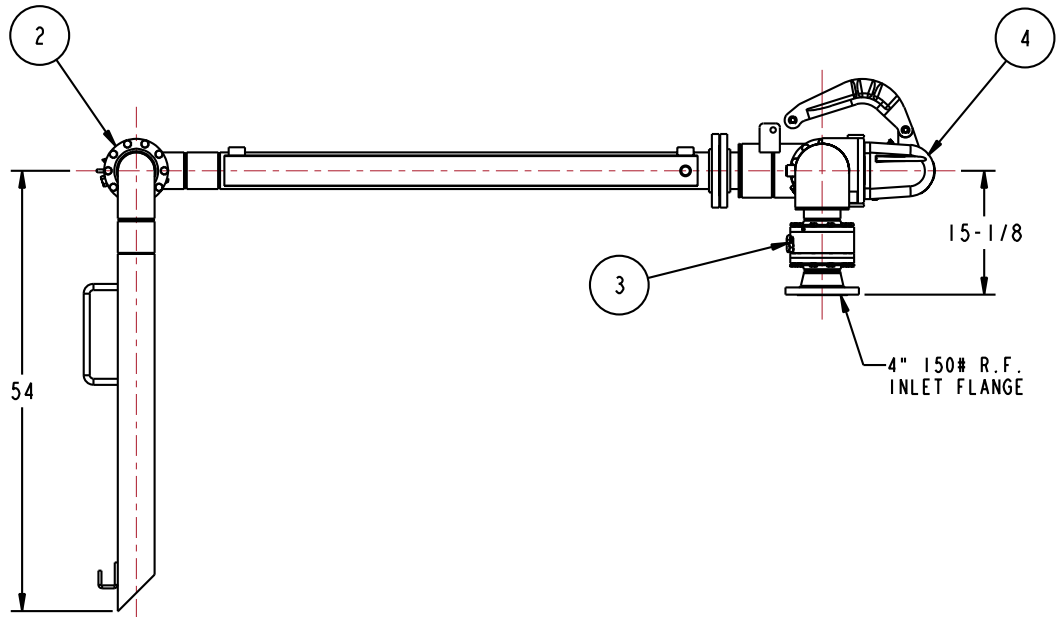
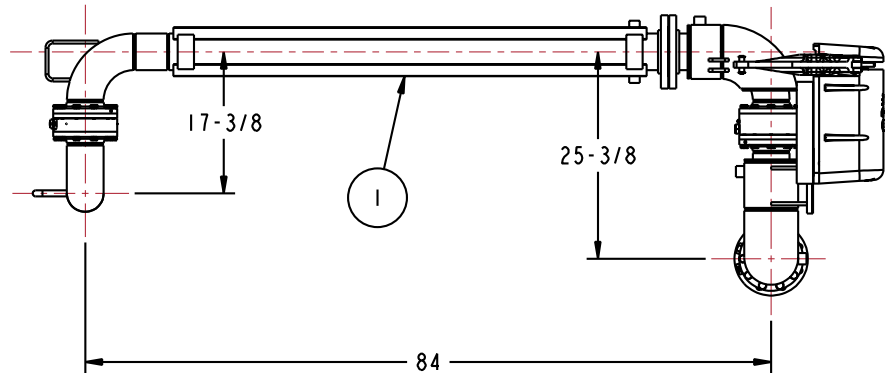

CONFIDENTIAL THIS DOCUMENT CONTAINS INFORMATION WHICH IS PROPRIETARY TO OPW, AND SHOULD BE PROTECTED ACCORDINGLY.

DESCRIPTION: 4" TOP LOADING ARM, UFRH, JACKETED

SIGNATURES		MO-DA-YR
DRAWN: BJB		11/23/09
CHECKED:		
MATERIAL:	WEIGHT:	

REV: -	PART NUMBER:
SIZE: D	EJ32F-H691
SCALE: 0.090	SHEET 1 OF 6

OPW Engineered Systems
 A **ROTTED** Resources Company
 Lebanon, Ohio 45036 USA
 3D GENERATED DRAWING