

MATERIALS OF CONSTRUCTION	CARBON STEEL
SWIVEL JOINT SEALS	VITON GFLT
PRODUCT	HOT TAR
ESTIMATED WEIGHT	300 LBS
MOMENT LOAD AT SPRING	4300 IN-LBS
FLANGE GASKETS	KLINGER SIL C5400
TEST PRESSURE	90 PSI
PRODUCT RETENTION	NO
WEIGHT BY OTHERS	INSULATION @ 2.5 LBS/FT
INTERNAL STEAM HOSES	BY OPW
STEAM SUPPLY & RETURN HOSES	BY OTHERS
STEAM CONNECTIONS	3/4" FNPT

6	I	EA	HX96033	BOLT ON JACKET FOR VALVE
5	I	EA	790A-0020	EZ ADJUST TORSION SPRING BALANCE
4	I	EA	HX96027	BALL VALVE, VELAN, STD PORT, CST, 2"
3	I	EA	8458FSB-G323	2" SWIVEL, ENDURA DSF, CST
2	I	EA	8440FW-G324	2" SWIVEL, ENDURA DSF, CST
1	I	EA	N/A	2" CST DROP PIPE W/HANDLE
ITEM	QTY	UM	PART NUMBER	DESCRIPTION

- H30314M 8 BOLT
- H04740M 8 NUT
- H01507M 8 WASHER
- H06090M 2 GASKET
- H02209PA 1 INSTRUCTION SHEET
- H30446M 1 ALUM NAME PLATE
- H30447M 2 SST TIE BANDS
- H30913M 4 JUMPER HOSE 36" OAL
- H30912M 1 JUMPER HOSE 60" OAL
- H30911M 12 3/4" STREET ELBOW

THIS DRAWING IS NOT TO BE SCALED. FOR ADDITIONAL INFORMATION, PLEASE CONTACT OUR ENGINEERING DEPT.

REVISIONS					
LTR	ECN #	DESCRIPTION	DRAWN	APPROVED	DATE

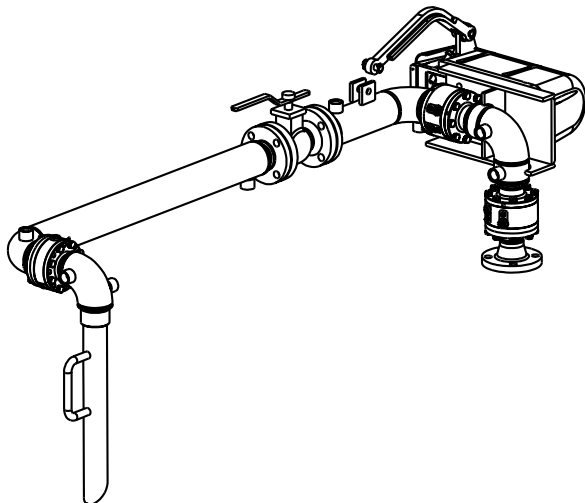
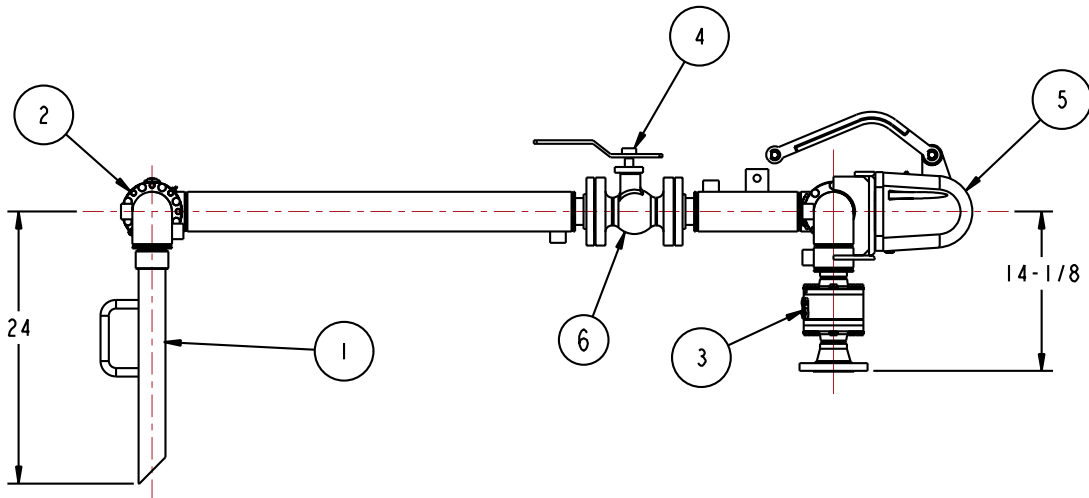
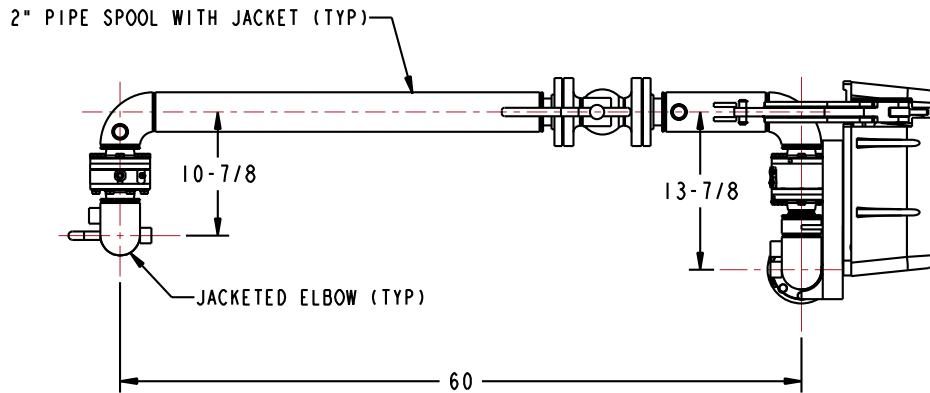

**CONFIDENTIAL** THIS DOCUMENT CONTAINS INFORMATION WHICH IS PROPRIETARY TO OPW, AND SHOULD BE PROTECTED ACCORDINGLY.

UNLESS OTHERWISE SPECIFIED TOLERANCES ON DIMENSIONS 3 DECIMALS +/- 0.005 2 DECIMALS +/- 0.015 1 DECIMAL +/- 0.030 ANGLES +/- 1/2 DEG MACHINED SURFACES 125 RMS MAX
--

SIGNATURES		MO-DA-YR	REV:	DESCRIPTION: 2" LOADING ARM, JACKETED	
DRAWN: BJB		4/3/08	-	PART NUMBER:	OPW <b>Engineered Systems</b>
CHECKED:			SIZE: D	<b>EJ32F-G322</b>	A <b>ROTTED</b> Resources Company
MATERIAL:	WEIGHT:			SCALE: 0.125	Lebanon, Ohio 45036 USA
				SHEET 1 OF 5	3D GENERATED DRAWING