

A B C D E

MATERIALS OF CONSTRUCTION	STAINLESS STEEL
SWIVEL JOINT SEALS	FLUOROCARBON
PRODUCT	MONOMER & QUAT
ESTIMATED WEIGHT	210 lbs.
MOMENT LOAD AT SPRING	4,950 inlbs.
MOMENT LOAD AT INLET	SAME
FLANGE GASKETS	KLINGER SIL 5400
TEST PRESSURE	90 psi
PRODUCT RETENTION	YES, UP TO THE BALL VALVE
WEIGHT BY OTHERS	VALVE BY OTHERS 8LBS

THIS DRAWING IS NOT TO BE SCALED. FOR ADDITIONAL INFORMATION, PLEASE CONTACT OUR ENGINEERING DEPT.

REVISIONS					
LTR	ECN #	DESCRIPTION	DRAWN	APPROVED	DATE
-	-	-	-	-	-

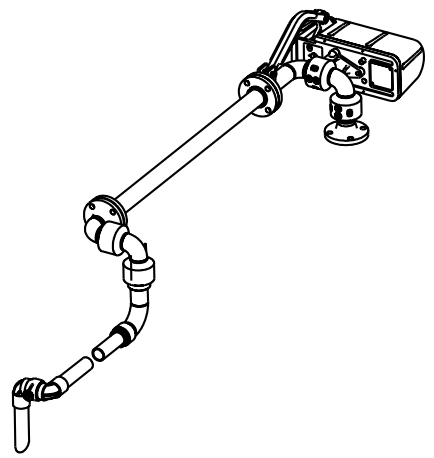
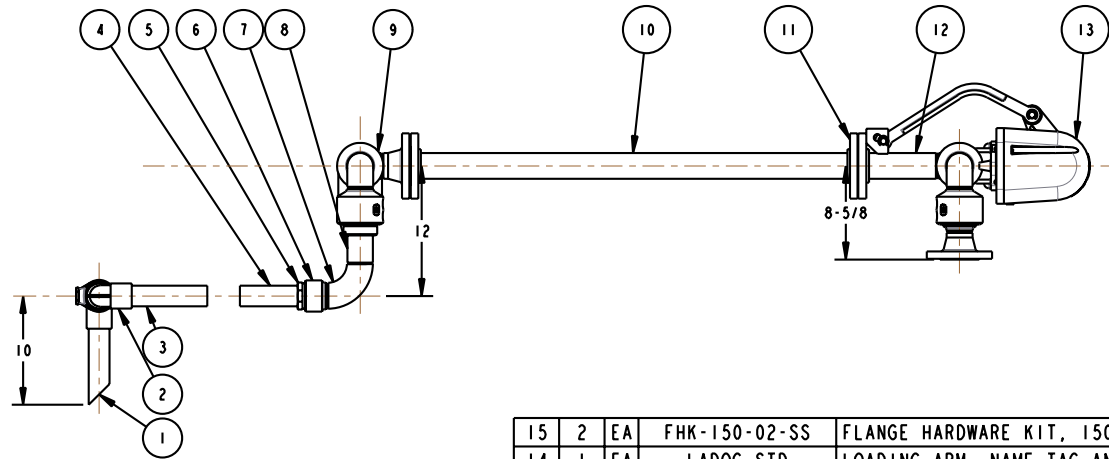
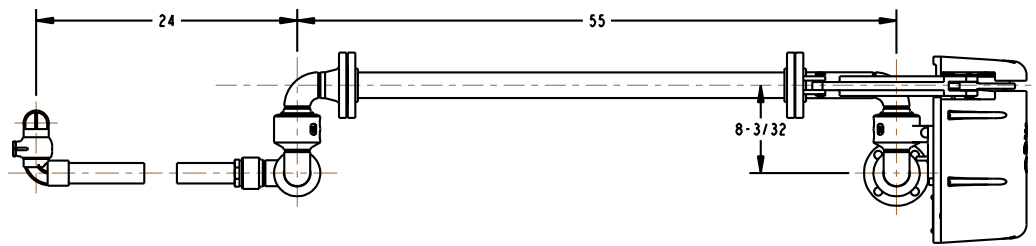

ITEM	QTY	UW	PART NUMBER	DESCRIPTION
15	2	EA	FKH-150-02-SS	FLANGE HARDWARE KIT, 150LB, SS, 2"
14	1	EA	LADOC-STD	LOADING ARM, NAME TAG AND HARDWARE
13	1	EA	790A-0020	RIGHT HAND EZ ADJUST 'A' SPRING
12	1	EA	3958FSB-0202	2" SWIVEL, SST, FLUOROCARBON
11	2	EA	H30463M	FLG, 150, RFSO, SST, 2"
10	1	EA	HX98862	2" S40 SST PIPE
9	1	EA	39500F-0202	2" SWIVEL, SST, FLUOROCARBON
8	1	EA	HX98862	2" SCH40 SST PIPE
7	1	EA	H-30372-M	ELBOW, LR, S40, SST, 2"
6	1	EA	H-7746-EW	WELDING COUPLER, SST, 2"
5	1	EA	H-08977-M	REDUCER BUSHING, 2" X 1.5", SST
4	1	EA	HX98862	1-1/2" SCH40 SST PIPE
3	1	EA	HX98862	1-1/2" SST SCH40 PIPE
2	1	EA	3740-0152	1-1/2" SWIVEL, SST
1	1	EA	HX98810	1-1/2" SST PIPE

CONFIDENTIAL THIS DOCUMENT CONTAINS INFORMATION WHICH IS PROPRIETARY TO OPW, AND SHOULD BE PROTECTED ACCORDINGLY.

SIGNATURES		MO-DA-YR	REV:	DESCRIPTION: 2" SST LOADING ARM, UFRH	
DRAWN:	JLP	8/20/10	-	PART NUMBER:	OPW <b>Engineered Systems</b>
CHECKED:	-	-	SIZE:	<b>C32F-J163</b>	A <b>ROTEX</b> Resources Company
MATERIAL:	SST	WEIGHT:	D	SCALE: 0.120	Lebanon, Ohio 45036 USA
				SHEET 1 OF 2	3D GENERATED DRAWING

1 2 3 4 5