

Issue Date: January 11, 2021

# VISI-FLO® SIGHT FLOW INDICATORS



## Installation, Operation & Maintenance (IOM) Manual



**OPW**   
ENGINEERED SYSTEMS  
a **DOVER** company

[opw-es.com](http://opw-es.com)

**ENGINEERING | WHAT'S NEXT**



OPW Engineered Systems specializes in the engineering, designing and manufacturing of systems for the safe and efficient loading and unloading of critical hazardous materials: loading systems, swivel joints, instrumentation, quick and dry disconnect systems and safety breakaways.

## Contents

VISI-FLO® Sight Flow Indicators Datasheet .....	3
Technical Information .....	4-6
1400 / 1500 Maintenance .....	6-10
1400 / 1500 Parts Overview.....	11
1400 / 1500 Testing Procedures .....	11



**IMPORTANT:** OPW products should be used in compliance with applicable federal, state, provincial, and local laws and regulations. Product selection should be based on physical specifications and limitations and compatibility with the environment and materials to be handled. OPW MAKES NO WARRANTY OF FITNESS FOR A PARTICULAR USE. All illustrations and specifications in this literature are based on the latest product information available at the time of publication. OPW reserves the right to make changes at any time in prices, materials, specifications and models and to discontinue models without notice or obligation.

# VISI-FLO® Sight Flow Indicators Datasheet

OPW Engineered Systems has been manufacturing sight flow indicators for over 60 years. Our experience has led to many innovations in design and manufacturing, making VISI-FLO® the most thoroughly engineered sight flow indicator on the market. VISI-FLOs are available in two series: the Standard 1400 Series, and the 1500 High-Pressure, High-Temperature Series.

## Benefits

- **Exclusive 3-Year "No-Leak" Guarantee** - VISI-FLO's innovative radial seal design creates a constant and uninterrupted sealing force between the body and the outside diameter of the glass lens. This sealing method provides a longer lasting and better seal than conventional flat seals, common with tie-rod designs.
- **Dimensionally Interchangeable** - with most competitive units (FJP Units).
- **No Maintenance Required** - VISI-FLO's unique, bolt-on body design requires no special maintenance or torquing sequence. This results in a safer, more reliable sight flow indicator than units using tie rods to fasten lens and seal to body.
- **Rated for Vacuum Service** - up to 635 mm (25") of Hg (Mercury) at 85.5% vacuum. This equates to 12.3 psi vacuum.



VISI-FLO® Sight Flow Indicators

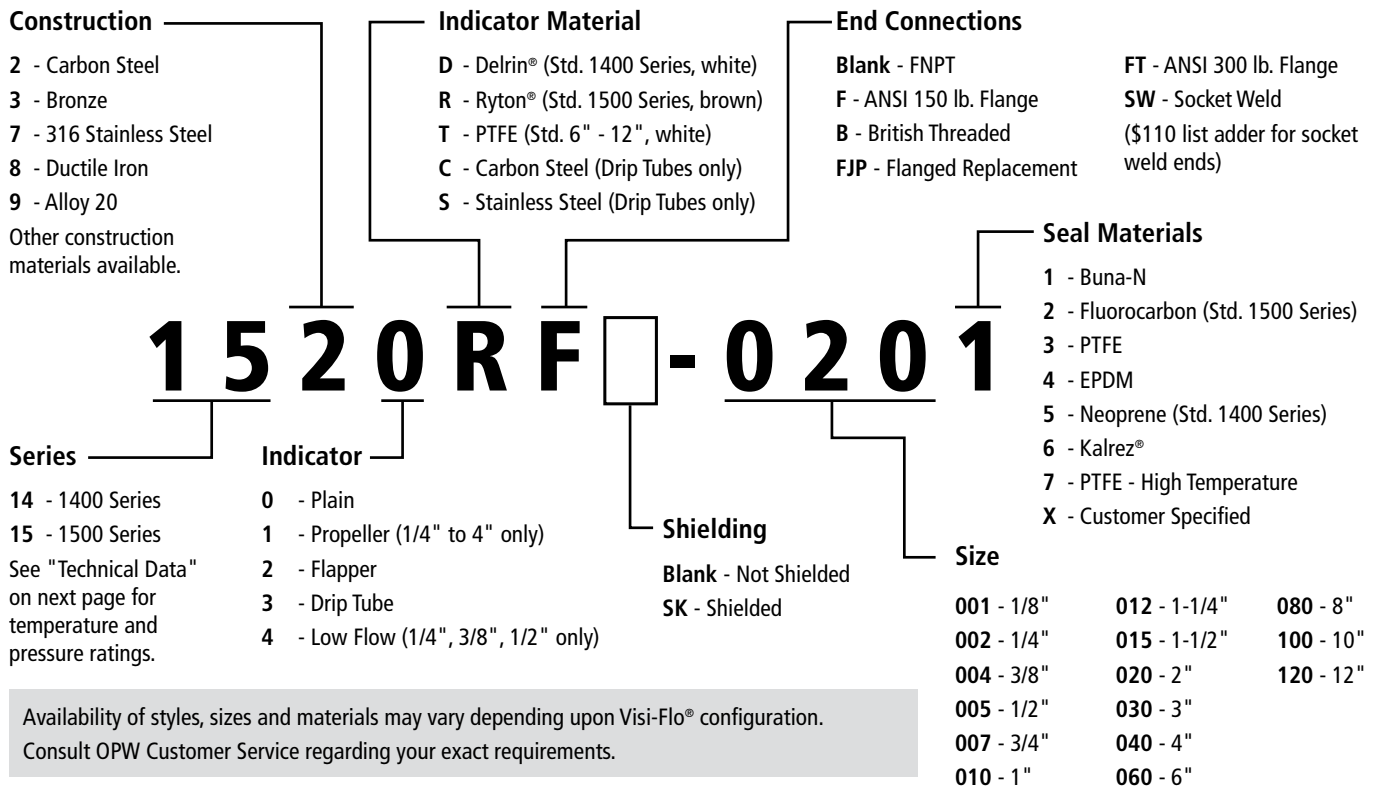

# Technical Information

## Construction and Material

<b>Body:</b>	Steel	ASTM A216 WCB
	316 Stainless Steel	ASTM A351 CF8M
	6" and larger	ASTM A351 CF3M (316L)
	Ductile Iron	ASTM A536 65-45-12
	Bronze	ASTM B62 83600
	Optional Materials:	Hastelloy®, Alloy® 20, Monel®, Others upon request
<b>Windows:</b>	1400 Series (1/4" - 2")	Tempered Soda Lime
	1400 Series (3" and Above)	Annealed Soda Lime
	1500 Series	Tempered Borosilicate
<b>Indicators:</b>	1400 Series	Delrin®
	1500 Series	Ryton®
	Optional Materials:	PTFE
<b>Seals:</b>	1400 Series	Neoprene (Std.)
	1500 Series	Fluorocarbon (Std.)
<b>Connections:</b>	1400 Series	ASME B1.20 FNPT
		ASME B16.5 150RF
		ASME B1.20 FNPT
		ASME B16.5 150RF
	Options: Socket Weld BSP	ASME B16.11 ASME BS21
<b>Options:</b>	Protective Shield (1400SK):	Polycarbonate Lens Cover
	Pressure/Temperature Probe:	Consult Factory

## Seal and Indicator Operating Temperatures

Material	Degrees F	Degrees C
Neoprene (1400 Series standard)	-20 to 250	-29 to 121
Fluorocarbon (1500 Series standard)	-20 to 400	-29 to 204
Buna-N	-20 to 212	-29 to 100
EPDM	-50 to 250	-46 to 121
PTFE	-40 to 400	-40 to 204
Kalrez®	0 to 500	-18 to 260
Hi-Temp PTFE / Kalrez®	-40 to 500	-40 to 260
<b>Indicators</b>		
Delrin®	-40 to 250	-40 to 121
Ryton®	-40 to 450	-40 to 232
PTFE	-40 to 500	-40 to 260

## Service Rating

VISI-FLO®	Max. Pressure	Max. Temperature <sup>1</sup>
1400 Series Threaded/Flanged (1/4"-4")	200 PSIG @ 150°F	250°F @ 135 PSIG
1400 Series Flanged (6"-12")	150 PSIG @ 150°F	150°F @ 150 PSIG
1500 Series Threaded (1/4"-2")	400 PSIG @ 150°F	400°F @ 160 PSIG
1500 Series Flanged (3/4"-4")	285 PSIG @ 100°F <sup>4</sup>	400°F @ 200 PSIG <sup>3</sup>
1500 Series Flanged (6"-12")	275 PSIG @ 100°F	400°F @ 200 PSIG <sup>2</sup>

<sup>1</sup> With standard seals    <sup>2</sup> Stainless-steel units rated @ 195 PSIG    <sup>3</sup> Stainless-steel units rated @ 195 PSIG, ductile iron @ 150 PSIG    <sup>4</sup> Stainless-steel units rated @ 275 PSIG, ductile iron @ 245 PSIG

### Notes:

- Alternate seals may result in higher operating temperatures
- Temperatures up to 500° F possible with Hi-Temp PTFE seals

# Technical Information

## Flow Charts

### VISI-FLO with Propeller Indicator

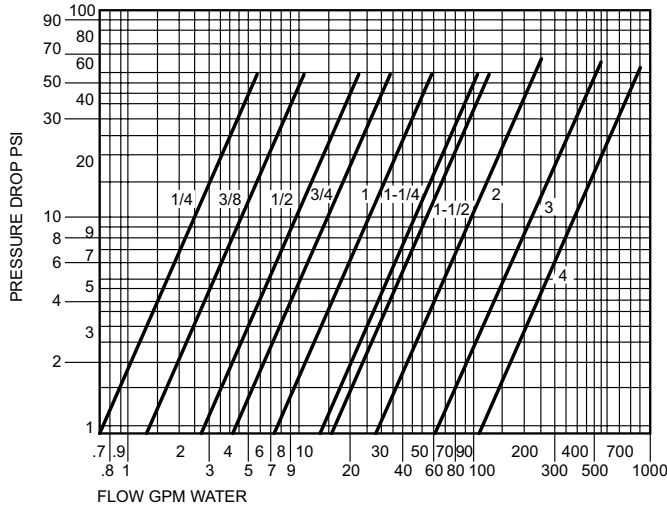

NOTE: Over 100 gpm Flapper indicator advised

### VISI-FLO with Flapper or Drip-Tube Indicators & Plain

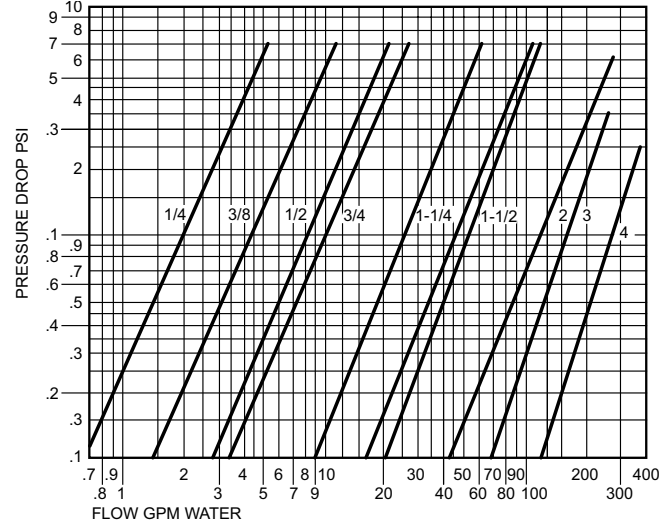

Minimum Flow\* Required to Turn Propeller

Size	1/4"	3/8"	1/2"	3/4"	1"	1-1/4"	1-1/2"	2"
GPM	.14	.25	.30	.60	.7	1.05	1.25	1.30

\* VISI-FLO installed in horizontal position with deflector opening down.

1435 (Low-Flow Orifice Plate) Minimum Flow Requirement to Turn Propeller

Size	1/4"	3/8"	1/2"
GPM	.08	.09	.11

DIMENSIONAL DRAWINGS ARE AVAILABLE FROM THE DOWNLOAD SECTION OF OUR WEBSITE - WWW.OPW-ES.COM

## Shield Kits

### 1400SK - 1720

Shield Kit, 1400 & 1500 Series

Size

- 1720 = 1/4", 3/8", 1/2"
- 1740 = 3/4", 1"
- 1770 = 1-1/4", 1-1/2", 2"
- 1790 = 3", 4"
- 1800 = 6", 12"

**NOTE:**  
All Shield Kits include Shield (1) & Mounting Hardware

## Seal Repair Kits

### 1400 RK - 005 1

Series

- 14 = 1400 Series
- 15 = 1500 Series

RK

Repair Kit

Size

- 005 - 1/4", 3/8", 1/2"
- 010 - 3/4", 1"
- 020 - 1-1/4", 1-1/2", 2"
- 040 - 3", 4"
- 060 - 6", 12"

Seal Materials

- 1 = Buna
- 2 = Fluorocarbon (Viton)
- 3 = PTFE
- 4 = EPDM
- 5 = Neoprene

**NOTES:**  
1. Original seal material should be stamped on unit nameplate.  
2. All kits include top & bottom seals, glass, gaskets & instruction sheet

# 1400 / 1500 Maintenance

## Shield Kit Installation

- 1 With wrench, remove one bolt only from face plate
- 2 Insert stud into open hole and turn to approximately four (4) turns
- 3 Place lock washer under nut on stud and tighten
- 4 Repeat steps 1, 2 and 3 in that order on second face plate bolts
- 5 Install shield on stud extension, resting shield on the nuts already tightened in place
- 6 Install hold down nuts on shield

## Installation Instructions

- 1 Before installation, the user should check the unit for damage during shipping and freedom from defects such as lens scratches or chips.
- 2 Check and remove any foreign material inside the VISI-FLO.
- 3 Determine direction of flow and install the unit according to the arrow stamped on nameplate.

- Note:**
- If unit is to be installed in a location or position where objects could strike the unit, a 1400 SK Shield Kit is recommended.
  - The VISI-FLO is not designed to be a load bearing component, therefore the piping should be supported accordingly.
  - Position the specific models as follows:
    - Plain VISI-FLO can be mounted in any plane or position
    - Propeller unit can be mounted in any plane or position (except horizontal with nameplate facing down)
    - Drip tube model must be mounted vertically with flow downward
    - Flapper model should be mounted horizontally or vertically with flow upwards

## Maintenance

### BEFORE YOU BEGIN CONSIDER THE FOLLOWING:

- 1 Periodic inspection (every 3 months for leakages is recommended.)
- 2 Maintenance must be performed by authorized personnel
- 3 Before performing any maintenance on sight flow indicator, the full installation must be shut down/off before proceeding.
- 4 Do not attempt any maintenance or servicing without reading this entire manual.  
**When any leaks are found, have seals replaced immediately.**

## Disassembly Instructions (Units up to 2")

### Step 1:

- For drip tube units, begin by removing the drip funnel
- Note: The drip funnel will require that you push it out from the opposite end with some sort of rod. Be sure to use something relatively soft, so as not to damage any components inside the VISI-FLO®

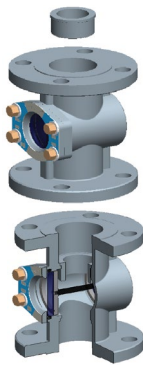

### Step 2:

- Remove the bolts, washers, nameplate, plate, and gasket

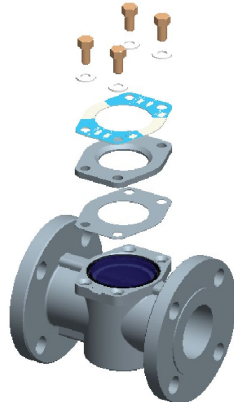

### Step 3:

- Remove the O-rings, spacers, bridges and shaft, propeller / flapper (does not apply to drip tube units), and glass plates
- You can apply moderate pressure to the bottom glass and it should push everything above it out
- If this does not work, then you may have to remove the top O-ring with a pick made of soft brass or aluminum
- If this is the case, discard the removed O-ring as it may have been damaged, and replace it with a new one
- Thoroughly clean all sealing surfaces with a non-abrasive cleaning pad

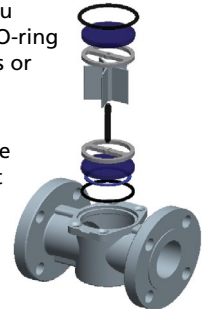

**WARNING:** 1) Do not attempt any maintenance service while the equipment is in operation. System pressure must be relieved and the product drained before attempting any service on the unit. The line must be locked out while service is in progress. Proper thermal relief must be provided at all times while equipment is being serviced.

Failure to follow these warnings could result in serious personal injury, property damage or product failure.

- 2) OPW products do not eliminate possible exposure to hazardous substances. The conditions of handling and use are beyond our control, and we make no guarantee and assume no liability for damages or injuries related to the use of our products. Follow the safety precautions outlined in the Material Safety Data Sheets for the material being used. It is the responsibility of the user to comply with all federal, state and local regulations. Always employ proper safety precautions and handling techniques.
- 3) Proper seal and wetted material part selection is critical for safe operation. To assure maximum life for the service intended, use only those materials compatible with the fluids being handled. Please note material being supplied and make certain that it is suited for the intended service.
- 4) OPW VISI-FLOs are NOT recommended for compressed gas (i.e. air, nitrogen, etc.) applications.

# 1400 / 1500 Maintenance

## Assembly Instructions (Units up to 2")

### Step 1:

- Install flow director, (propeller unit only)

Single Plate VISI-FLO units  
(Up to 2" in Size)

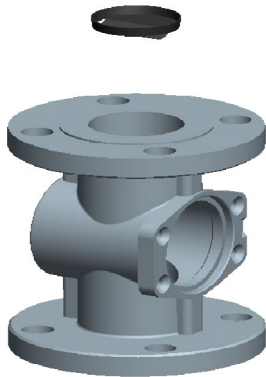

### Step 4:

- Note: Propeller unit shown
- Drop propeller or flapper onto shaft
- Drip tube units skip this step

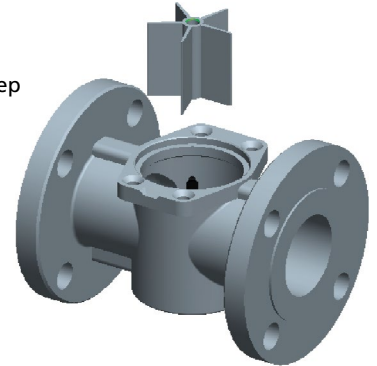

### Step 2:

- Lightly lubricate seals with a light oil
- Press seal into body, install PTFE spacer so it is concentric to seal
- (PTFE spacer fits inside seal)

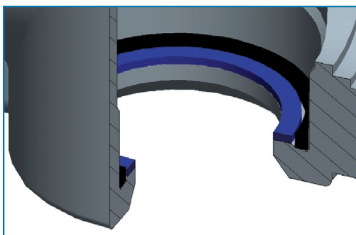
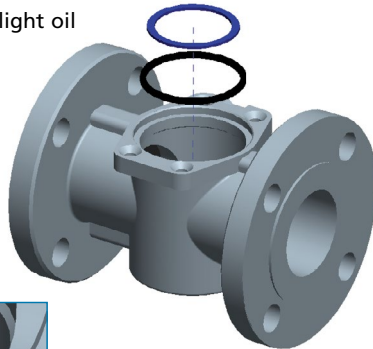

**NOTE:** EPDM seals are NOT compatible with petroleum-based lubricants. A silicone-based lubricant must be used with EPDM.

### Step 5:

- Note: Propeller unit shown
- Orient second bridge so center boss faces inward
- Press onto shaft until shoulder on shaft touches boss

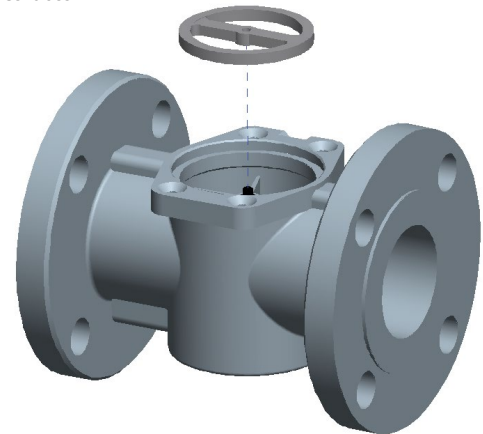

### Step 3:

- Drop glass on top of seal and spacer, followed by bridge/shaft assembly
- Be sure that beveled edge of glass faces retaining bridge

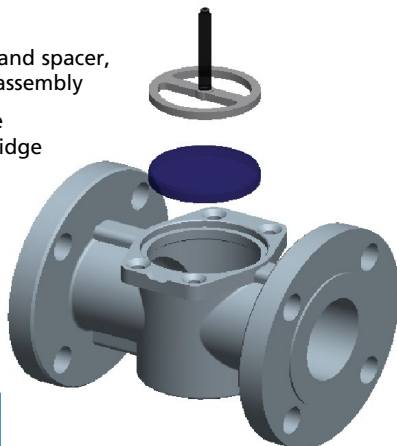

Beveled Edge

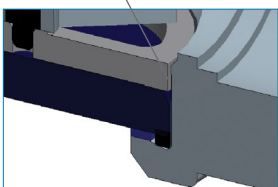

### Step 6:

- Lightly lubricate O-ring with light oil before pressing into ridge

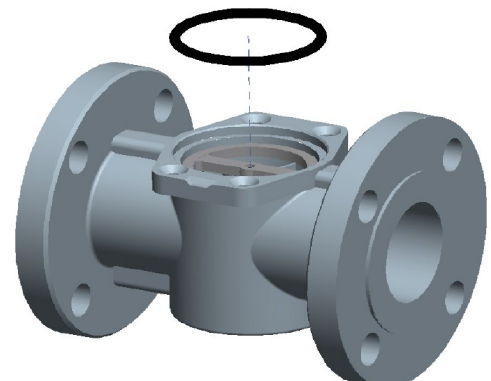

**NOTE:** EPDM seals are NOT compatible with petroleum-based lubricants. A silicone-based lubricant must be used with EPDM.

# 1400 / 1500 Maintenance

## Assembly Instructions (Units up to 2") Continued

### Step 7:

Press glass inside O-ring making sure beveled edge of glass is facing towards retaining bridge.

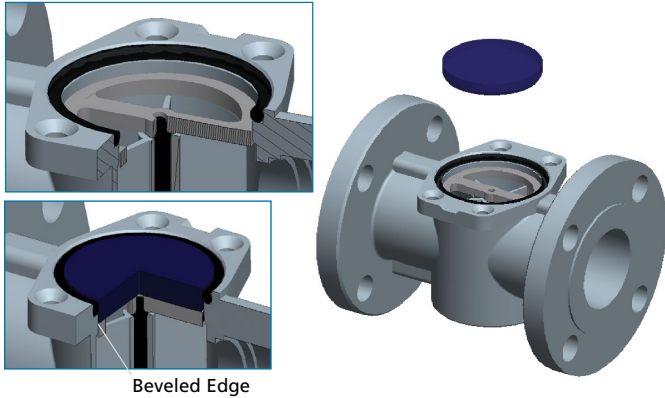

Beveled Edge

### Step 10:

• Drip Tube Versions Only: Drop bushing into body, either side is fine, and press into place so shoulder on bushing touches shoulder inside body

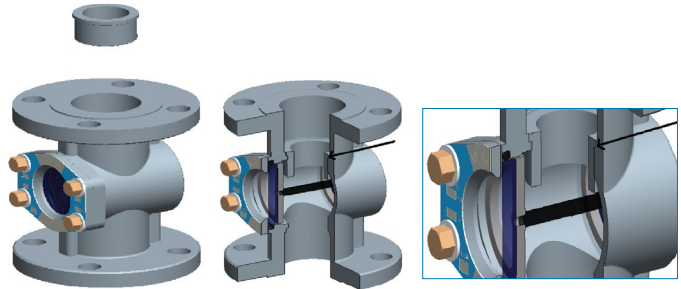

### Step 8:

- Place gasket, plate and nameplate over glass
- Make sure chamfer in the center of the plate faces away from the glass

**NOTE:** Chamfer must be facing up

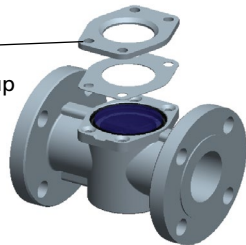

### Step 9:

- Flow direction starts on the end with flow director and passes through the unit
- Hand-tighten bolts with wrench only
- Propeller units only: Make sure to orient nameplate so flow direction arrow is correct

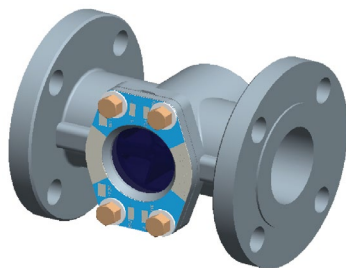
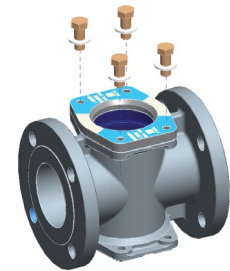

## Assembly Complete!



**WARNING:** 1) Do not attempt any maintenance service while the equipment is in operation. System pressure must be relieved and the product drained before attempting any service on the unit. The line must be locked out while service is in progress. Proper thermal relief must be provided at all times while equipment is being serviced.

Failure to follow these warnings could result in serious personal injury, property damage or product failure.

- 2) OPW products do not eliminate possible exposure to hazardous substances. The conditions of handling and use are beyond our control, and we make no guarantee and assume no liability for damages or injuries related to the use of our products. Follow the safety precautions outlined in the Material Safety Data Sheets for the material being used. It is the responsibility of the user to comply with all federal, state and local regulations. Always employ proper safety precautions and handling techniques.
- 3) Proper seal and wetted material part selection is critical for safe operation. To assure maximum life for the service intended, use only those materials compatible with the fluids being handled. Please note material being supplied and make certain that it is suited for the intended service.
- 4) OPW VISI-FLOs are NOT recommended for compressed gas (i.e. air, nitrogen, etc.) applications.



# 1400 / 1500 Maintenance

## Detailed Disassembly (3" & Above)

### Step 1:

- Remove bolts, washers, nameplate, plate, and gasket



### Step 2:

- Remove glass and O-ring
- Repeat process for other side
- Thoroughly clean all sealing surfaces with a non-abrasive cleaning pad

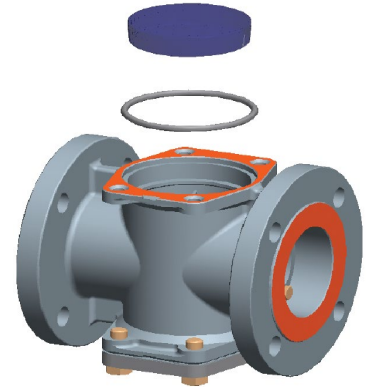

## Assembly Instructions (Units 3" & up)

### Step 1:

- Make sure that flapper or propeller (whichever is being installed) is assembled as shown

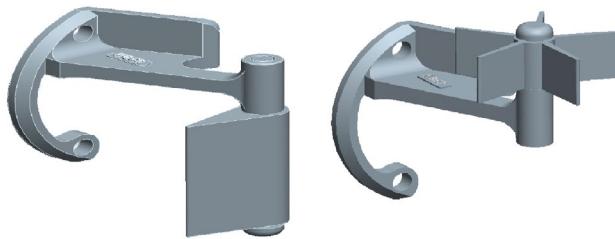

### Step 4:

- Press drip tube into end opposite bolt hole ears
- 3" and 4" SST have Teflon insert. All other 3" and over are welded

NOTE: 3" and 4" carbon-steel VISI-FLO's drip tube is welded in place.

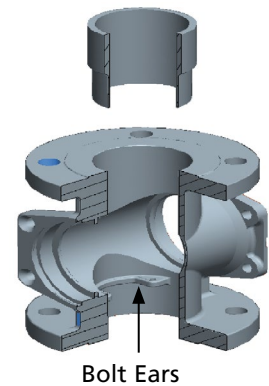

### Step 2:

- Fit flapper or propeller assembly down into body so bolt holes on support arm match with bolt ears on body

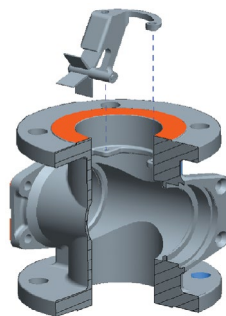

### Step 5:

- Propeller version shown
- For flapper or propeller versions, start with whichever side exposes indicator retainer button
- Lightly lubricate O-ring with light oil before pressing it into ridge
- If building drip tube version you may begin with either side

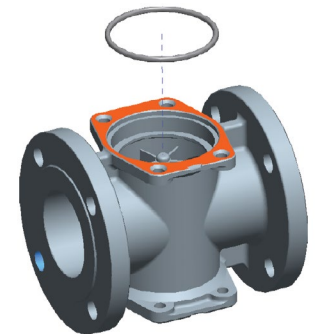

### Step 3:

- Secure with lock washers and bolts

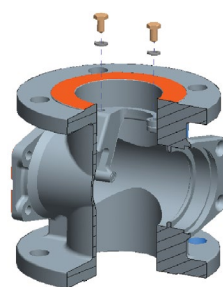

NOTE: EPDM seals are NOT compatible with petroleum-based lubricants. A silicone-based lubricant must be used with EPDM.

# 1400 / 1500 Maintenance

## Assembly Instructions (Units 3" & up) Continued

### Step 6:

- Wedge beveled glass down inside O-ring, with the smallest diameter towards the center
- Once glass begins to resist further seating, stop

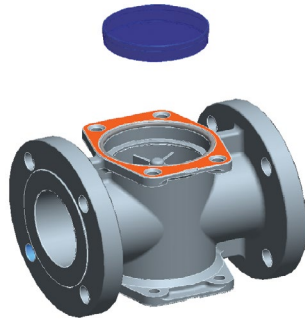

### Step 9:

- Place nameplate on top of compressed components with flow direction facing the correct way
- Flow direction for propeller version can be determined by looking through VISI-FLO
- Flow starts on the side with bolt ears, and travels through to the opposite side
- Drip tube version is opposite this
- Flapper units do not have a flow direction

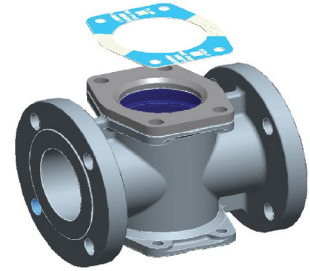

### Step 7:

- Place one gasket and plate over glass
- Make sure chamfered side of the plate faces up

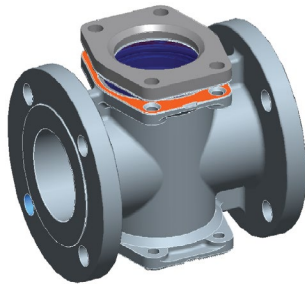

### Step 10:

- Secure components with bolts and flat washers
- Hand-tighten with wrench only
- Repeat on opposite side.

**Assembly Complete!**

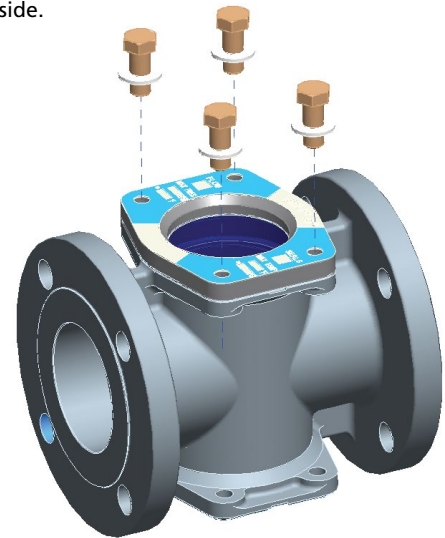

### Step 8:

- With your palm, press down with even pressure until glass seats and gasket bottoms out

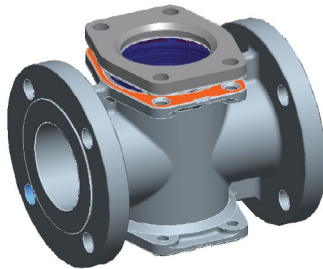

**WARNING:** 1) Do not attempt any maintenance service while the equipment is in operation. System pressure must be relieved and the product drained before attempting any service on the unit. The line must be locked out while service is in progress. Proper thermal relief must be provided at all times while equipment is being serviced.

Failure to follow these warnings could result in serious personal injury, property damage or product failure.

2) OPW products do not eliminate possible exposure to hazardous substances. The conditions of handling and use are beyond our control, and we make no guarantee and assume no liability for damages or injuries related to the use of our products. Follow the safety precautions outlined in the Material Safety Data Sheets for the material being used. It is the responsibility of the user to comply with all federal, state and local regulations. Always employ proper safety precautions and handling techniques.

3) Proper seal and wetted material part selection is critical for safe operation. To assure maximum life for the service intended, use only those materials compatible with the fluids being handled. Please note material being supplied and make certain that it is suited for the intended service.

4) OPW VISI-FLOs are NOT recommended for compressed gas (i.e. air, nitrogen, etc.) applications.

# 1400 / 1500 Parts Overview and Testing Procedures

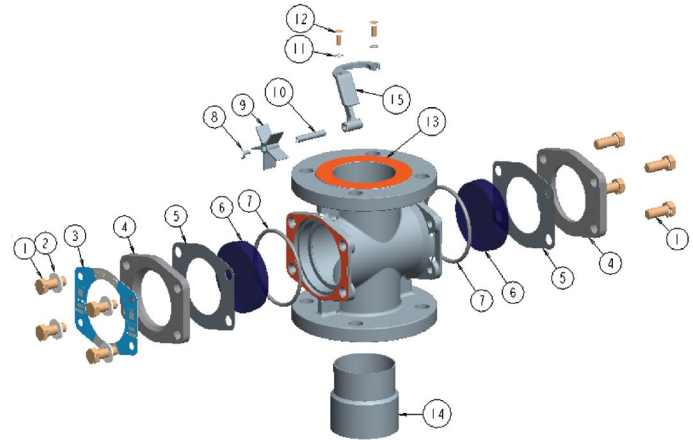
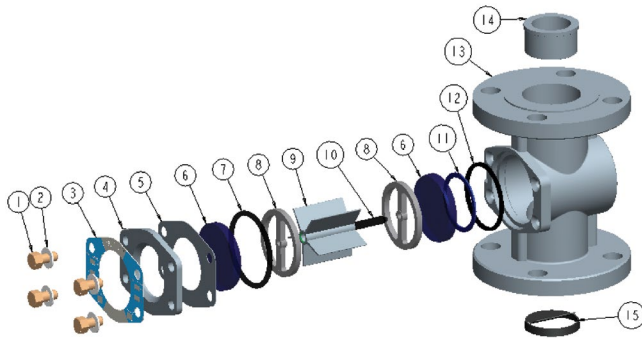

Key	Description	Series	1/4", 3/8" & 1/2"	3/4" & 1"	1 1/4", 1 1/2" & 2"	
1	Retaining Bolt	1400	H40190M	H40191M	H40191M	
		1500	H30497M	H30498M	H30498M	
2	Washer	1400 & 1500	H40193M	H40194M	H40194M	
3	Nameplate	1400 & 1500	H30756M	H30757M	H30758M	
4	Cap, Plated Steel	1400	H2888M	H2889M	H2890M	
		1500	H30448M	H30449M	H30450M	
5	Gasket*	1400 & 1500	H3870M	H3871M	H3873M	
6	Glass*	1400	H5997M	H6001M	H10152M	
		1500	H5998M	H6002M	H10153M	
7	Seal*	See Repair Kits				
8	Retaining Bridge (2 required per unit)	1400 & 1500	H5996M	H6000M	H6004M	
9	Indicator					
		Propeller-Delrin	1400	H40153M	H40152M	H40141M
		Propeller-Ryton	1500	H2910M	H2911M	H2912M
		Propeller-PTFE	1400 & 1500	H40171M	H40172M	H40173M
		Flapper-Delrin	1400	H40150M	H40149M	H40148M
		Flapper-Ryton	1500	H2944M	H2947M	H2948M
10	Shaft	1400 & 1500	H40196M	H40197M	H40198M	
		1400 & 1500	H5999M	H6003M	H6011M	
11	Seal*	See Repair Kits				
12	Spacer, PTFE*	1400 & 1500	H31752M	H31753M	H31636M	
13	Body					
14	Drip Tube	1400 & 1500	H30357RS	H30359RP	H30354RP	
15	Deflector (propeller units only)	1400 & 1500	H5012M	H5018M	H5020M	

Key	Description	Series	3" & 4"	6" - 12"	
1	Retaining Bolts	1400 & 1500	H-40192-M	H-40109-M	
2	Washers	1400 & 1500	H40195M	H40194M	
3	Nameplate	1400 & 1500	C20190M	C20191M	
4	Cap, Plated Steel	1400 & 1500	C-20136-M	C-30012-RS	
5	Gasket*	1400 & 1500	H3874M	H40108M	
		1400	C00665M	H40107M	
6	Glass*	1500	C00667M	H30368M	
7	Seals*	See Repair Kits			
8	Button, PTFE	1400&1500	H40157P	H40117RP	
9	Indicator				
		Propeller-Delrin	1400	H40154P	NA
		Propeller-Ryton	1500	H40158P	NA
		Propeller-PTFE	1400 & 1500	H40174M	NA
		Flapper-Delrin	1400	H40148M	NA
		Flapper-Ryton	1500	H2948M	NA
10	Shaft	1400 & 1500	H40155M	H40116RE	
11	Lockwasher, SST	1400 & 1500	H5162M		
12	Retaining Screw/Bolt	1400 & 1500	H40155M	H40144RP	
13	Body				
14	Drip Tube				
15	Indicator Support Arm	1400 & 1500	C30025EW	H40114RS	

\*Included in 1400RK/1500RK Seal Kits

## Test Procedures 1400 / 1500

	MAX PRESSURE (PSI)	TEST PROCEDURE	ANSI RATED?
1/4" - 2" Threaded 1400 Series	200	A	Yes
1/4" - 2" Threaded 1500 Series	600	B	Yes (to 400 psi only)
1" - 12" Threaded 1400 & 1500 Series	200/275	C	Yes*

\*All flanged VISO-FLO meet requirements for 150 lb. ANSI Flanges

**A** = Test at 160 psi +/- 25 psi for one minute. Test at 400 psi +/- 50 psi for one minute.

**B** = Test at 160 psi +/- 25 psi for one minute. Test at 650 psi +/- 50 psi for one minute

**C** = Test at 500 psi +/- 50 psi for a period of time specified as per ANSI: 1", 1 1/2", 2" sizes for a minimum of 1 minute. 3", 4", 6" and 8" sizes for a minimum of 2 minutes. 10" and 12" sizes for a minimum of 3 minutes.

\*Quantity required for applicable models.

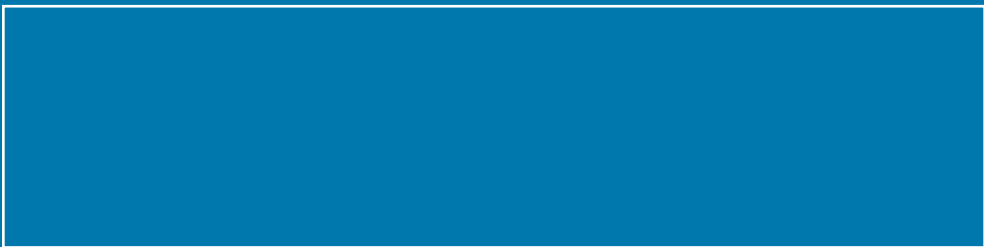

[www.opw-es.com](http://www.opw-es.com) ◆ 2726 Henkle Drive ◆ Lebanon, Ohio 45036 ◆ Phone: (513) 932 9114 ◆ Fax: (513) 932 9845

NOTE: All information subject to engineering and/or other changes. All trade names are copyrighted. Patents Pending. ©2021 OPW Engineered Systems. ©2021 Delaware Capital Formation, Inc. All Rights Reserved. DOVER and the DOVER logo are registered trademarks of Delaware Capital Formation, Inc., a wholly-owned subsidiary of Dover Corporation.