

10 PLUS Series* Emergency Shut-Off Valves

IMPORTANT: Please read all warnings and follow the installation instructions completely and carefully. Failure to do so will void all warranties and may cause product failure, or result in environmental contamination due to liquid leakage into the soil, creating hazardous conditions.

WARNING: Anytime an OPW 10 Series Emergency Valve is being tested or serviced, the power to the pumping system must be turned off.

WARNING: Using electrically- operated equipment near gasoline or gasoline vapors may result in a fire or explosion, causing personal injury and property damage. Be sure that the working area is free from such hazards, and always use proper precautions.

WARNING: Proper operation is dependent on proper installation and regular maintenance. The following instructions are provided to assist you in properly installing and maintaining your 10 PLUS Valve. Failure to follow these instructions may cause failure of the valve to close in the event of an emergency, resulting in a hazardous condition.

The shear groove must be at the same level or a maximum of 1/2" above or below the top of the grade or top of island. Failure to install the shear groove at this level may result in a hazardous condition. (On 10P series the shear groove is centered in the SmartGuard area.)

CAUTION: The hub sub-assembly and link must have ample clearance to prevent striking against foreign objects or structures. If the lever or link is obstructed the valve may not close in the event of an emergency resulting in a hazardous condition. OPW recommends a minimum of 1" of clearance surrounding any moving external parts.

The valve body must be rigidly anchored to a structural member within the island to ensure breakage at the shear groove in the event of impact. Failure to rigidly anchor the valve body may result in an excessive loss of product and may cause a hazardous condition.

IMPORTANT NOTICE: When mounting the OPW 10 Series Emergency Shut-Off Valves, the anchoring device employed must withstand a force greater than 650 ft. pounds per valve. Stabilizer mounting bolts are provided with each valve.

OPW RECOMMENDED INSTALLATION

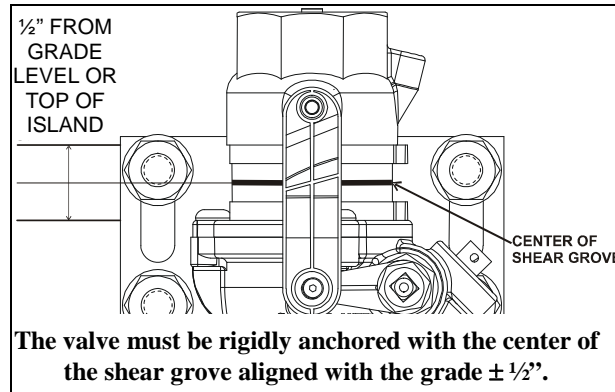

Figure 1

HOW TO ATTACH VALVE TO RISER THREADS

Coat riser threads with a UL classified gasoline-resistant pipe-joint compound (non-hardening) before attaching the valve to the riser threads.

DO NOT USE TEFLON TAPE

Thread valve tightly onto riser threads by grasping inlet end surface "A". (See Figure 2.)

A thread protector is supplied in the outlet end of the valve and should remain in place until the final connection is made between the valve and pedestal.

CAUTION: Tighten threads until tight seal is obtained. Additional tightening may cause the body to crack and may allow product leakage during test or in service. (TORQUE SPECIFICATIONS 125-135 FOOT POUNDS)

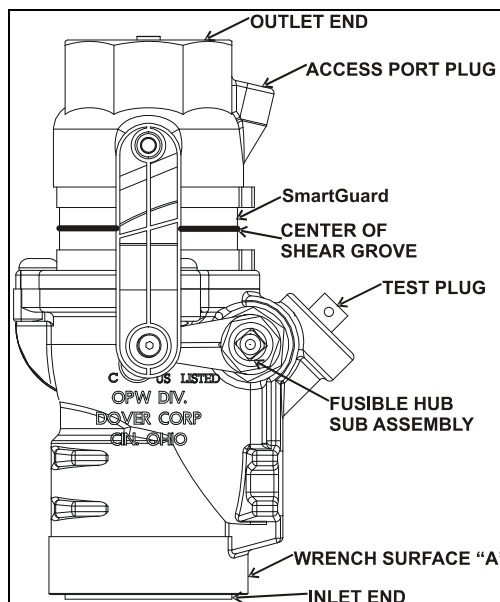

Figure 2

* Listed by Underwriters Laboratories

CAUTION: Do not attempt to tighten valve onto riser by wrenching above the shear section. This could cause the shear section to fracture or break. Tighten on Wrench Surface “A”

HOW TO ATTACH OUTLET OF VALVE TO DISPENSER PIPING

Hold valve steady with one wrench on Wrench Surface “F” – if this wrench is turned the shear section may fracture or crack (See Figure 3). A second wrench is used to tighten the pipe being attached.

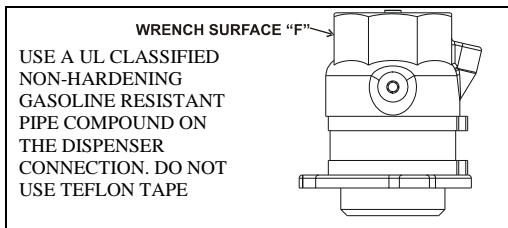

Figure 3

WARNING: Anytime an OPW 10 Series Emergency Valve is being tested or serviced, the power to the pumping system must be turned off.

REQUIRED MAINTENANCE

The service application of this valve requires that it do nothing until it is needed in the event of an emergency. Therefore, to provide for proper action in event of an emergency, the following procedure is required:

At least once each year, manually open and close the valve several times by actuating the hub using a 11/16 box-ended wrench to help prevent gum deposit build-up and/or other conditions that may affect the operation of the valve.

To check the integrity of the SmartGuard remove access port plug (BE SURE NOT TO REMOVE THE TEST PORT PLUG) (See Figure 2) and pressurize with no more than 10 psi. To put the SmartGuard back in place when testing is complete you can either pull a vacuum or gently use your finger. Be careful not to damage the SmartGuard. To ensure proper SmartGuard operation, do not apply pipe joint compound or teflon tape to the access port plug. Failure to put the access plug back into the access port will cause the SmartGuard to not function. Torque the access plug 10 in-lbs.

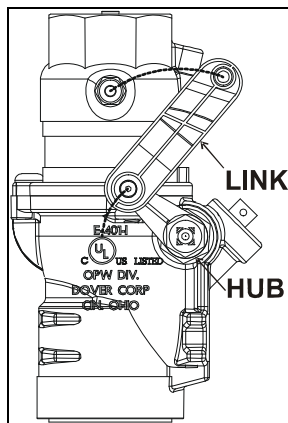

Figure 4A
(Valve in closed position)

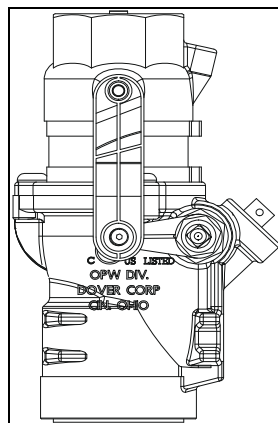

Figure 4B
(Valve in open position)

HOW TO OPEN 10P SERIES VALVE MANUALLY

After the valve has been attached to riser and pedestal piping, and pressure testing is completed, it should be cocked open. To open the valve, rotate the hub counter clockwise with the link perpendicular. (See Figure 4A) Once the hub is fully rotated insert the pin into the hole on the link (See Figure 4B). Do NOT use pliers or a screwdriver. Use an 11/16 box-ended wrench.

HOW TO SHUT OFF 10P VALVES MANUALLY

To shut off the 10P valves manually push the link (200518) away from the valve body.

PRESSURE TESTING THE PIPING SYSTEM

Before pressure testing ensure SmartGuard access port plug is present and installed properly. See Figure 2 for access port plug location. If access port plug is missing the SmartGuard will not function properly. To ensure proper SmartGuard operation, pipe joint compound or teflon tape **MUST** not be present on the access port plug (See Figure 5). If present pipe joint compound or Teflon tape must be completely removed from access port plug area before proceeding. The torque on the access port plug should be 10 in-lbs.

Note: This testing is for piping system only.

The tank should be isolated and not subjected to the pressure used in testing the piping system. (See NFPA Code 30A for tank test recommendations.)

WARNING: Anytime an OPW 10 Series Emergency Valve is being tested or serviced, the power to the pumping system must be turned off.

After isolating tank, test piping as follows: Each OPW 10 PLUS Series Emergency Valve has a built in 3/8” test plug (See Figure 2) to permit testing of the piping system for leaks after installation. To use this valve in testing the piping, be certain pump is turned off.

There are two methods to test the valve (open or closed position). Follow the steps below for the chosen test method:

Pressure testing with valve poppet closed.

Closed Test Step 1. With pump off, shut off the 10P valve manually push the link (200518) away from the valve body. After moving link valve should be in the closed position as shown in Figure 4A.

Closed Test Step 2. After isolating tank, remove test plug, and attach test line. There is no need to break the line above or below the valve or to remove valve.

CAUTION: Do not use Teflon tape on threads. Coat test line threads with small amount of a UL classified gasoline-resistant pipe-joint sealing compound (non-hardening). Tighten until a complete seal is obtained. Additional tightening may cause the body to crack and allow product leakage at test or in service. (Torque specification is 9-11 foot-pounds)

NOTE: To prevent damage to the valve seat and disc, DO NOT apply more than 60-psi of pressure to the test line. See NFPA 30A for test details. A separate test is required for the tank.

Closed Test Step 3. After testing, remove test line and **reinstall test port plug** with UL classified gasoline-resistant pipe-joint sealing compound. To open the valve, rotate the hub counter clockwise with the link perpendicular. (See Figure 4B) Once the hub is fully rotated insert the pin into the hole on the link. Do NOT use pliers or a screwdriver. Use an 11/16 inch box-ended wrench.

NOTE: The test port plug must be reinstalled after testing. The test line must be removed.

Pressure testing with valve poppet open.

Open Test Step 1. To test valve in open position (See Figure 4B) plug top of valve with NPT plug (or BSP plug for "L" series).

NOTE: For double poppet style 10 valves a hollow plug must be used to ensure plug does not damage secondary poppet. (See Figure 5)

CAUTION: Do not use Teflon tape on threads. Coat test line threads with small amount of a UL classified gasoline-resistant pipe-joint sealing compound (non-hardening). Tighten until a complete seal is obtained. Additional tightening may cause the body to crack and allow product leakage at test or in service. (Torque specification is 9-11 foot-pounds)

CAUTION: Do not attempt to tighten plug into valve by wrenching above the shear section without a second wrench for support. Failure to support with second wrench could cause the shear section to fracture or break. Tighten on Wrench Surface "F".

Hold valve steady with one wrench on Wrench Surface "F" – if this wrench is turned the shear section may fracture or crack (See Figure 3). A second wrench is used to tighten the plug. Tighten threads until tight seal is obtained. Additional tightening may cause the body to crack and allow product leakage at test or in service. Max torque spec for plug in top is 135 foot-pounds.

The tank should be isolated and not subjected to the pressure used in testing the piping system. (See NFPA Code 30A for tank test recommendations.)

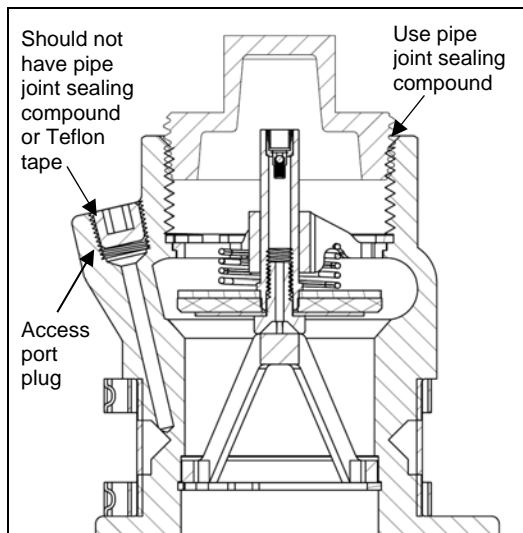

Figure 5 (Hollow plug shown)

Open Test Step 2. After isolating tank, remove test plug, and attach test line. There is no need to break the line below the valve or to remove valve.

NOTE: To prevent damage to the valve, DO NOT apply more than 60-psi of pressure to the test line. See NFPA 30A for test details. A separate test is required for the tank.

CAUTION: Do not use Teflon tape on threads. Coat test line threads with small amount of a UL classified gasoline-resistant pipe-joint sealing compound (non-hardening). Tighten until a complete seal is obtained. Additional tightening may cause the body to crack and allow product leakage at test or in service. (Torque specification is 9-11 foot-pounds)

NOTE: During testing ensure proper operation of SmartGuard. SmartGuard should not close the valve due to inflation. Small amounts of SmartGuard inflation may be evident due to thermal expansion.

Open Test Step 3. After testing, remove test plug in top of valve supporting it during removal with a second wrench as done during installation in Open Test Step 1. Remove test line and **reinstall test port plug** with UL classified gasoline-resistant pipe-joint sealing compound.

NOTE: The test port plug must be reinstalled after testing. The test line must be removed.

IN CASE OF DAMAGE OR FIRE

In the event the valve is activated due to fire, trauma or any other unintended situation, the valve body must be carefully examined. In the event any damage is suspected, the entire valve should be replaced. The valve must be fully tested prior to being returned to service.

NOTICE: A very strong blow or fire may cause the valve to be distorted. Any type of valve may distort after exposure to fire, shock, or impact and the poppet may not seat tightly. Only by replacing the top, or the entire valve, when necessary, can you be sure of getting a tight shut-off the next time an accident occurs.

In the event the SmartGuard activates the valve, do not attempt to open valve and engage link. Carefully inspect top as it may need to be replaced. If no cracks are present in the top, no fluid is in the SmartGuard area, and the SmartGuard has not been damaged it may be possible to engage link. Run SmartGuard integrity test from required maintenance section in these instructions ensuring proper operation before engaging link.

WARNING: Anytime an OPW 10 Series Emergency Valve is being tested or serviced, the power to the pumping system must be turned off.

HOW TO REPLACE TOP SHEAR SECTION

1. Shut off electrical power to dispenser and pump and lock the switch.
2. Shut off valve manually and drain system.
3. Remove pipe or fitting from top of valve. The body does NOT have to be removed.
4. Remove three (3) bolts and lift damaged top out of body. Remove old seal ring.
5. Ensure sealing surface is clean and free of debris. Also ensure surface is not damaged.
6. Install new seal ring and then the new top, (Top Assembly Replacement Kit). Replace three (3) bolts and tighten.
7. Replace pipe or fitting and test system for leaks.
8. Turn on electrical power to dispenser and pump.

CAUTION: Only use 10P replacement tops on 10P bodies. Do not use 10P parts on any other OPW shear valve. Doing so will void any and all warranties.

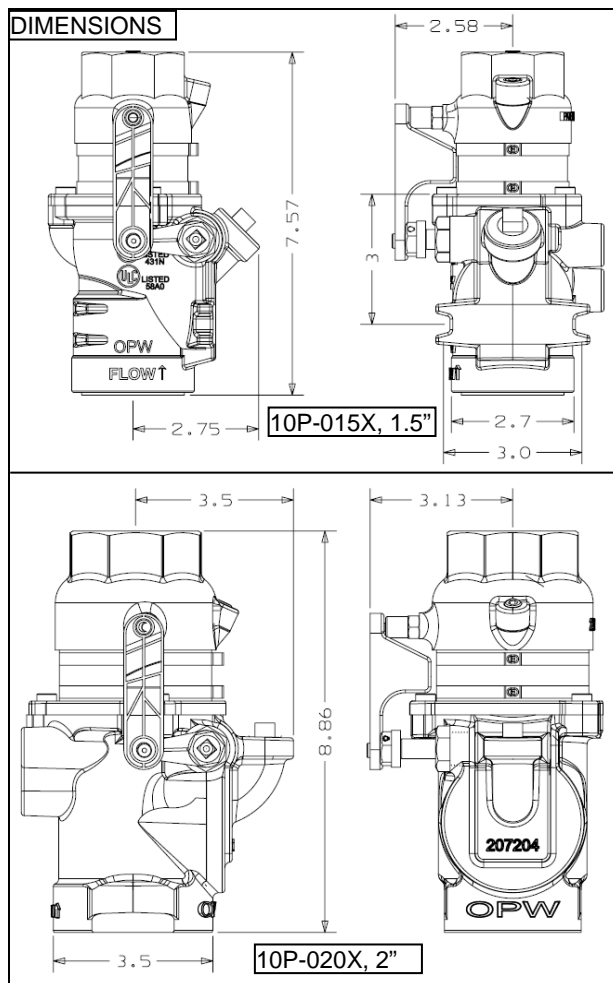

Figure 6



3250 US Highway 70 Business West * Smithfield, North Carolina
27577

1-800-422-2525 Domestically
1-513-870-3315 Internationally

www.opwglobal.com

Copyright, 2019 – OPW Retail Fueling, Smithfield, NC
Printed in U.S.A. p/n 201614 revision D – 10-31-19

IMPORTANT: Leave these installation instructions and maintenance procedures with the station operator.

Notice: OPW products must be used in compliance with applicable federal, state, and local laws and regulations. Product selection should be based on physical specifications and limitations and compatibility with the environment and material to be handled. All illustrations and specifications in this literature are based on the latest production information available at the time of publication. Prices, materials, and specification are subject to change at any time, and models may be discontinued at any time, in either case, without notice or obligation.

Product Warranty

OPW warrants that products sold by it are free from defects in materials and workmanship for a period of one year from the date of shipment by OPW. As the exclusive remedy under this limited warranty, OPW, will at its sole discretion, repair, replace, or issue credit for future orders for any product that may prove defective within the one-year period. This warranty shall not apply to any product that has been altered in any way, which has been repaired by any party other than a service representative authorized by OPW, or when failure is due to misuse, conditions of use, or improper installation or maintenance. OPW shall in no instance have any liability whatsoever for special, incidental or consequential damages to any party and shall have no liability for the cost of labor, freight, excavation, clean up, downtime, removal, reinstallation, loss of profit, or any other cost or charges in excess of the amount of the original invoice for the products.

THIS WARRANTY IS IN LIEU OF ALL OTHER WARRANTIES, EXPRESS OR IMPLIED, AND SPECIFICALLY THE WARRANTIES OF MERCHANTABILITY AND FITNESS FOR A PARTICULAR PURPOSE. THERE ARE NO WARRANTIES, WHICH EXTEND BEYOND THE DESCRIPTION OF THE FACE HEREOF.