

# Model A-183-SS

Check Valve

April 3, 2017

(Rev. 2)

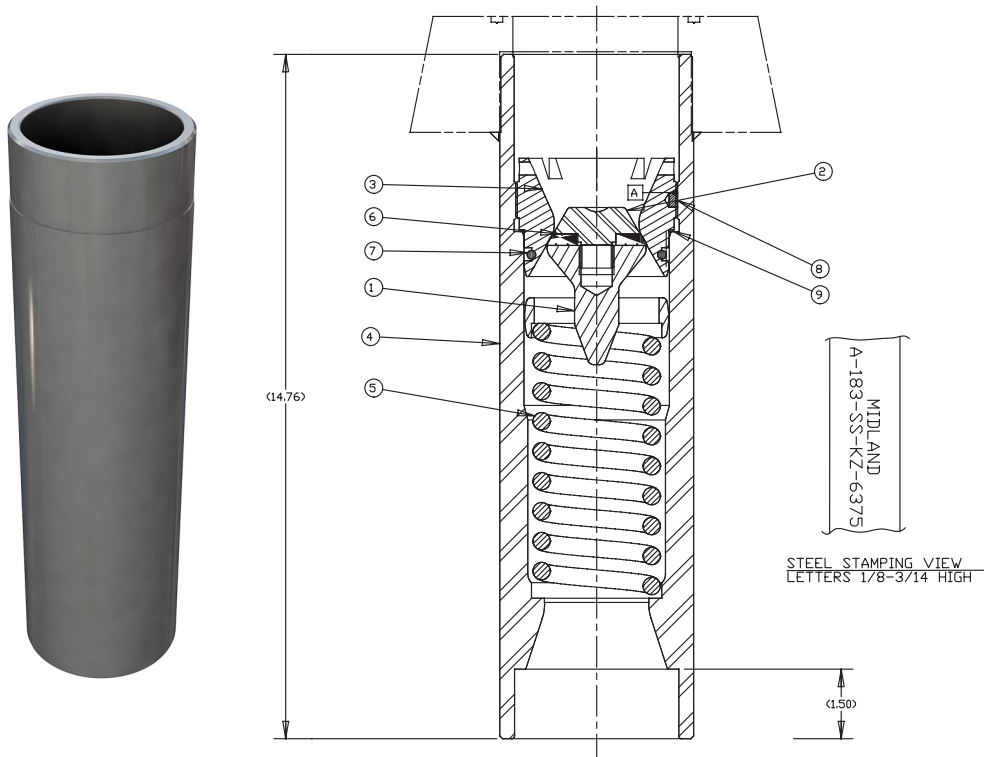

ITEM	QTY	PART NAME	MATERIAL	PART NO.
1	1	GUIDE	304 STAINLESS	183-1-SS
2	1	RETAINER	NITRONIC 60	183-2-N60
3	1	SEAT	NITRONIC 60	183-3-N60
4	1	BODY, MACHINED	304L STAINLESS	183-4-SS
5	1	SPRING	304 STAINLESS	183-5-SS
6	1	SEAT SEAL	PTFE	183-6-TF
7	1	O-RING (-334)	KALREZ 6375	183-7-KZ-6375
8	2	INSERT	PTFE	180-8-TF
9	1	GASKET	PTFE	183-9-TF

**NOTES:**

- 1 USE ASSEMBLY TOOL TO T-A-183 TO INSTALL/REMOVE 183-1-SS GUIDE
- 2 AFTER ASSEMBLY SEALS TO BE TESTED @ 500 PSI FOR 2 MIN
- 3 CAUTION: SPRING LOADED ASSEMBLY
- 4 AAR APPROVAL # E102011

