

A-144-P Check Valve

April 29, 2015



TECHNICAL SPECIFICATIONS

- Vapor Valve with Surge Shield
- Cylinder Style Float
- Materials: Mall Iron and Steel
- Mount Type: Weld
- Mount Size: 2 7/8" Diameter
- AAR Approval #: E122004



A-144-P
Check Valve
 April 29, 2015

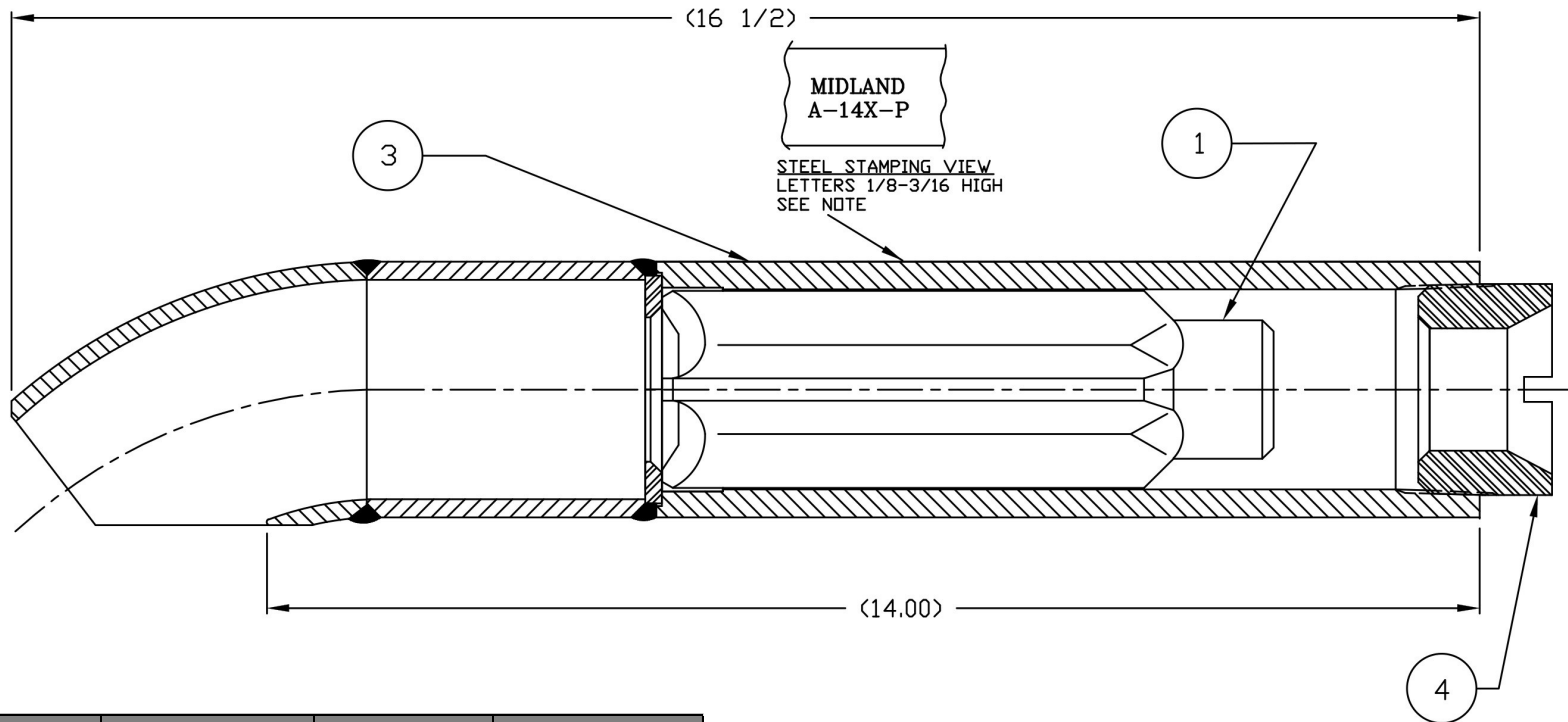

ITEM	QTY	PART NAME	MATERIAL	PART NUMBER
1	1	FLOAT	MALL IRON	144-1-MI
3	1	BODY ASSEMBLY	STEEL	144-31-CS
4	1	PLUG*	STEEL	134-5-CS
* NOTE: USE WRENCH T-312-CS TO INSTALL OR REMOVE PLUG				

