

Model A-120 Series

Check Valve

Oct. 20, 2018

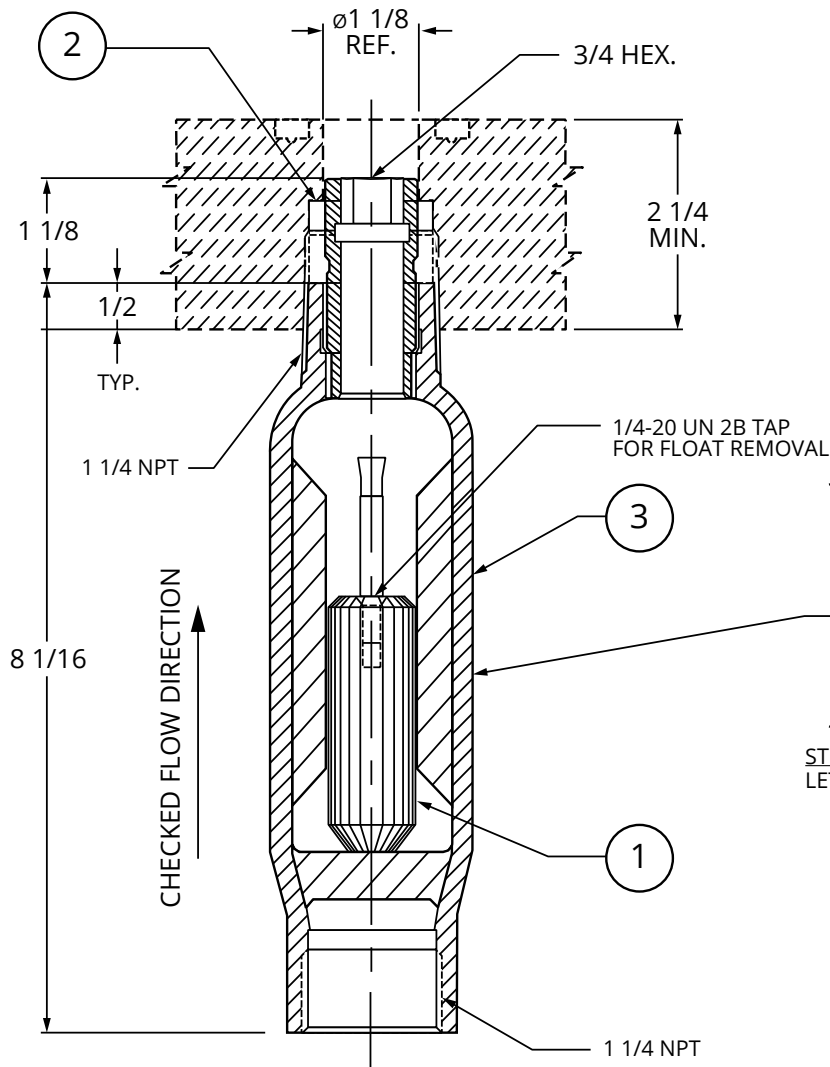

Item	QTY	Part Name	A-120-CS		A-120-SS		A-120-ML	
			Material	Part No.	Material	Part No.	Material	Part No.
1	1	FLOAT	STEEL	120-1-CS	STAINLESS STEEL	120-1-SS	MONEL	120-1-ML
2	1	SEAT	STEEL	120-2-CS	STAINLESS STEEL	120-2-SS	MONEL	120-2-ML
3	1	BODY	STEEL	120-3-CS	STAINLESS STEEL	120-3-SS	MONEL	120-3-ML

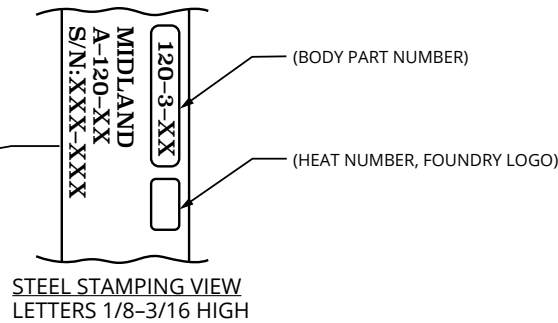

NOTES:

- MAXIMUM FLOW RATE IS 38,000 LBS OF CHLORINE PER HOUR
- AAR APPROVAL NO. E092011