

Model A-207
Vacuum Relief Valve
August 13, 2015

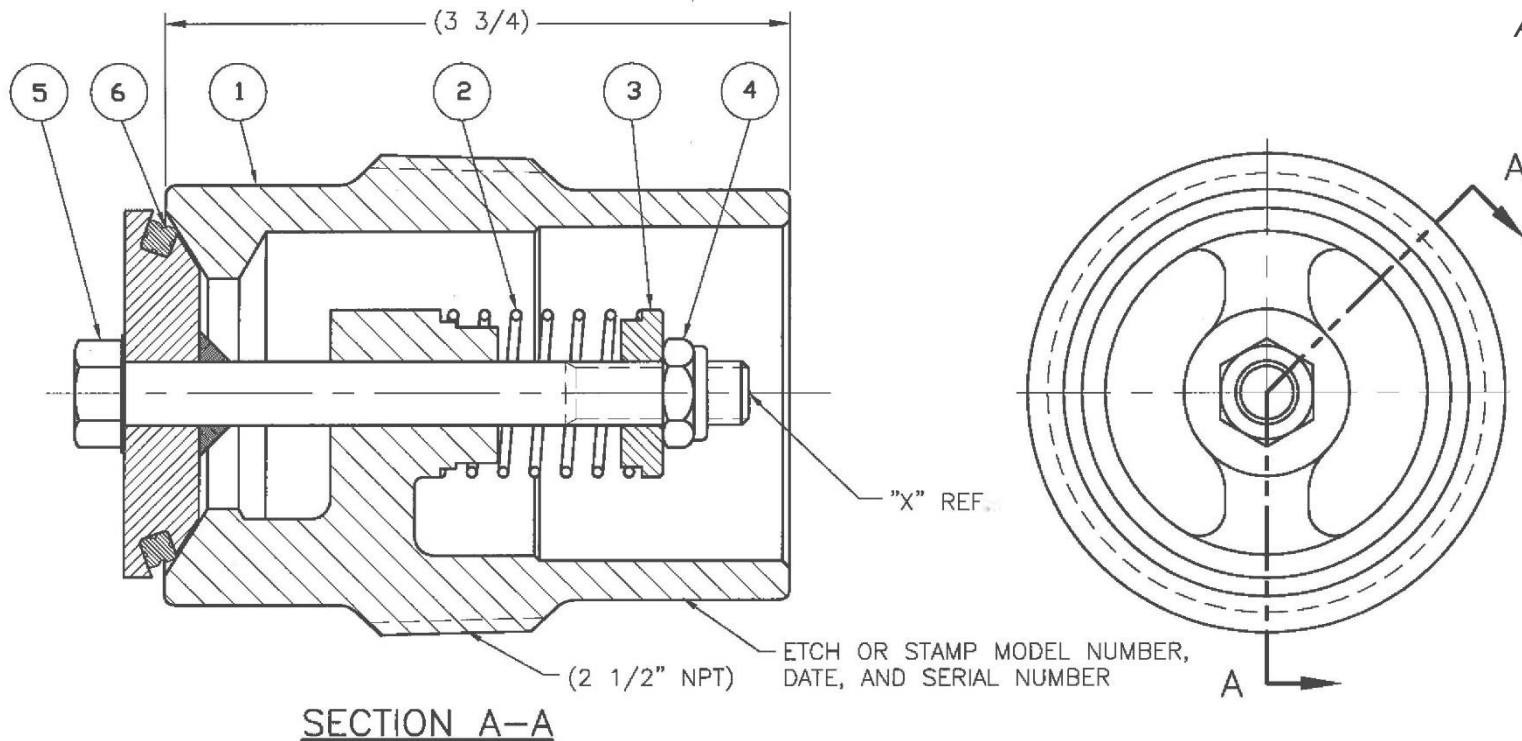

Item	QTY	Part Name	Material	Part No.
1	1	BODY	STAINLESS STEEL	207-1-SS
2	1	SPRING	STAINLESS STEEL	SEE TABLE
3	1	SPRING SEAT	STAINLESS STEEL	207-3-SS
4	1	LOCK NUT	STAINLESS STEEL	207-41-SS
5	1	STEM	STAINLESS STEEL	207-52-MO
6	1	PRESSURE SEAL	WHITE NEOPRENE (1)	205-6-WNE

Vacuum Settings	
Vacuum Setting (PSI)	Spring Part Number
0.75	207-2-MO
3	207-21-MO

NOTES:

- ALTERNATE MATERIAL AVAILABLE
- AAR APPROVAL # E092015

