

A-430-T, A-432-T, A-434-T

ITEM	QTY	PART NAME	A-430-T		A-432-T		A-434-T	
			MATERIAL	PART NO.	MATERIAL	PART NO.	MATERIAL	PART NO.
1	1	TOP	MALL. IRON	425-1-MI	MALL. IRON	425-1-MI	STAINLESS	429-1-SS
2	1	BASE, FLANGED	STEEL	435-2-CS	STAINLESS	435-2-SS	STAINLESS	435-2-SS
3	1	DISC (2)	STAINLESS	425-3-SS	STAINLESS	425-3-SS	STAINLESS	425-3-SS
4	1	RETAINER	DUCTILE IRON	425-4-DI	DUCTILE IRON	425-4-DI	STAINLESS	429-4-SS
5	1	SWING PIN ASM	SS/STEEL	425-5-XS	SS/STEEL	425-5-XS	STAINLESS	429-5-SS
6	4	NUT	STEEL	425-6-CS	STEEL (1)	425-6-CS	STAINLESS	429-6-SS
7	3	STUD	STEEL	425-7-CS	STEEL (1)	425-7-CS	NITRONIC 60	429-71-N6C
8	1	HINGE PIN	STEEL	425-8-CS	STEEL (1)	425-8-CS	STAINLESS	429-8-SS
9	1	EYE BOLT PIN	STEEL	425-9-CS	STEEL	425-9-CS	STAINLESS	429-9-SS
10	1	CHAIN	STEEL	24-3-CS	STEEL	24-3-CS	STEEL (1)	24-3-CS
11	4	COTTER PIN	STAINLESS	429-72-SS	STAINLESS	429-72-SS	STAINLESS	429-72-SS
12	1	EYE BOLT	STEEL	425-12-CS	STEEL (1)	425-12-CS	STAINLESS	429-12-SS
13	1	SEAL (2)	SS/LEAD	22-72-PB	SS/LEAD	22-72-PB	SS/LEAD	22-72-PB
14	1	TANK CHAIN (2)	STEEL	425-14-CS	STEEL (1)	425-14-CS	STEEL (1)	425-14-CS
15	2	SCREW/RIVET	STAINLESS	763-11-SS	STAINLESS	763-11-SS	STAINLESS	424-15-SS
16	1	NAMEPLATE	STAINLESS	424-16-SS	STAINLESS	424-16-SS	STAINLESS	424-16-SS

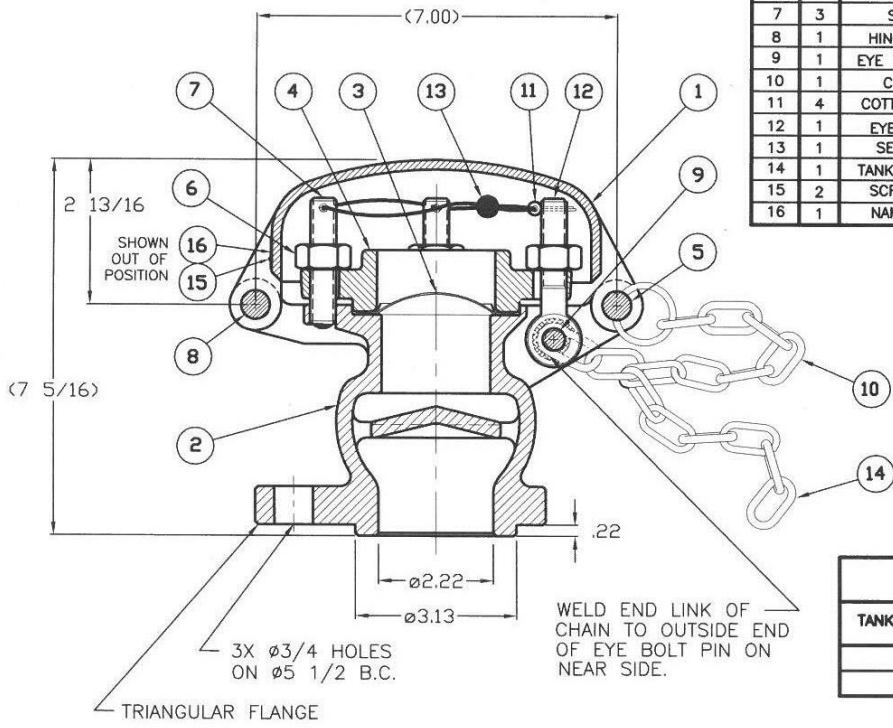

- NOTES:**
- (1) ALTERNATE MATERIALS AVAILABLE.
 - (2) NOT FURNISHED UNLESS REQUESTED.
 - (3) AAR # PRD102008

FLOW CAPACITY WITHOUT RUPTURE DISC INSTALLED		FLOW CAPACITY WITH STAINLESS STEEL STANDARD TANK CAR RUPTURE DISC INSTALLED	
TANK PRESSURE (PSIG)	FLOW RATE (SPCFM)	TANK PRESSURE (PSIG)	FLOW RATE (SPCFM)
85	3382	85	3292
181	6665	181	6478