

# A-425-F

ITEM	QTY	PART NAME	MATERIAL	PART NUMBER
1	1	TOP	MALL. IRON	425-1-MI
2	1	BASE, FLANGED	STEEL	425-22-CS
3	1	DISC (2)	STAINLESS STEEL	425-3-SS
4	1	RETAINER	DUCTILE IRON	425-4-DI
5	1	SWING PIN ASSEMBLY	SS/STEEL	425-5-XS
6	4	NUT	STEEL	425-6-CS
7	3	STUD	STEEL	425-7-CS
8	1	HINGE PIN	STEEL	425-8-CS
9	1	EYE BOLT PIN	STEEL	425-9-CS
10	1	CHAIN	STEEL (1)	24-3-CS
11	4	COTTER PIN	STAINLESS STEEL	545-28-SS
12	1	EYE BOLT	STEEL	425-12-CS
13	1	SEAL (2)	SS/LEAD	22-72-PB
14	4	TANK CHAIN (2)	STEEL (1)	425-14-CS
15	1	NAMEPLATE	STAINLESS STEEL	424-16-SS
16	2	DRIVE SCREW	STAINLESS STEEL	763-11-SS

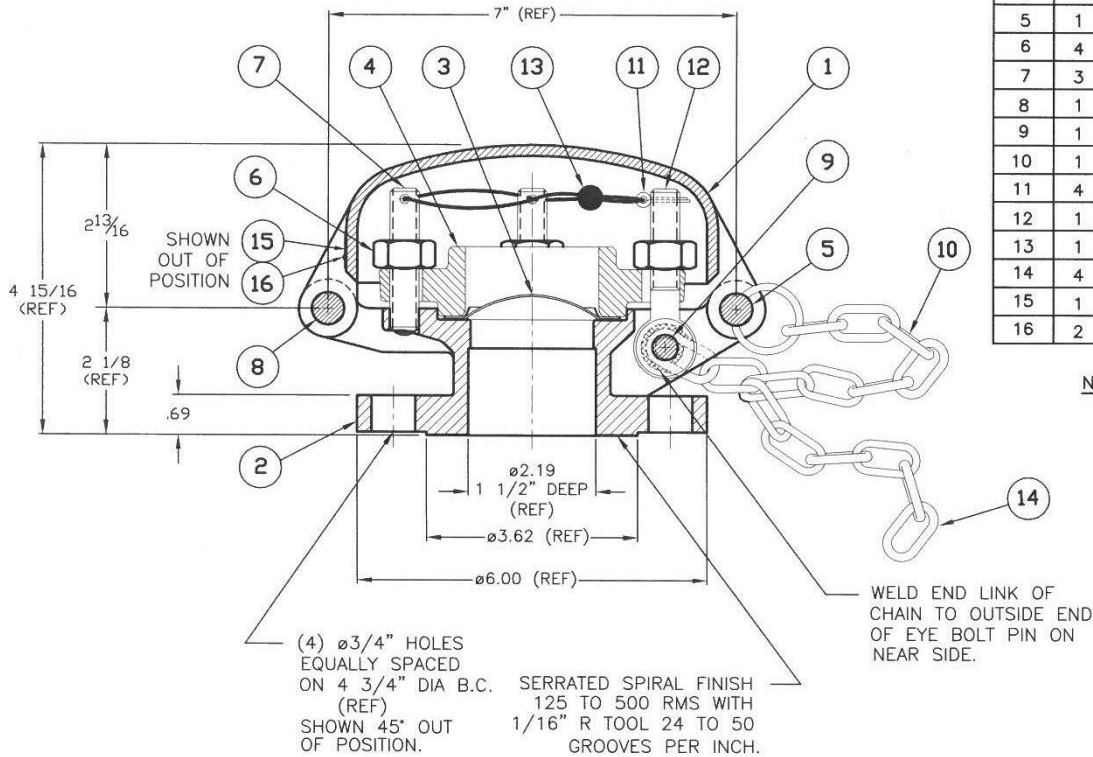

**NOTES:**

- (1) ALTERNATE MATERIALS AVAILABLE.
- (2) NOT FURNISHED UNLESS REQUESTED.